

ELATION®



Fuze PFX

Photometric &
Chromaticity Test Reports

CONTENTS

Testing Procedures	4
Photometric Output Reports	5
Zoom Wide.....	5
Zoom 50%.....	7
Zoom Narrow	9
Zoom 50%-CTO	11
Zoom 50%-CRI 80	13
Zoom 50%-CRI 90	15
Zoom 50%-CRI 80-CTO	17
Zoom 50%-CRI 90-CTO	19
Zoom 50%- Low Fan Mode	21
Zoom 50%- Studio Fan Mode	23
Zoom 50%- Mute Fan Mode	25
Color Quality Reports	27
Full Output.....	27
CTO	29
CRI 80	31
CRI 90	33
CRI 80 CTO	35
CRI 90 CTO	37
Color Reports	39
Cyan.....	39
Magenta.....	40
Yellow.....	41



Elation Professional USA | 6122 S. Eastern Ave. | Los Angeles, CA. 90040
323-582-3322 | 323-832-9142 fax | www.elationlighting.com | info@elationlighting.com

Elation Professional B.V. | Junostraat 2 | 6468 EW Kerkrade, The Netherlands
+31 45 546 85 66 | +31 45 546 85 96 fax | www.elationlighting.eu | info@elationlighting.eu

Elation Professional Mexico | AV Santa Ana 30 | Parque Industrial Lerma, Lerma, Mexico 52000
+52 (728) 282-7070

Testing Process

Total Lumen Measurements

Lumens are measured using a Viso Systems Lab Spion. As a goniophotometer, the Viso calculates the field lumens of the fixture by taking multiple measurements across the light beam.

Many lumens figures provided for entertainment lighting fixtures are only 2π sphere values, some even emphasize the LED engine lumens. All Elation product photometric data is the actual light output from the fixture lens, never a theoretical value based on calculation or using the source lumens as the fixtures output. We advise to always compare total fixture lumens acquired with identical measurement systems when comparing lighting fixtures.

Test Lab Equipment and Process

Elation operates an optical testing laboratory at its Los Angeles, CA headquarters to provide accurate photometric data for its lighting products. The testing lab is both light and climate- controlled and contains a variety of precise lighting measurement systems. Fixtures are analyzed with the sophisticated [Viso Systems Lab Spion](#) equipment, which measures all light and color parameters by panning the light beam at a precise speed and from different angles through a calibrated, laser aligned light and color sensor. Test data is collected and summarized by the Viso Light Inspector software. This type of measurement system is referred to as a Goniophotometer.

The Viso software calculates all relevant types of measurements, from beam angles, candela to center light intensity at a variety of distances to the latest color quality measurements like TM30 or CQS as well as accurate color temperature. This wealth of data is then processed by an Elation specific template which is included in the photometric test report for various fixture conditions such as zoom angles and color correction filters.

The Viso software also creates IES (Illuminating Engineering Society) files for each test report. IES is an industry standard file format created for the easy electronic transfer of photometric test data, which is widely used by lighting manufacturers for photometric data distribution.

Additionally, fixtures are periodically rechecked for accuracy using various hand-held light meters including one or more of the devices listed below. This is done to ensure the test data contained in this report is as accurate as possible.

[Asenstek Lighting Passport](#) | [Konica Minolta T-10](#) | [Sekonic C800U](#)

Key Measurements

Output

Total Lumen Output: 14745 lm

Peak Intensity: 24557 cd

Beam

Beam Angle (50%): 50.1°

Field Angle (10%): 55°

Cutoff Angle (2.5%): 56.3°

Color

Color Temperature: 6599 K

CRI: 71.6

TLCI: 49

TM30 R_F: 72.4

TM30 R_g: 92.9

Power Details

Efficacy: 28 Lumen/Watt

Power: 525 W

Supply Voltage: 118 V

Current: 4.45 A

Beam Details

Distance	3 m	5 m	10 m	15 m	20 m
Beam Width	2.8 m	4.7 m	9.4 m	14 m	18.7 m

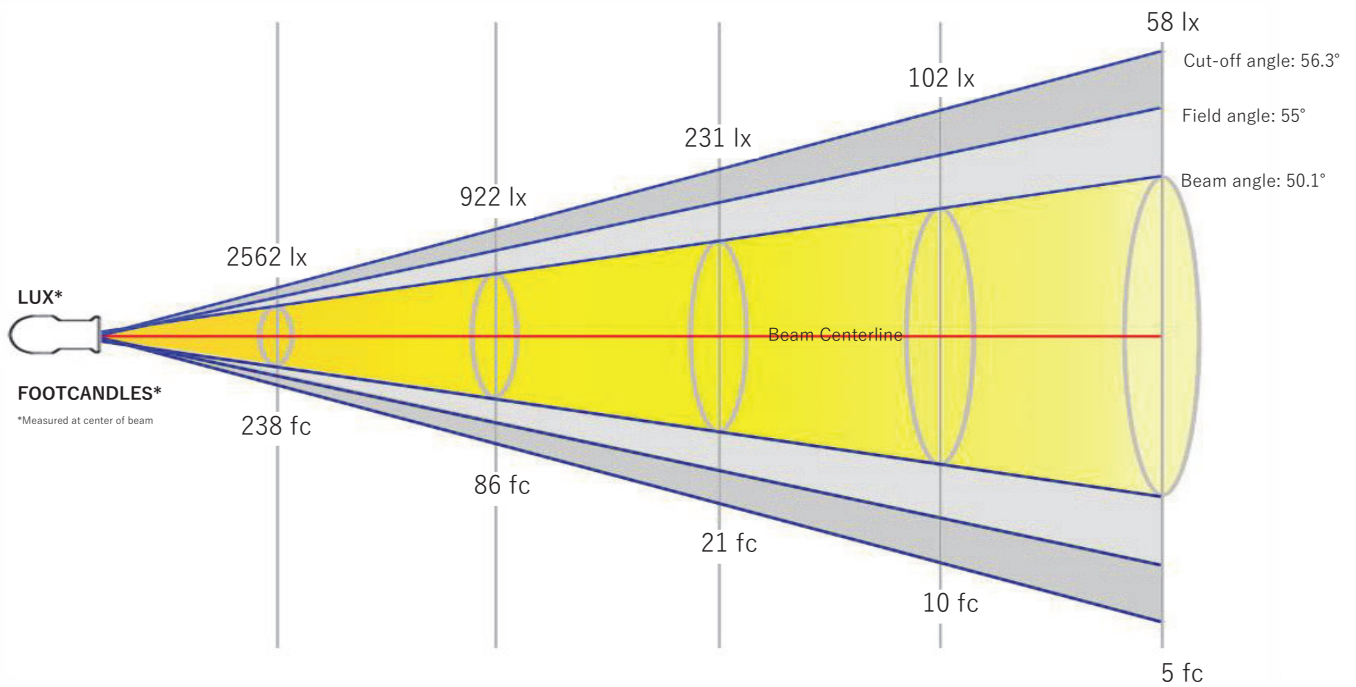

Distance	9.8 ft	16.4 ft	32.8 ft	49.2 ft	65.6 ft
Beam Width	9.2 ft	15.3 ft	30.7 ft	46 ft	61.4 ft

Beam Intensities from 1-20m

M	1	2	3	4	5	6	7	8	9	10	11	12	13	14	15	16	17	18	19	20
LX	23054	5764	2562	1441	922	640	470	360	285	231	191	160	136	118	102	90	80	71	64	58
FT	3.3	6.6	9.8	13.1	16.4	19.7	23	26.2	29.5	32.8	36.1	39.4	42.7	45.9	49.2	52.5	55.8	59.1	62.3	65.6
FC	2141.8	535.5	238	133.9	85.7	59.5	43.7	33.5	26.4	21.4	17.7	14.9	12.7	10.9	9.5	8.4	7.4	6.6	5.9	5.4

Angular Distribution

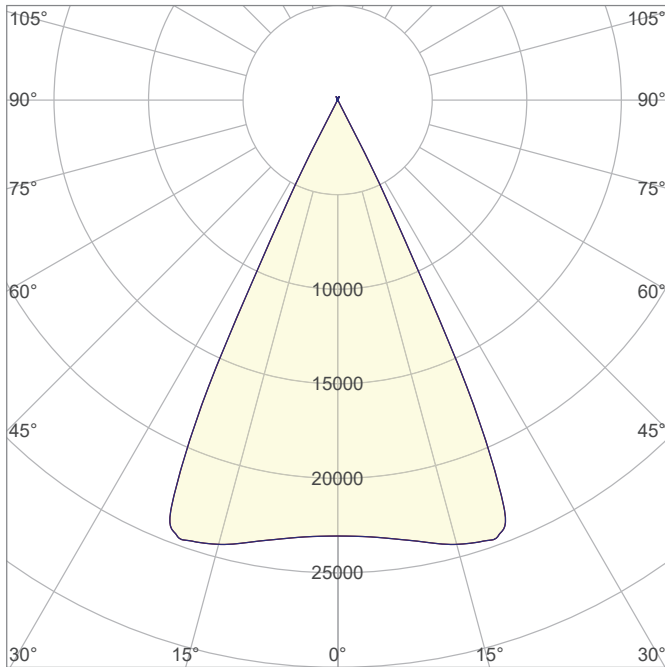

Beam Angle - 50%
50.1°
Field Angle - 10%
55°
Cutoff Angle - 2.5%
56.3°

ISO Diagrams

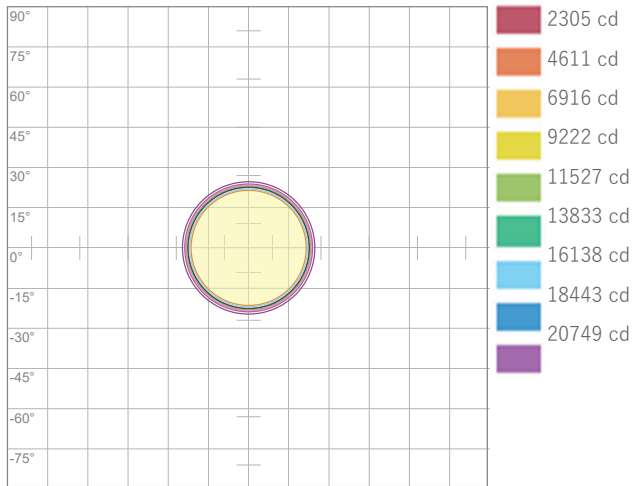

ISO Candela Diagram

Conditions:
Number of c-planes: 8
Candela at center: 23054 cd

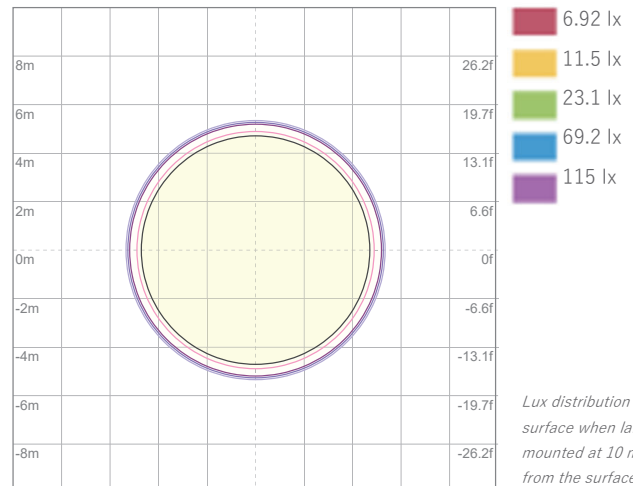

ISO LUX Diagram

Conditions:
Number of c-planes: 8
LUX at center: 231 lx

Lux distribution on a surface when lamp is mounted at 10 meters from the surface.

Linear Distribution

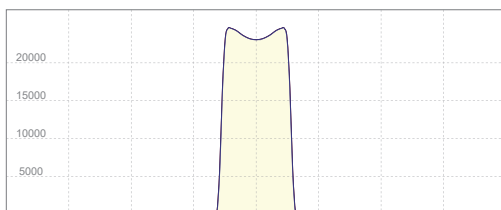

Peak Candela
24557 cd

Calculate Center Beam Intensities

$$\text{lux} = 24557 / \text{distance(m)}^2$$

$$\text{fc} = 24557 / \text{distance(ft)}^2$$

Key Measurements

Output

Total Lumen Output: 13751 lm
Peak Intensity: 220997 cd

Beam

Beam Angle (50%): 16°
Field Angle (10%): 18.1°
Cutoff Angle (2.5%): 19°

Color

Color Temperature: 6489 K
CRI: 71.8
TLCI: 49
TM30 R_F: 72.5
TM30 R_g: 93.4

Power Details

Efficacy: 26 Lumen/Watt
Power: 521 W
Supply Voltage: 116 V
Current: 4.49 A

Beam Details

Distance	3 m	5 m	10 m	15 m	20 m
Beam Width	0.8 m	1.4 m	2.8 m	4.2 m	5.6 m

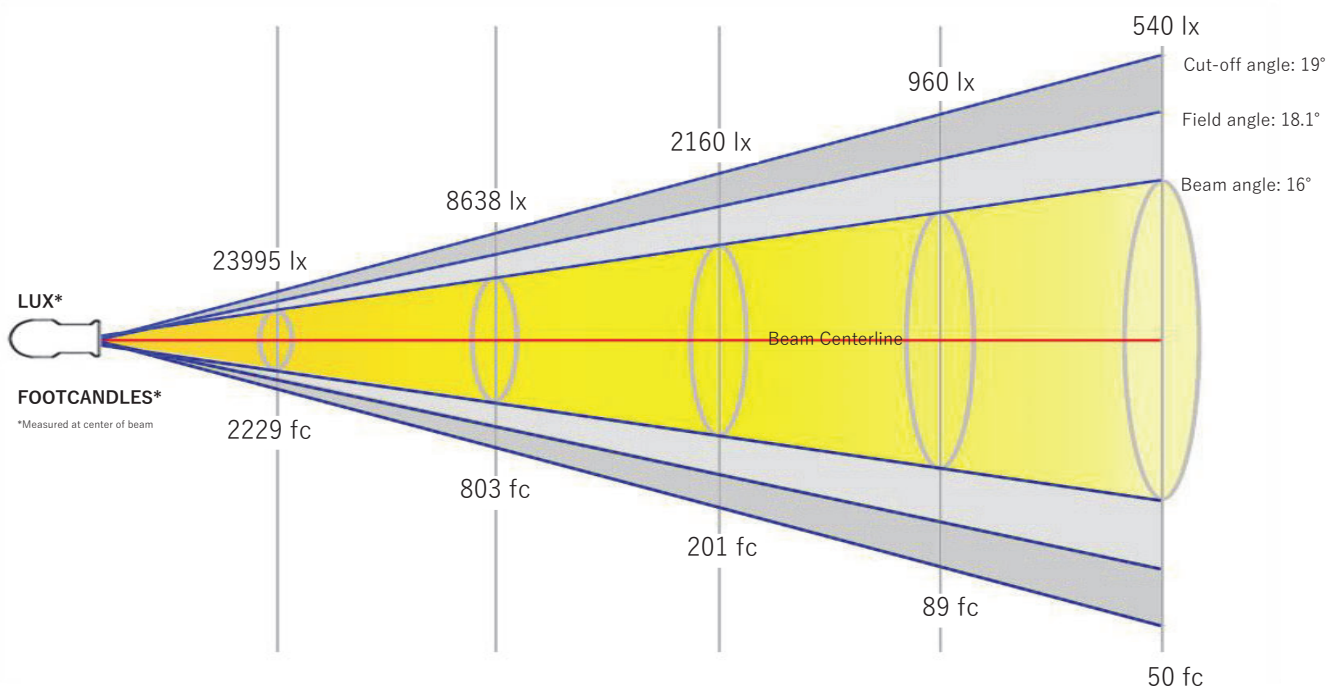

Distance	9.8 ft	16.4 ft	32.8 ft	49.2 ft	65.6 ft
Beam Width	2.8 ft	4.6 ft	9.2 ft	13.8 ft	18.4 ft

Beam Intensities from 1-20m

M	1	2	3	4	5	6	7	8	9	10	11	12	13	14	15	16	17	18	19	20
LX	215959	53990	23995	13497	8638	5999	4407	3374	2666	2160	1785	1500	1278	1102	960	844	747	667	598	540
FT	3.3	6.6	9.8	13.1	16.4	19.7	23	26.2	29.5	32.8	36.1	39.4	42.7	45.9	49.2	52.5	55.8	59.1	62.3	65.6
FC	20063.2	5015.8	2229.2	1254	802.5	557.3	409.5	313.5	247.7	200.6	165.8	139.3	118.7	102.4	89.2	78.4	69.4	61.9	55.6	50.2

Angular Distribution

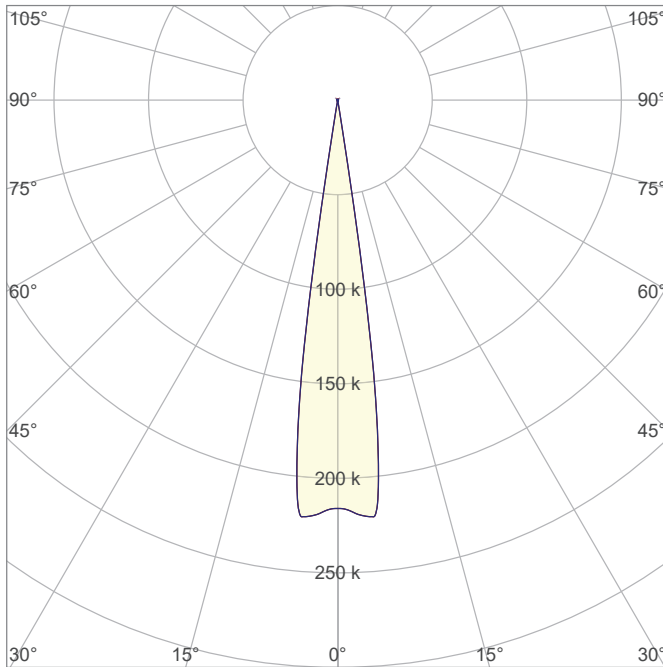

Beam Angle - 50%
16°
Field Angle - 10%
18.1°
Cutoff Angle - 2.5%
19°

ISO Diagrams

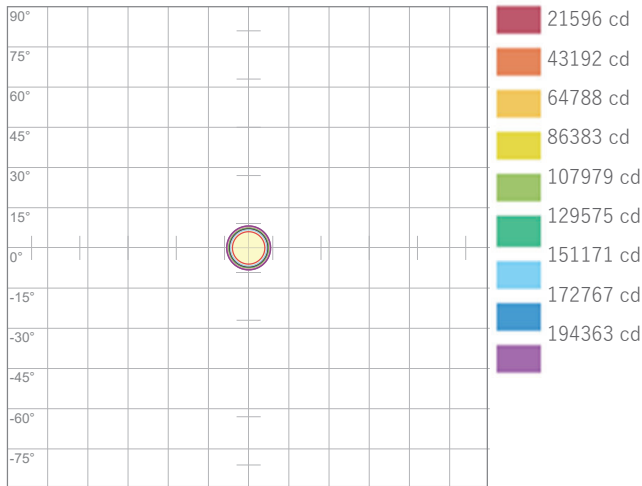

ISO Candela Diagram

Conditions:
Number of c-planes: 8
Candela at center: 215959 cd

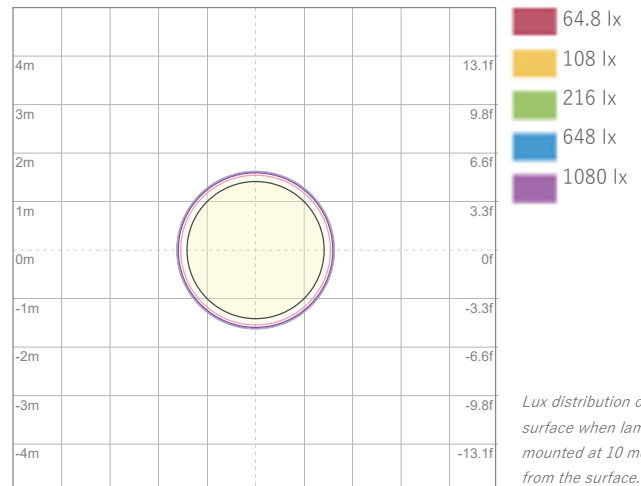

ISO LUX Diagram

Conditions:
Number of c-planes: 8
LUX at center: 2160 lx

Lux distribution on a surface when lamp is mounted at 10 meters from the surface.

Linear Distribution

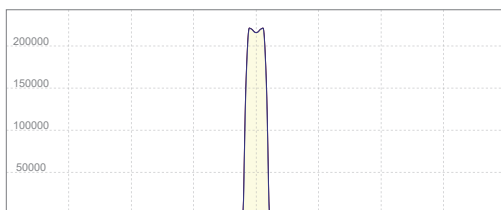

Peak Candela
220997 cd

Calculate Center Beam Intensities

$$\text{lux} = 220997 / \text{distance(m)}^2$$

$$\text{fc} = 220997 / \text{distance(ft)}^2$$

Key Measurements

Output

Total Lumen Output: 3875 lm
Peak Intensity: 2643515 cd

Beam

Beam Angle (50%): 2.4°
Field Angle (10%): 3.3°
Cutoff Angle (2.5%): 3.6°

Color

Color Temperature: 6371 K
CRI: 71.9
TLCI: 49
TM30 R_F: 72.6
TM30 R_g: 93.6

Power Details

Efficacy: 7 Lumen/Watt
Power: 520 W
Supply Voltage: 116 V
Current: 4.48 A

Beam Details

Distance	3 m	5 m	10 m	15 m	20 m
Beam Width	0.1 m	0.2 m	0.4 m	0.6 m	0.8 m

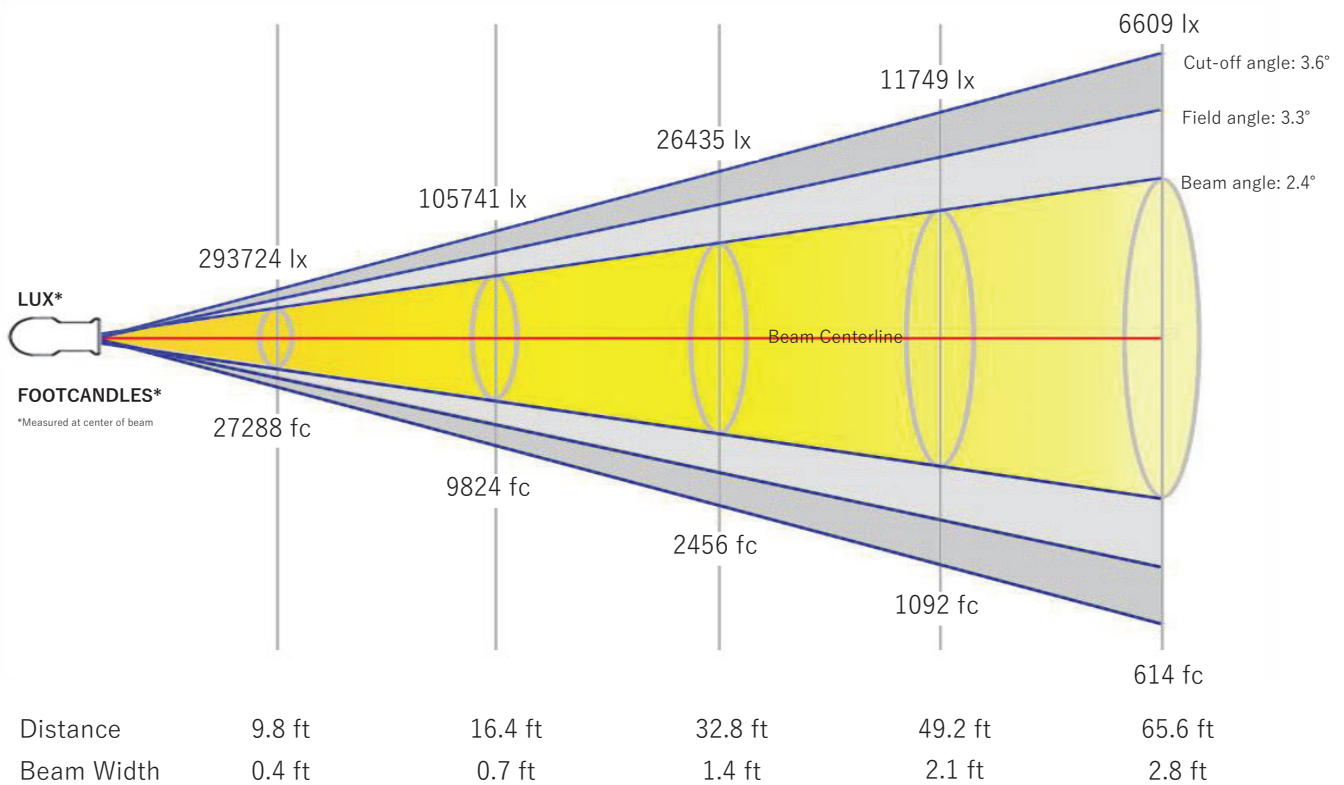

Beam Intensities from 1-20m

M	1	2	3	4	5	6	7	8	9	10	11	12	13	14	15	16	17	18	19	20
LX	2643515	660879	293724	165220	105741	73431	53949	41305	32636	26435	21847	18358	15642	13487	11749	10326	9147	8159	7323	6609
FT	3.3	6.6	9.8	13.1	16.4	19.7	23	26.2	29.5	32.8	36.1	39.4	42.7	45.9	49.2	52.5	55.8	59.1	62.3	65.6
FC	245590.6	61397.6	27287.8	15349.4	9823.6	6822	5012.1	3837.4	3032	2455.9	2029.7	1705.5	1453.2	1253	1091.5	959.3	849.8	758	680.3	614

Angular Distribution

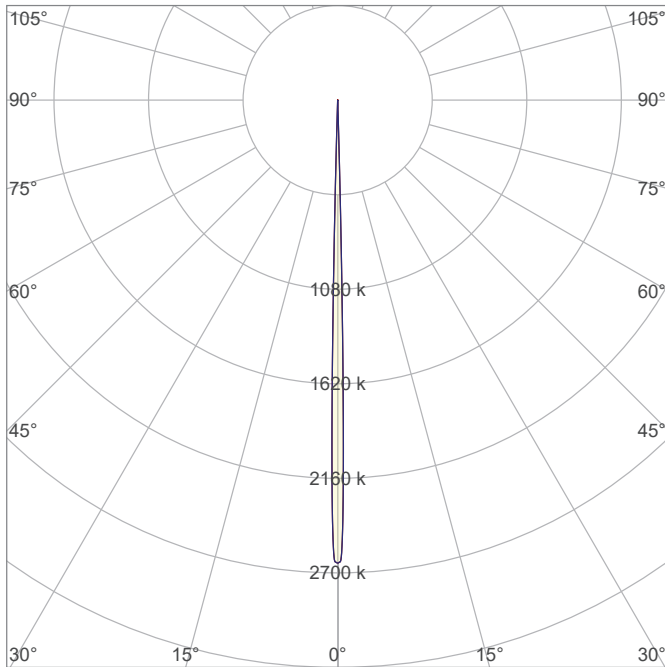

Beam Angle - 50%
2.4°
Field Angle - 10%
3.3°
Cutoff Angle - 2.5%
3.6°

ISO Diagrams

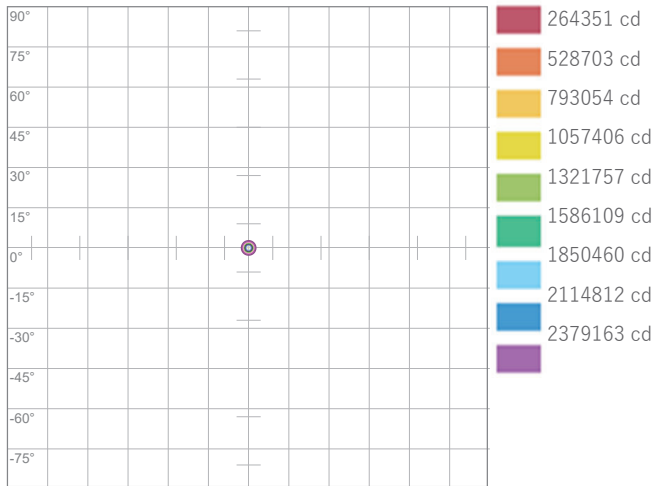

ISO Candela Diagram

Conditions:
Number of c-planes: 8
Candela at center: 2643515 cd

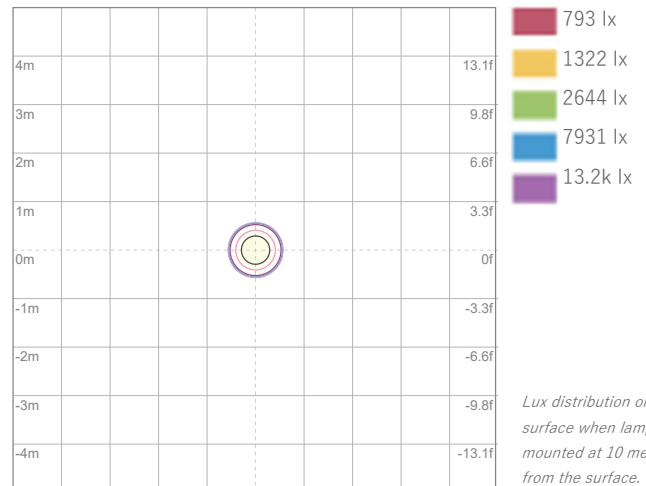

ISO LUX Diagram

Conditions:
Number of c-planes: 8
LUX at center: 26.4k lx

Lux distribution on a surface when lamp is mounted at 10 meters from the surface.

Linear Distribution



Peak Candela
2643515 cd

Calculate Center Beam Intensities

$$\text{lux} = 2643515 / \text{distance(m)}^2$$

$$\text{fc} = 2643515 / \text{distance(ft)}^2$$

Key Measurements

Output

Total Lumen Output: 3167 lm
Peak Intensity: 50433 cd

Beam

Beam Angle (50%): 15.9°
Field Angle (10%): 18.2°
Cutoff Angle (2.5%): 18.9°

Color

Color Temperature: 2356 K
CRI: 91.1
TLCI: 75
TM30 R_F: 89.3
TM30 R_g: 100.9

Power Details

Efficacy: 6 Lumen/Watt
Power: 533 W
Supply Voltage: 116 V
Current: 4.59 A

Beam Details

Distance	20 m	40 m	60 m	80 m	100 m
Beam Width	5.6 m	11.2 m	16.7 m	22.3 m	27.9 m

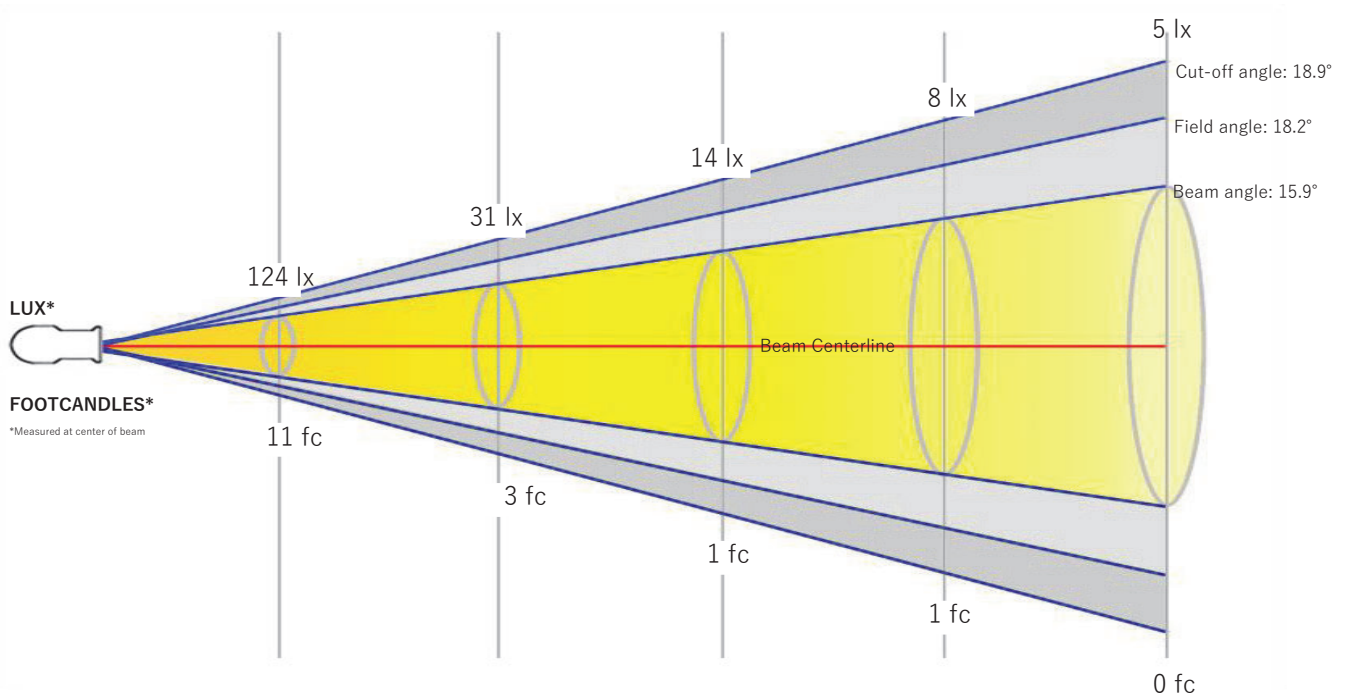

Distance	65.6 ft	131.2 ft	196.9 ft	262.5 ft	328.1 ft
Beam Width	18.3 ft	36.6 ft	55 ft	73.3 ft	91.6 ft

Beam Intensities from 1-100m

M	5	10	15	20	25	30	35	40	45	50	55	60	65	70	75	80	85	90	95	100
LX	1980	495	220	124	79	55	40	31	24	20	16	14	12	10	9	8	7	6	5	5
FT	16,4	32,8	49,2	65,6	82,0	98,4	114,8	131,2	147,6	164,0	180,4	196,9	213,3	229,7	246,1	262,5	278,9	295,3	311,7	328,1
FC	184	46	20	11	7	5	4	3	2	2	2	1	1	1	1	1	1	1	1	0

Angular Distribution

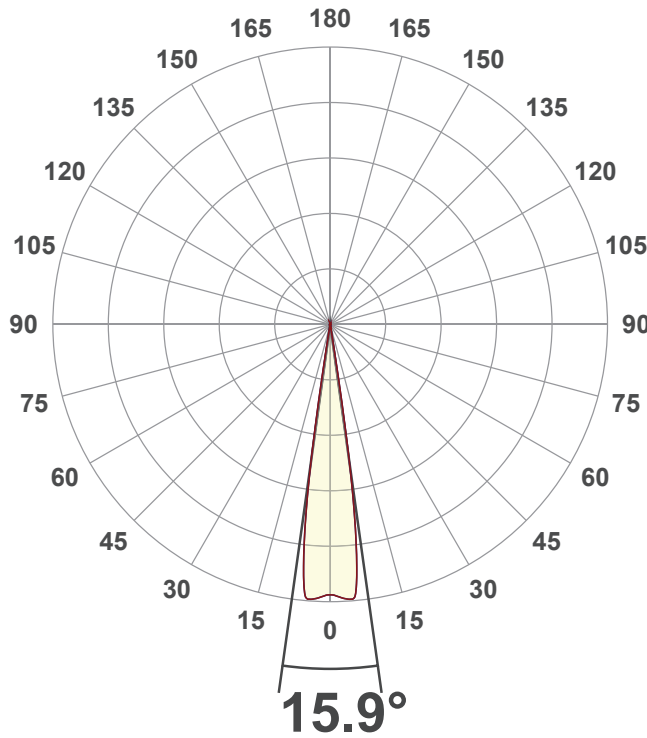

Beam Angle - 50%
15.9°
Field Angle - 10%
18.2°
Cutoff Angle - 2.5%
18.9°

ISO Diagrams

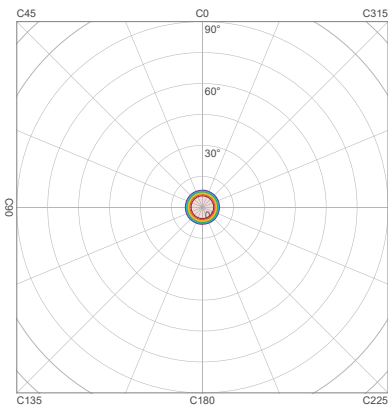

90 %	45374.5 cd
80 %	40332.9 cd
70 %	35291.3 cd
60 %	30249.7 cd
50 %	25208.1 cd
40 %	20166.4 cd
30 %	15124.8 cd
20 %	10083.2 cd
10 %	5041.6 cd

Peak intensity: 50416.1 cd
Number of c-planes: 8

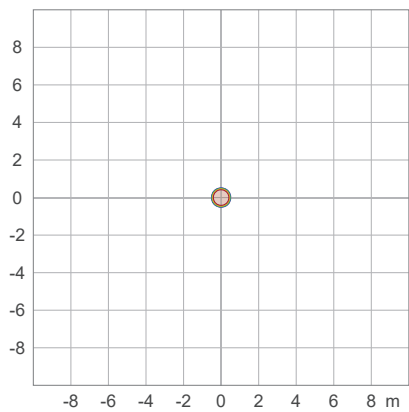

50.0 %	2780 lx
30.0 %	1668 lx
10.0 %	556 lx
5.0 %	278 lx
3.0 %	167 lx

Peak illuminance: 5561 lx
Mounting height: 3 m
Number of c-planes: 8

ISO Candela Diagram

ISO LUX Diagram

Conditions:

Number of c-planes: 8
Candela at center: 49500 cd

Conditions:

Number of c-planes: 8
LUX at center: 495 lx

Linear Distribution

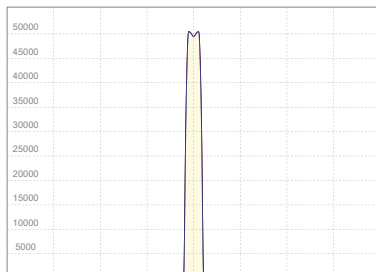

Peak Candela
50433 cd

Calculate Center Beam Intensities

$$\text{lux} = 50433 / \text{distance(m)}^2$$

$$\text{fc} = 50433 / \text{distance(ft)}^2$$

Key Measurements

Output

Total Lumen Output: 9892 lm
Peak Intensity: 160700 cd

Beam

Beam Angle (50%): 15.9°
Field Angle (10%): 18°
Cutoff Angle (2.5%): 18.5°

Color

Color Temperature: 6593 K
CRI: 88.7
TLCI: 79
TM30 R_F: 84.6
TM30 R_g: 100.8

Power Details

Efficacy: 19 Lumen/Watt
Power: 520 W
Supply Voltage: 115 V
Current: 4.52 A

Beam Details

Distance	3 m	5 m	10 m	15 m	20 m
Beam Width	0.8 m	1.4 m	2.8 m	4.2 m	5.6 m

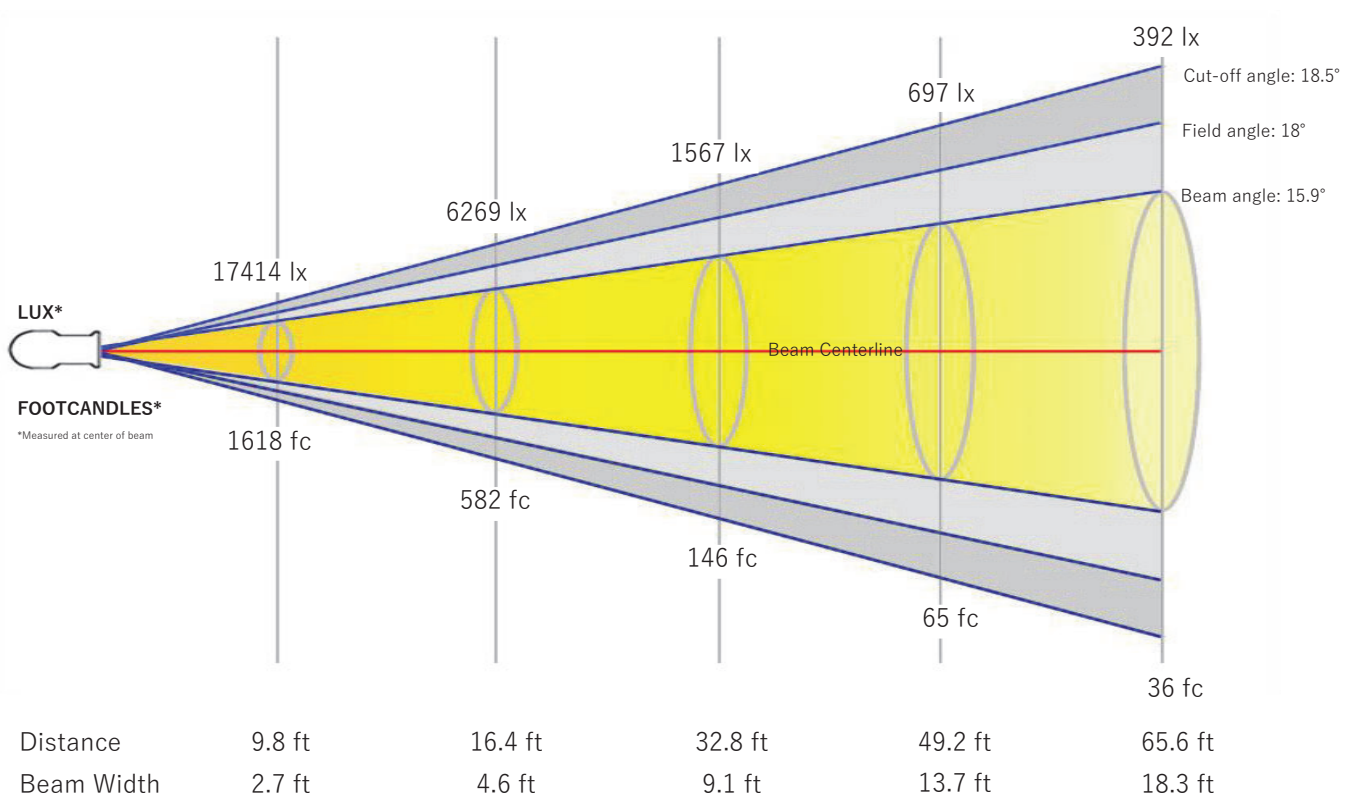

Beam Intensities from 1-20m

M	1	2	3	4	5	6	7	8	9	10	11	12	13	14	15	16	17	18	19	20
LX	156724	39181	17414	9795	6269	4353	3198	2449	1935	1567	1295	1088	927	800	697	612	542	484	434	392
FT	3.3	6.6	9.8	13.1	16.4	19.7	23	26.2	29.5	32.8	36.1	39.4	42.7	45.9	49.2	52.5	55.8	59.1	62.3	65.6
FC	14560.1	3640	1617.8	910	582.4	404.4	297.1	227.5	179.8	145.6	120.3	101.1	86.2	74.3	64.7	56.9	50.4	44.9	40.3	36.4

Angular Distribution

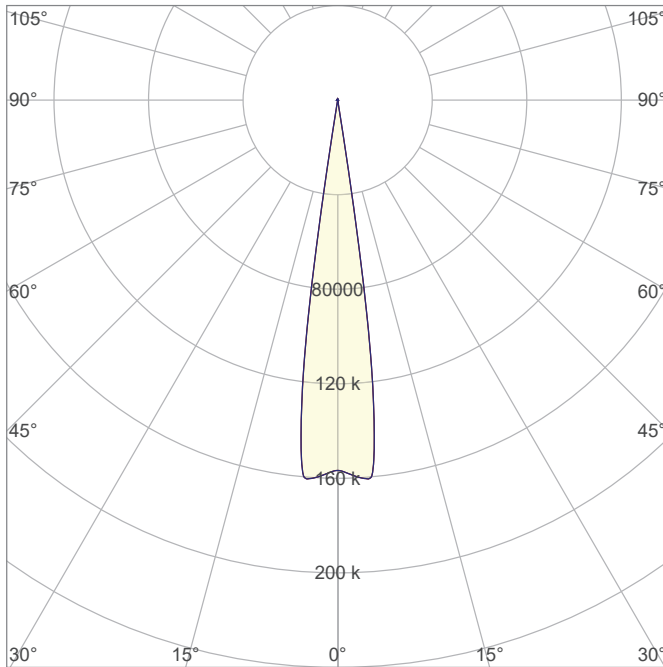

Beam Angle - 50%
15.9°
Field Angle - 10%
18°
Cutoff Angle - 2.5%
18.5°

ISO Diagrams

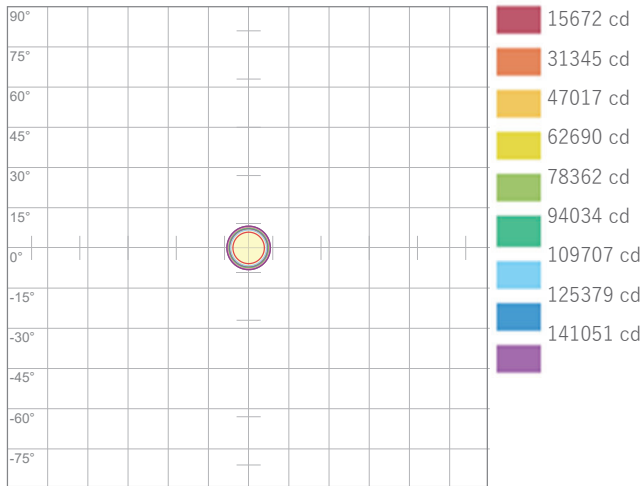

ISO Candela Diagram

Conditions:
Number of c-planes: 8
Candela at center: 156724 cd

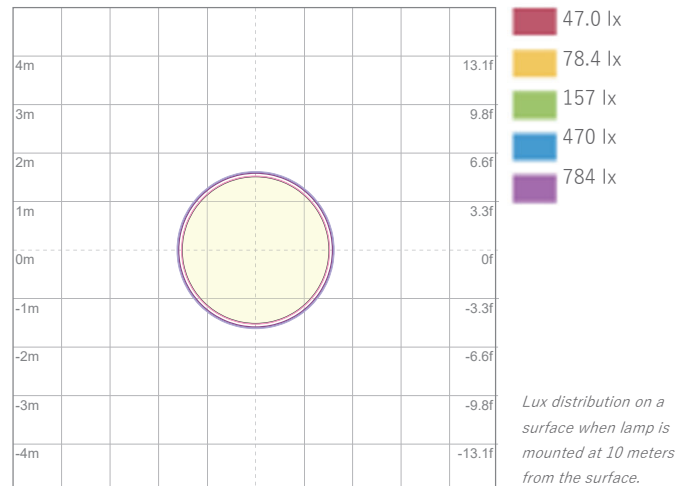

ISO LUX Diagram

Conditions:
Number of c-planes: 8
LUX at center: 1567 lx

Linear Distribution

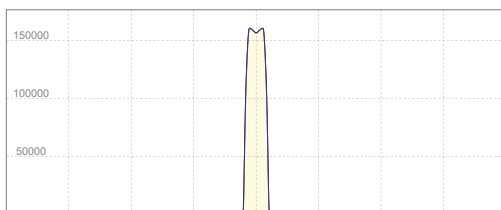

Peak Candela
160700 cd

Calculate Center Beam Intensities

$$\text{lux} = 160700 / \text{distance(m)}^2$$

$$\text{fc} = 160700 / \text{distance(ft)}^2$$

Key Measurements

Output

Total Lumen Output: 6336 lm
Peak Intensity: 103848 cd

Beam

Beam Angle (50%): 15.9°
Field Angle (10%): 18°
Cutoff Angle (2.5%): 18.6°

Color

Color Temperature: 5661 K
CRI: 95.2
TLCI: 94
TM30 R_F: 91.9
TM30 R_g: 100.6

Power Details

Efficacy: 12 Lumen/Watt
Power: 527 W
Supply Voltage: 117 V
Current: 4.49 A

Beam Details

Distance	3 m	5 m	10 m	15 m	20 m
Beam Width	0.8 m	1.4 m	2.8 m	4.2 m	5.6 m

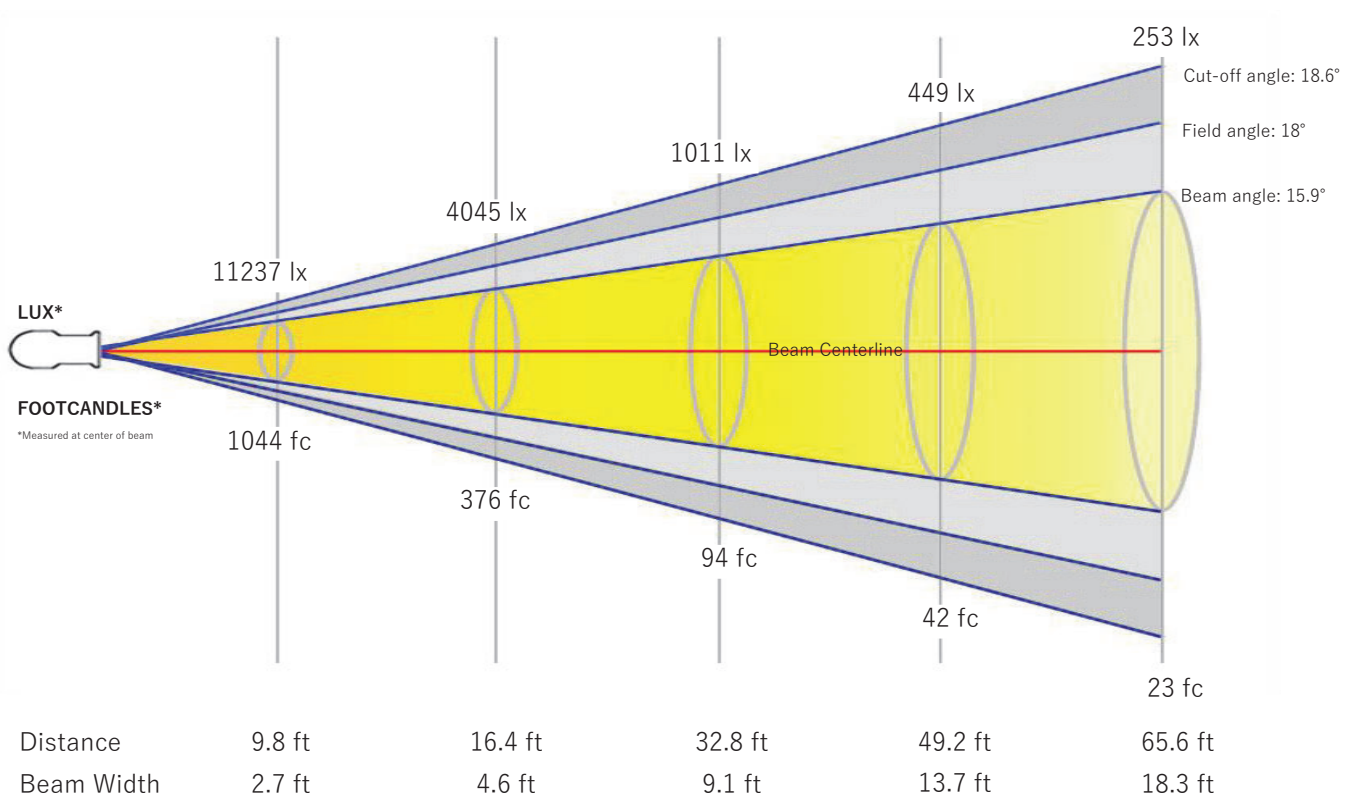

Beam Intensities from 1-20m

M	1	2	3	4	5	6	7	8	9	10	11	12	13	14	15	16	17	18	19	20
LX	101137	25284	11237	6321	4045	2809	2064	1580	1249	1011	836	702	598	516	449	395	350	312	280	253
FT	3.3	6.6	9.8	13.1	16.4	19.7	23	26.2	29.5	32.8	36.1	39.4	42.7	45.9	49.2	52.5	55.8	59.1	62.3	65.6
FC	9395.9	2349	1044	587.2	375.8	261	191.8	146.8	116	94	77.7	65.2	55.6	47.9	41.8	36.7	32.5	29	26	23.5

Angular Distribution

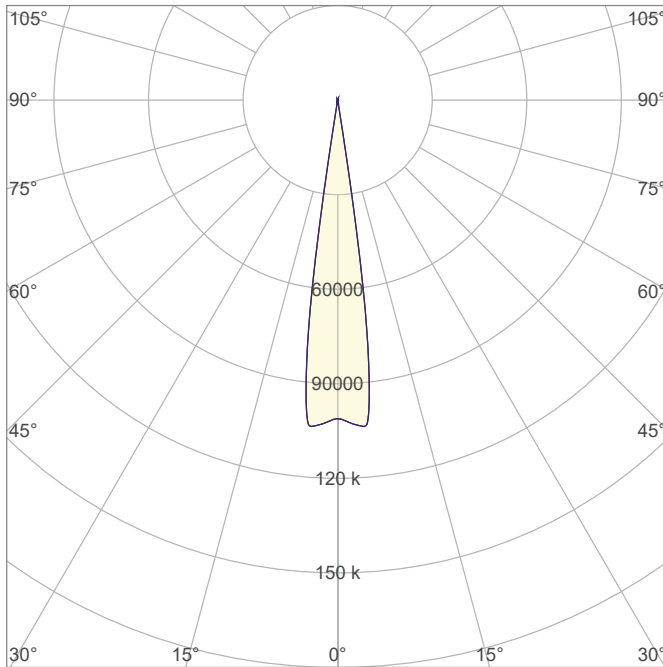

Beam Angle - 50%
15.9°
Field Angle - 10%
18°
Cutoff Angle - 2.5%
18.6°

ISO Diagrams

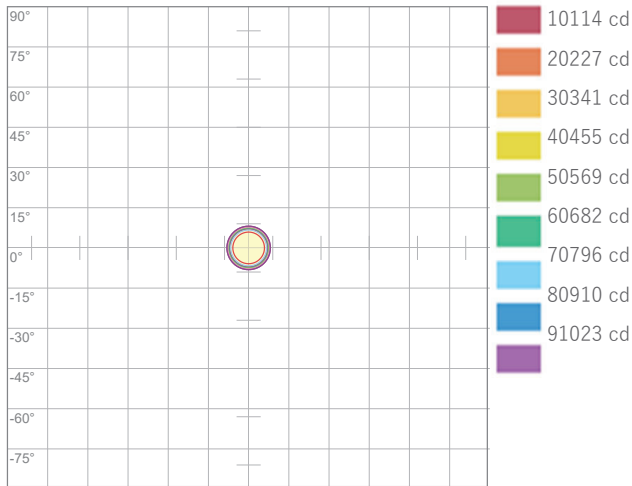

ISO Candela Diagram

Conditions:
Number of c-planes: 8
Candela at center: 101137 cd

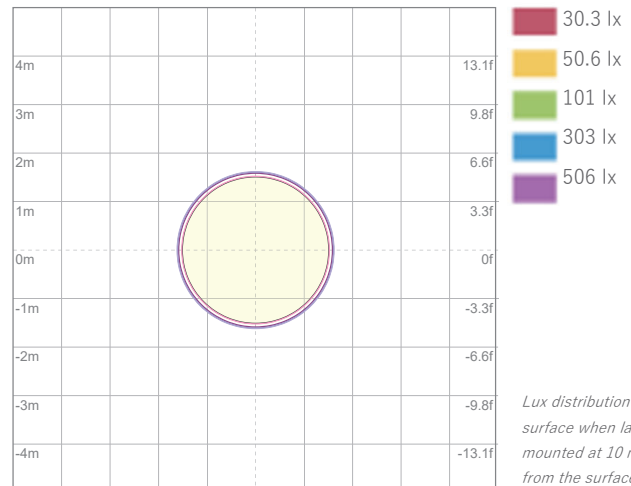

ISO LUX Diagram

Conditions:
Number of c-planes: 8
LUX at center: 1011 lx

Lux distribution on a surface when lamp is mounted at 10 meters from the surface.

Linear Distribution



Peak Candela
103848 cd

Calculate Center Beam Intensities

$$\text{lux} = 103848 / \text{distance(m)}^2$$

$$\text{fc} = 103848 / \text{distance(ft)}^2$$

Key Measurements

Output

Total Lumen Output: 2803 lm
Peak Intensity: 44894 cd

Beam

Beam Angle (50%): 15.9°
Field Angle (10%): 18.1°
Cutoff Angle (2.5%): 18.8°

Color

Color Temperature: 2266 K
CRI: 85.6
TLCI: 62
TM30 R_F: 86.7
TM30 R_g: 102.7

Power Details

Efficacy: 5 Lumen/Watt
Power: 528 W
Supply Voltage: 116 V
Current: 4.55 A

Beam Details

Distance	3 m	5 m	10 m	15 m	20 m
Beam Width	0.8 m	1.4 m	2.8 m	4.2 m	5.6 m

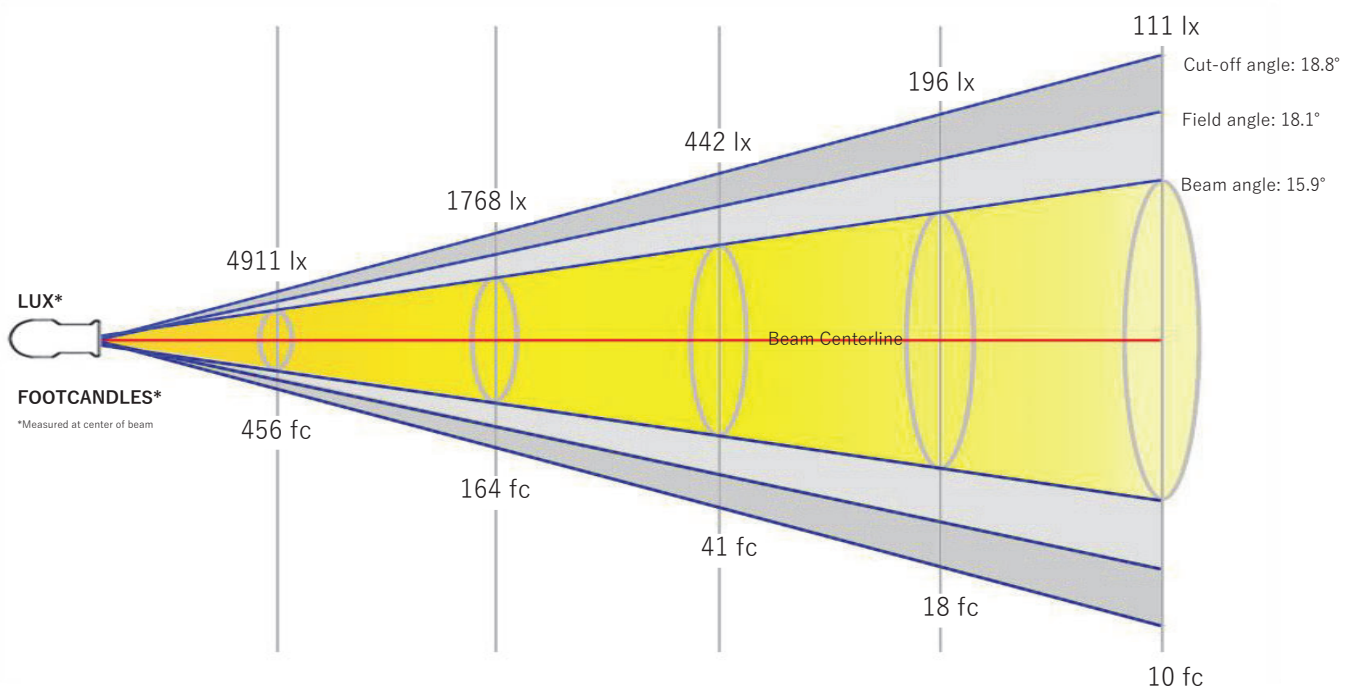

Distance	9.8 ft	16.4 ft	32.8 ft	49.2 ft	65.6 ft
Beam Width	2.7 ft	4.6 ft	9.2 ft	13.7 ft	18.3 ft

Beam Intensities from 1-20m

M	1	2	3	4	5	6	7	8	9	10	11	12	13	14	15	16	17	18	19	20
LX	44202	11050	4911	2763	1768	1228	902	691	546	442	365	307	262	226	196	173	153	136	122	111
FT	3.3	6.6	9.8	13.1	16.4	19.7	23	26.2	29.5	32.8	36.1	39.4	42.7	45.9	49.2	52.5	55.8	59.1	62.3	65.6
FC	4106.5	1026.6	456.3	256.7	164.3	114.1	83.8	64.2	50.7	41.1	33.9	28.5	24.3	21	18.3	16	14.2	12.7	11.4	10.3

Angular Distribution

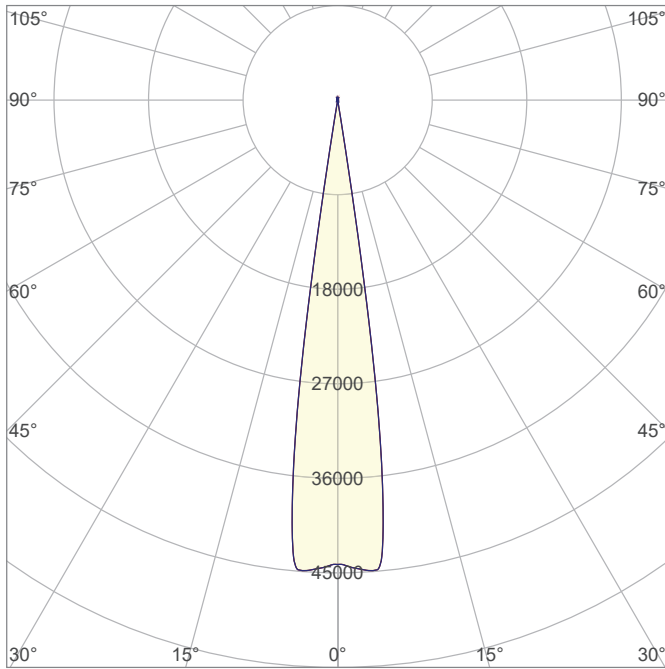

Beam Angle - 50%
15.9°
Field Angle - 10%
18.1°
Cutoff Angle - 2.5%
18.8°

ISO Diagrams

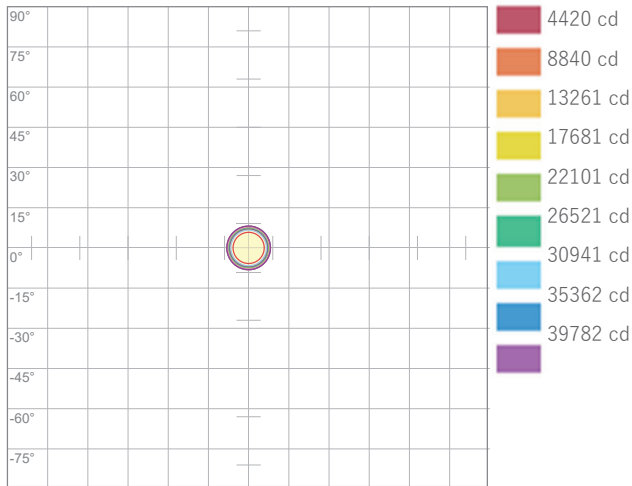

ISO Candela Diagram

Conditions:
Number of c-planes: 8
Candela at center: 44202 cd

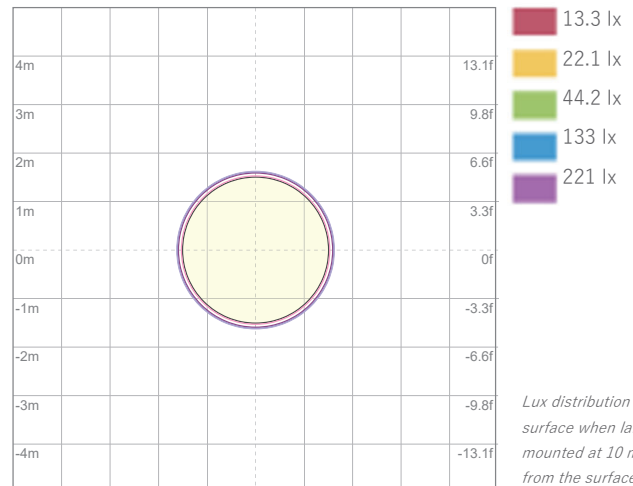

ISO LUX Diagram

Conditions:
Number of c-planes: 8
LUX at center: 442 lx

Lux distribution on a surface when lamp is mounted at 10 meters from the surface.

Linear Distribution

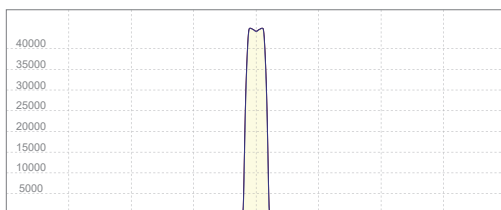

Peak Candela
44894 cd

Calculate Center Beam Intensities

$$\text{lux} = 44894 / \text{distance(m)}^2$$

$$\text{fc} = 44894 / \text{distance(ft)}^2$$

Key Measurements

Output

Total Lumen Output: 2162 lm

Peak Intensity: 34945 cd

Beam

Beam Angle (50%): 15.9°

Field Angle (10%): 18.2°

Cutoff Angle (2.5%): 18.9°

Color

Color Temperature: 2255 K

CRI: 83.3

TLCI: 57

TM30 R_F: 84.7

TM30 R_g: 104.4

Power Details

Efficacy: 4 Lumen/Watt

Power: 525 W

Supply Voltage: 115 V

Current: 4.57 A

Beam Details

Distance	3 m	5 m	10 m	15 m	20 m
Beam Width	0.8 m	1.4 m	2.8 m	4.2 m	5.6 m

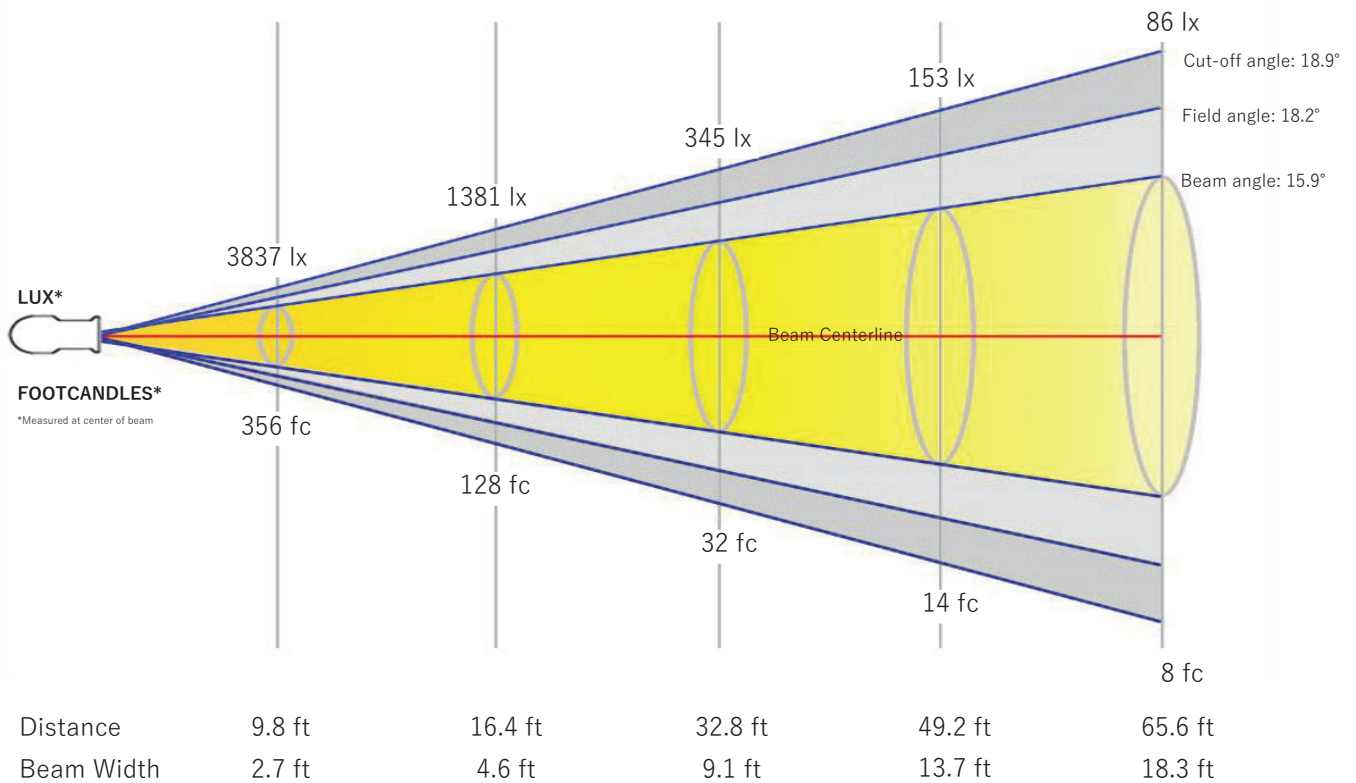

Beam Intensities from 1-20m

M	1	2	3	4	5	6	7	8	9	10	11	12	13	14	15	16	17	18	19	20
LX	34531	8633	3837	2158	1381	959	705	540	426	345	285	240	204	176	153	135	119	107	96	86
FT	3.3	6.6	9.8	13.1	16.4	19.7	23	26.2	29.5	32.8	36.1	39.4	42.7	45.9	49.2	52.5	55.8	59.1	62.3	65.6
FC	3208.1	802	356.5	200.5	128.3	89.1	65.5	50.1	39.6	32.1	26.5	22.3	19	16.4	14.3	12.5	11.1	9.9	8.9	8

Angular Distribution

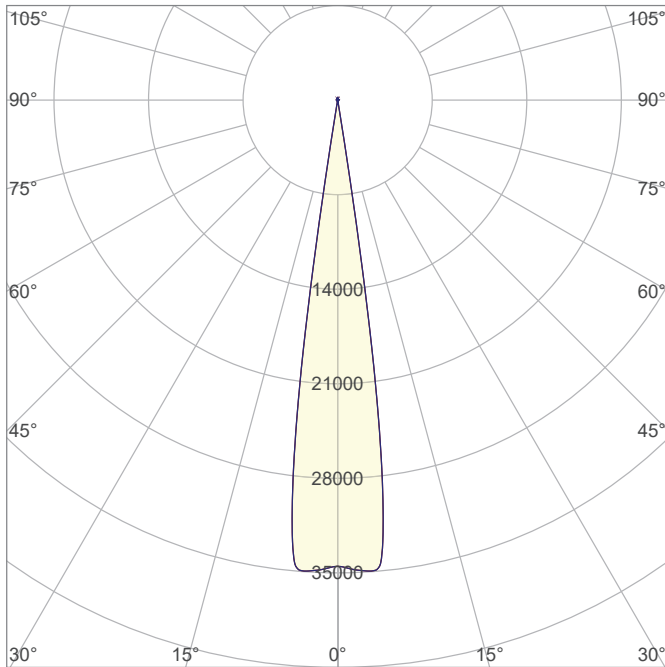

Beam Angle - 50%
15.9°
Field Angle - 10%
18.2°
Cutoff Angle - 2.5%
18.9°

ISO Diagrams

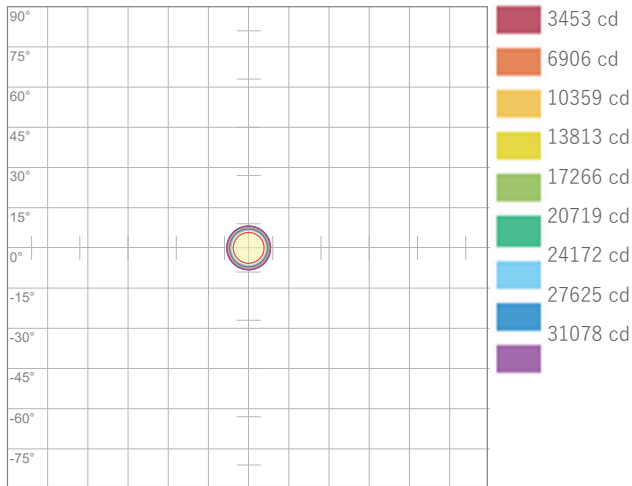

ISO Candela Diagram

Conditions:
Number of c-planes: 8
Candela at center: 34531 cd

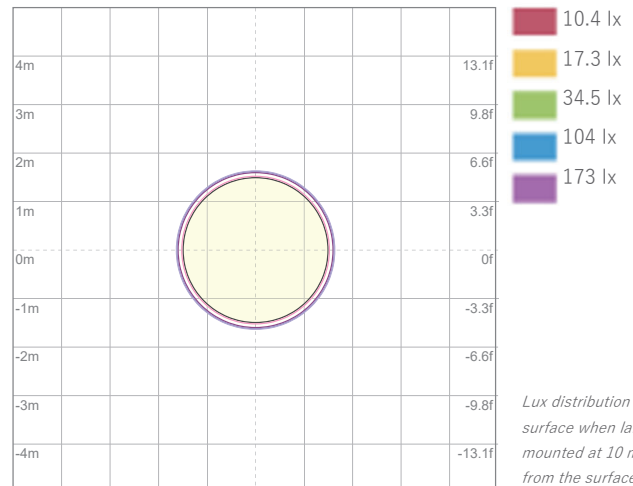

ISO LUX Diagram

Conditions:
Number of c-planes: 8
LUX at center: 345 lx

Lux distribution on a surface when lamp is mounted at 10 meters from the surface.

Linear Distribution

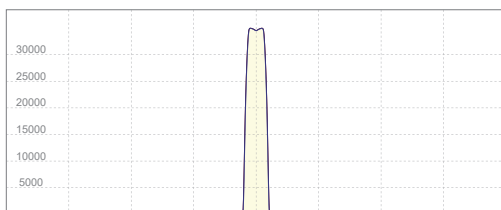

Peak Candela
34945 cd

Calculate Center Beam Intensities

$$\text{lux} = 34945 / \text{distance(m)}^2$$

$$\text{fc} = 34945 / \text{distance(ft)}^2$$

Key Measurements

Output

Total Lumen Output: 12295 lm
Peak Intensity: 196333 cd

Beam

Beam Angle (50%): 16°
Field Angle (10%): 18.2°
Cutoff Angle (2.5%): 18.8°

Color

Color Temperature: 6459 K
CRI: 71.5
TLCI: 49
TM30 R_F: 72.2
TM30 R_g: 93.5

Power Details

Efficacy: 26 Lumen/Watt
Power: 464 W
Supply Voltage: 115 V
Current: 4.03 A

Beam Details

Distance	3 m	5 m	10 m	15 m	20 m
Beam Width	0.8 m	1.4 m	2.8 m	4.2 m	5.6 m

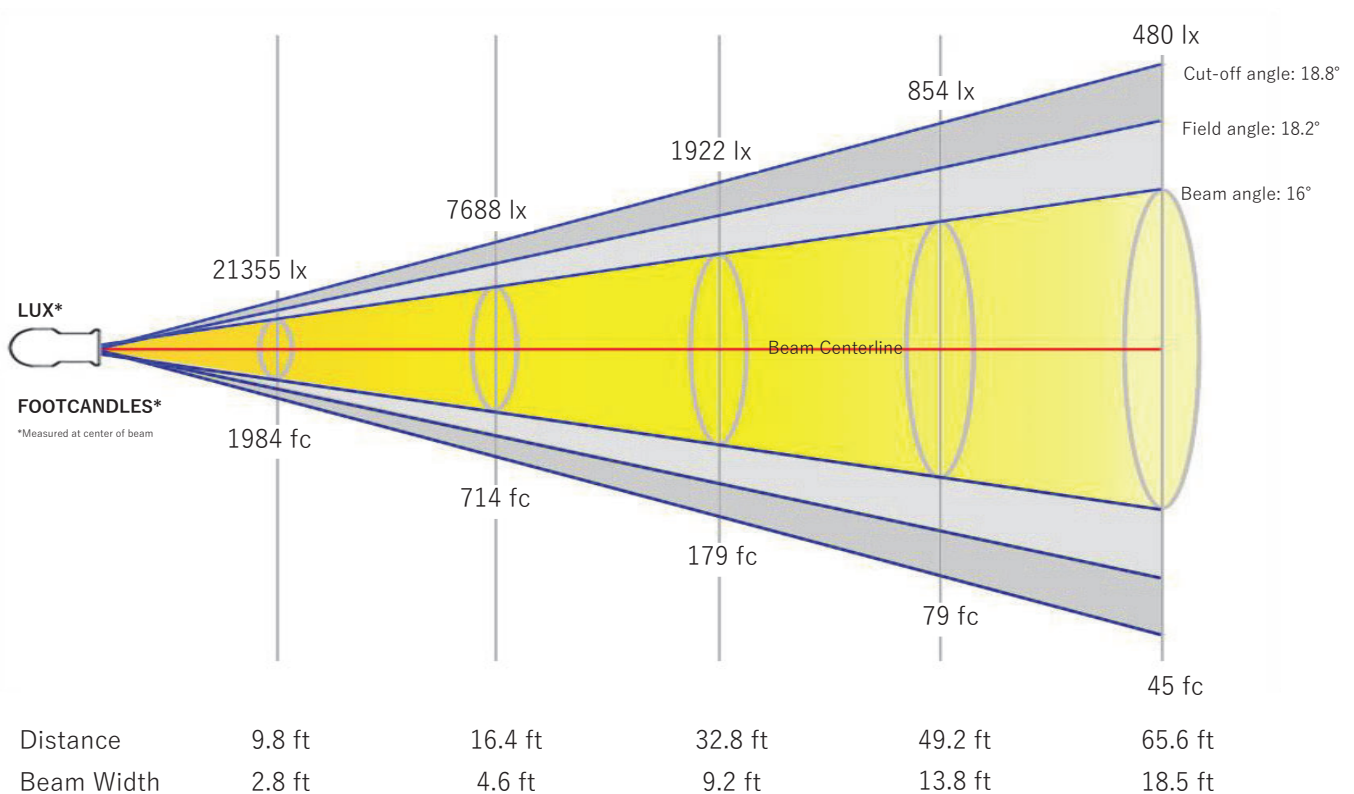

Beam Intensities from 1-20m

M	1	2	3	4	5	6	7	8	9	10	11	12	13	14	15	16	17	18	19	20
LX	192196	48049	21355	12012	7688	5339	3922	3003	2373	1922	1588	1335	1137	981	854	751	665	593	532	480
FT	3.3	6.6	9.8	13.1	16.4	19.7	23	26.2	29.5	32.8	36.1	39.4	42.7	45.9	49.2	52.5	55.8	59.1	62.3	65.6
FC	17855.6	4463.9	1984	1116	714.2	496	364.4	279	220.4	178.6	147.6	124	105.7	91.1	79.4	69.7	61.8	55.1	49.5	44.6

Angular Distribution

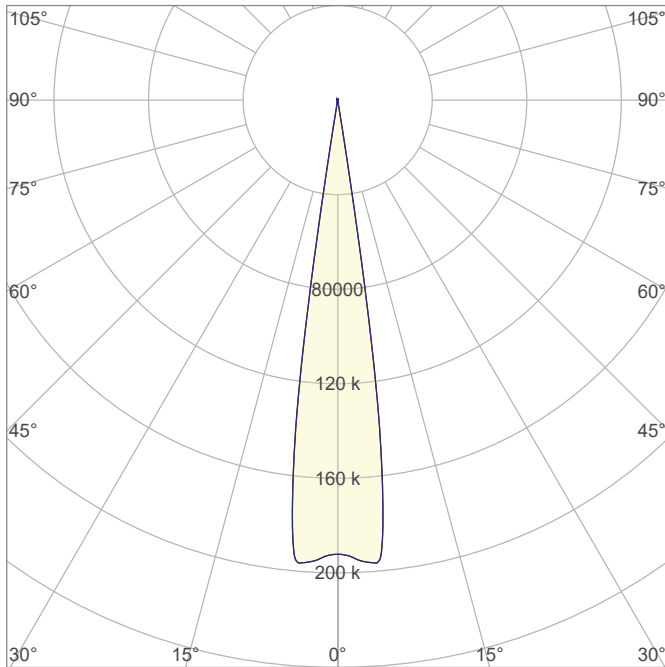

Beam Angle - 50%
16°
Field Angle - 10%
18.2°
Cutoff Angle - 2.5%
18.8°

ISO Diagrams

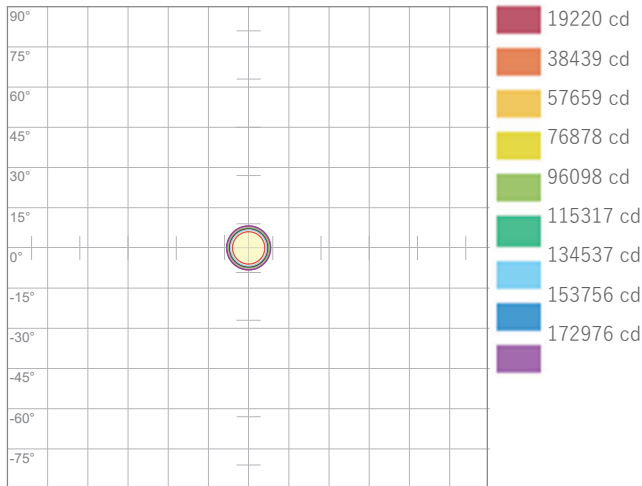

ISO Candela Diagram

Conditions:
Number of c-planes: 8
Candela at center: 192196 cd

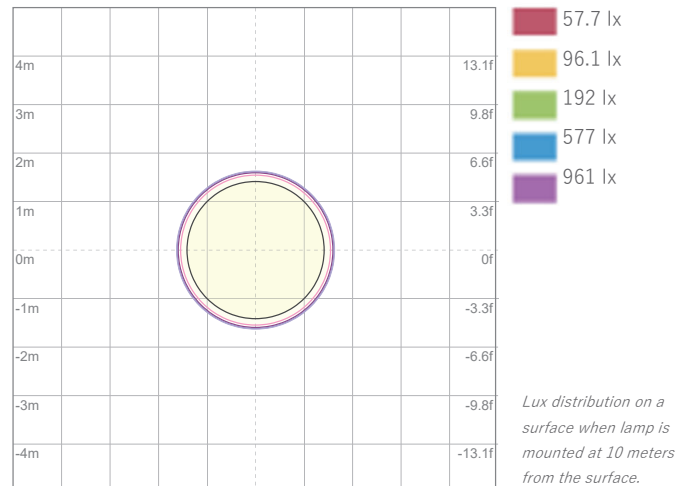

ISO LUX Diagram

Conditions:
Number of c-planes: 8
LUX at center: 1922 lx

Lux distribution on a surface when lamp is mounted at 10 meters from the surface.

Linear Distribution

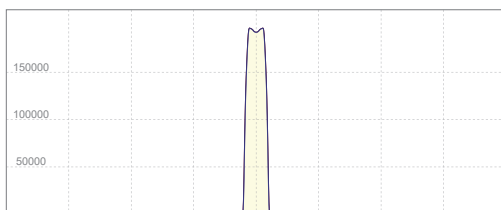

Peak Candela
196333 cd

Calculate Center Beam Intensities

$$\text{lux} = 196333 / \text{distance(m)}^2$$

$$\text{fc} = 196333 / \text{distance(ft)}^2$$

Key Measurements

Output

Total Lumen Output: 9225 lm
Peak Intensity: 149287 cd

Beam

Beam Angle (50%): 16°
Field Angle (10%): 18.2°
Cutoff Angle (2.5%): 18.7°

Color

Color Temperature: 6410 K
CRI: 71.0
TLCI: 48
TM30 R_F: 71.8
TM30 R_g: 93.7

Power Details

Efficacy: 26 Lumen/Watt
Power: 360 W
Supply Voltage: 116 V
Current: 3.10 A

Beam Details

Distance	3 m	5 m	10 m	15 m	20 m
Beam Width	0.8 m	1.4 m	2.8 m	4.2 m	5.6 m

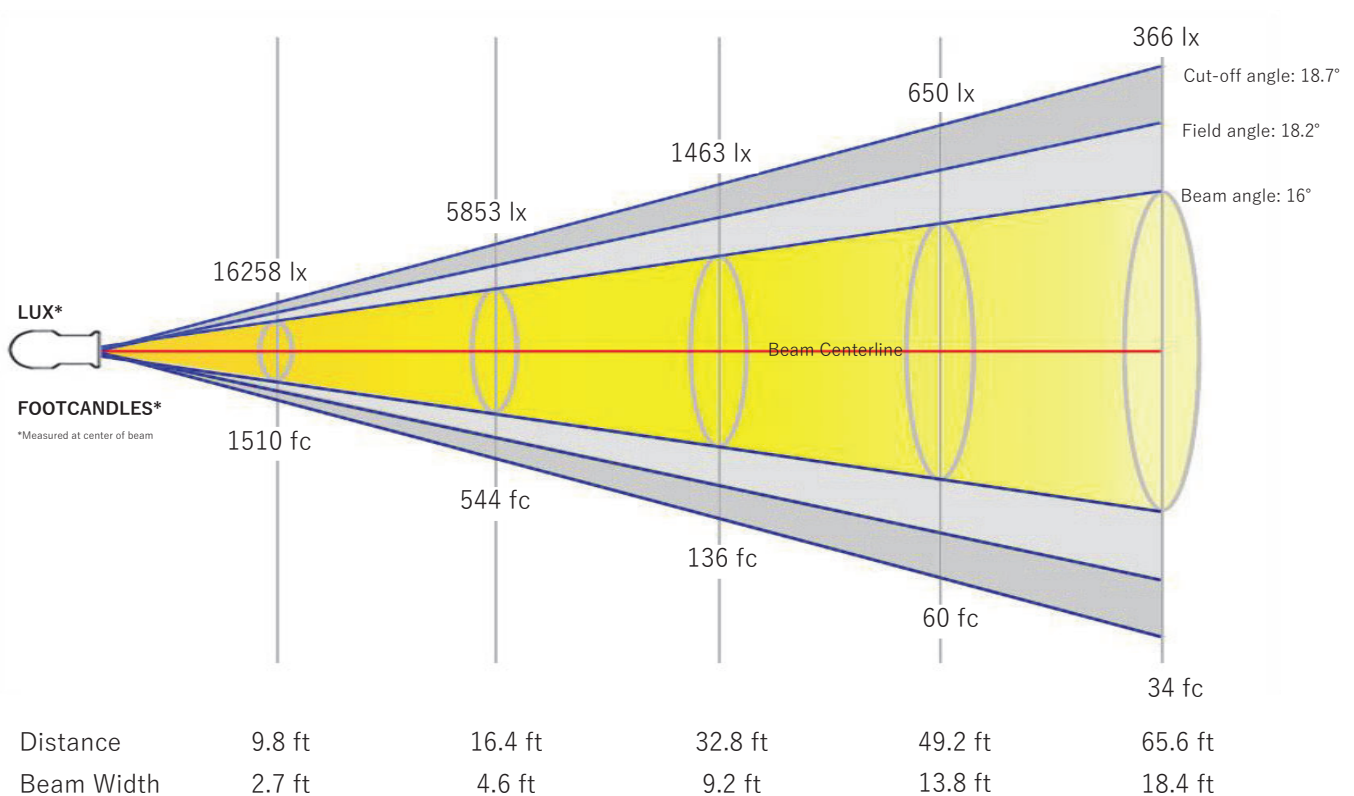

Beam Intensities from 1-20m

M	1	2	3	4	5	6	7	8	9	10	11	12	13	14	15	16	17	18	19	20
LX	146326	36582	16258	9145	5853	4065	2986	2286	1806	1463	1209	1016	866	747	650	572	506	452	405	366
FT	3.3	6.6	9.8	13.1	16.4	19.7	23	26.2	29.5	32.8	36.1	39.4	42.7	45.9	49.2	52.5	55.8	59.1	62.3	65.6
FC	13594.2	3398.5	1510.5	849.6	543.8	377.6	277.4	212.4	167.8	135.9	112.3	94.4	80.4	69.4	60.4	53.1	47	42	37.7	34

Angular Distribution

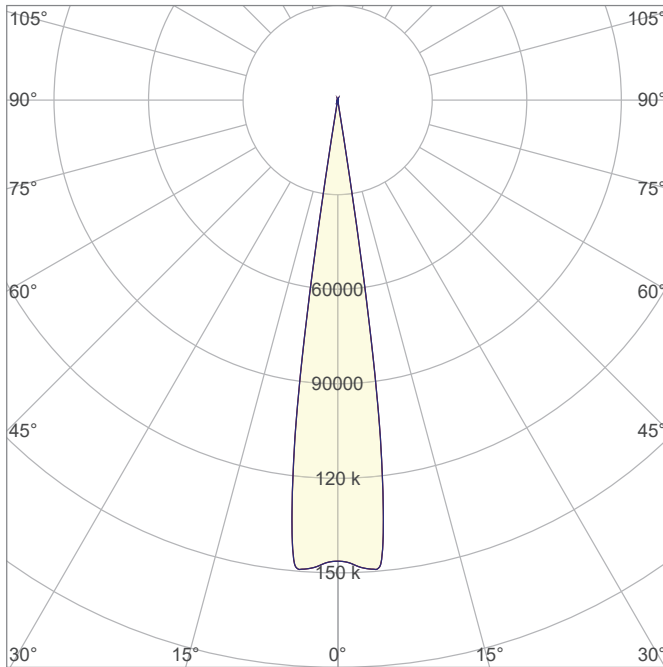

Beam Angle - 50%
16°
Field Angle - 10%
18.2°
Cutoff Angle - 2.5%
18.7°

ISO Diagrams

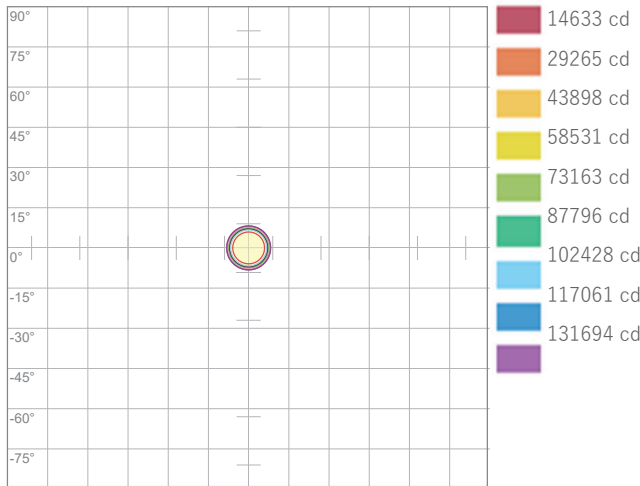

ISO Candela Diagram

Conditions:
Number of c-planes: 8
Candela at center: 146326 cd

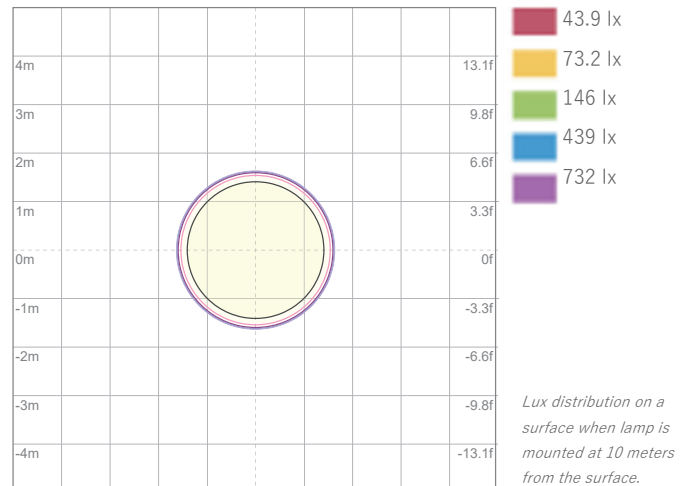

ISO LUX Diagram

Conditions:
Number of c-planes: 8
LUX at center: 1463 lx

Lux distribution on a surface when lamp is mounted at 10 meters from the surface.

Linear Distribution

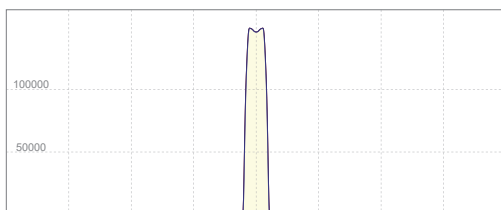

Peak Candela
149287 cd

Calculate Center Beam Intensities

$$\text{lux} = 149287 / \text{distance(m)}^2$$

$$\text{fc} = 149287 / \text{distance(ft)}^2$$

Key Measurements

Output

Total Lumen Output: 1137 lm

Peak Intensity: 18537 cd

Beam

Beam Angle (50%): 16°

Field Angle (10%): 18.1°

Cutoff Angle (2.5%): 18.7°

Color

Color Temperature: 6276 K

CRI: 69.9

TLCI: 47

TM30 R_F: 71.0

TM30 R_g: 93.8

Power Details

Efficacy: 10 Lumen/Watt

Power: 118.9 W

Supply Voltage: 119 V

Current: 0.999 A

Beam Details

Distance	3 m	5 m	10 m	15 m	20 m
Beam Width	0.8 m	1.4 m	2.8 m	4.2 m	5.6 m

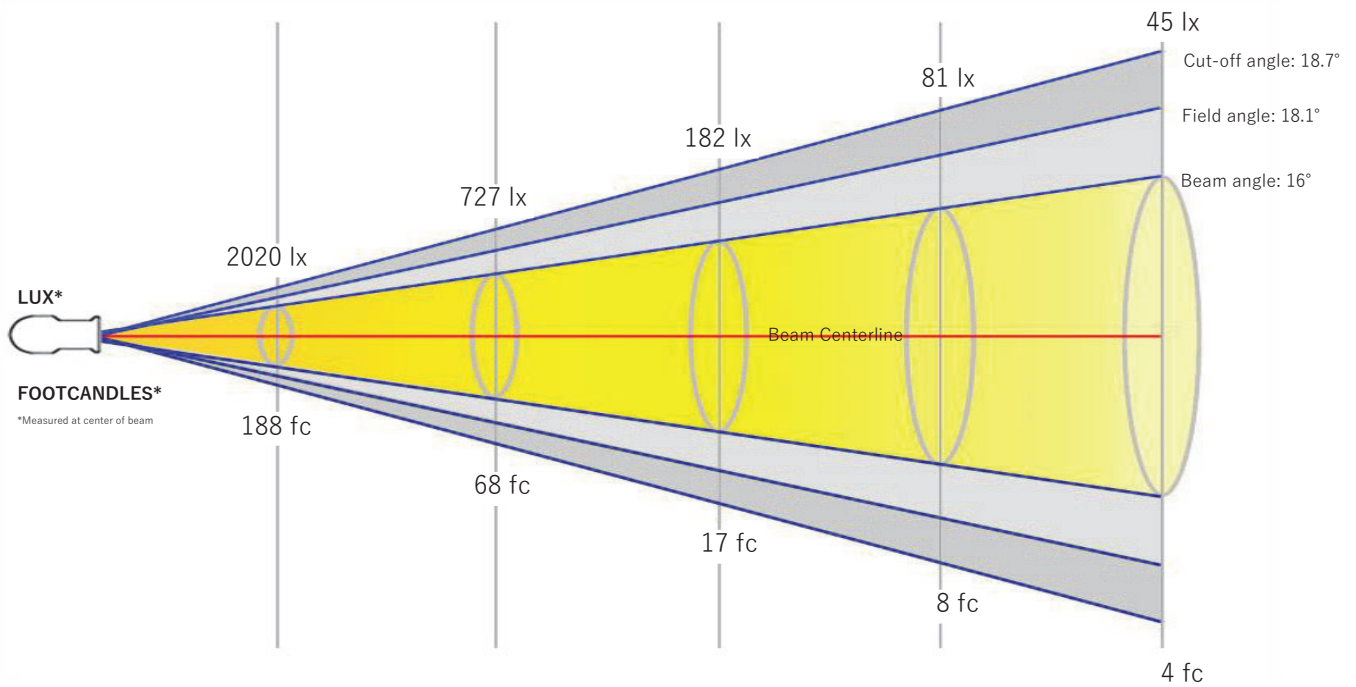

Distance	9.8 ft	16.4 ft	32.8 ft	49.2 ft	65.6 ft
Beam Width	2.7 ft	4.6 ft	9.2 ft	13.8 ft	18.4 ft

Beam Intensities from 1-20m

M	1	2	3	4	5	6	7	8	9	10	11	12	13	14	15	16	17	18	19	20
LX	18176	4544	2020	1136	727	505	371	284	224	182	150	126	108	93	81	71	63	56	50	45
FT	3.3	6.6	9.8	13.1	16.4	19.7	23	26.2	29.5	32.8	36.1	39.4	42.7	45.9	49.2	52.5	55.8	59.1	62.3	65.6
FC	1688.6	422.2	187.6	105.5	67.5	46.9	34.5	26.4	20.8	16.9	14	11.7	10	8.6	7.5	6.6	5.8	5.2	4.7	4.2

Angular Distribution

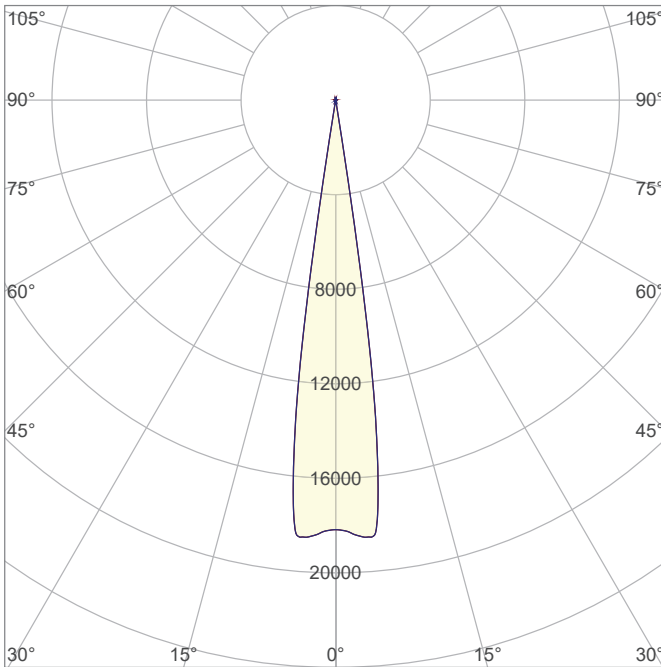

Beam Angle - 50%
16°
Field Angle - 10%
18.1°
Cutoff Angle - 2.5%
18.7°

ISO Diagrams

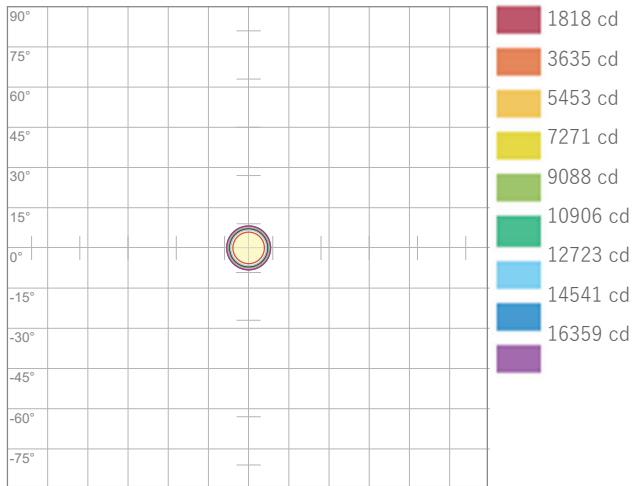

ISO Candela Diagram

Conditions:
Number of c-planes: 8
Candela at center: 18176 cd

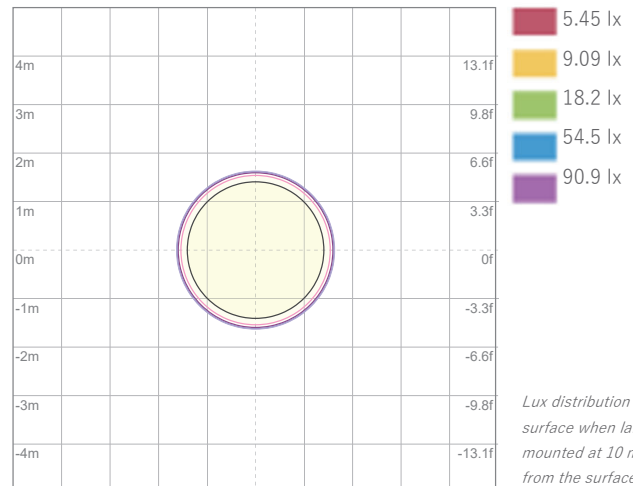

ISO LUX Diagram

Conditions:
Number of c-planes: 8
LUX at center: 182 lx

Lux distribution on a surface when lamp is mounted at 10 meters from the surface.

Linear Distribution

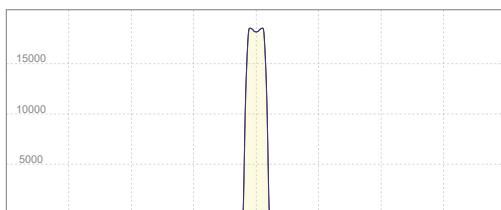

Peak Candela
18537 cd

Calculate Center Beam Intensities

$$\text{lux} = 18537 / \text{distance(m)}^2$$

$$\text{fc} = 18537 / \text{distance(ft)}^2$$

Color Temperature: 6489K

Accuracy Metric Overview

Color Rendering Index	Color Rendering Index, R9 (Red Component)	TM-30 Color Fidelity	TM-30 Color Gamut	Television Lighting Consistency Index	Color Quality Scale	Color Coordinate- CIE 1931	Color Coordinate- CIE 1931	Deviation from Black Body	SSI [CIE A] Tungsten	SSI [CIE D65] Daylight
CRI	CRI R9	TM30 R _f	TM30 R _g	TLCI	CQS	x	Y	Δuv	SSI _t	SSI _d
71.8	-31.8	72.5	93.4	49	69.5	0.313	0.328	0.0024	15	53

CIE 1931

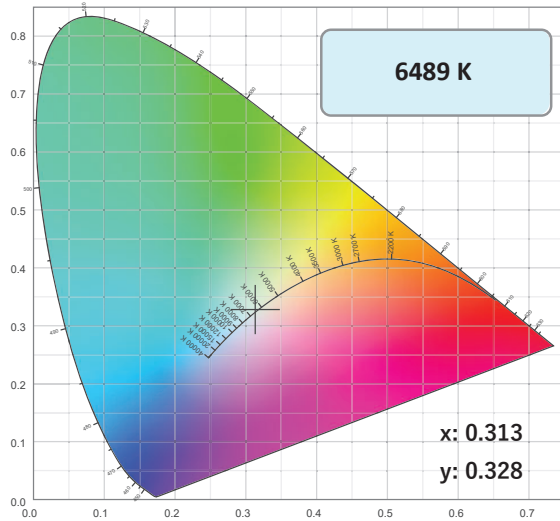

CIE 1931 ZOOMED

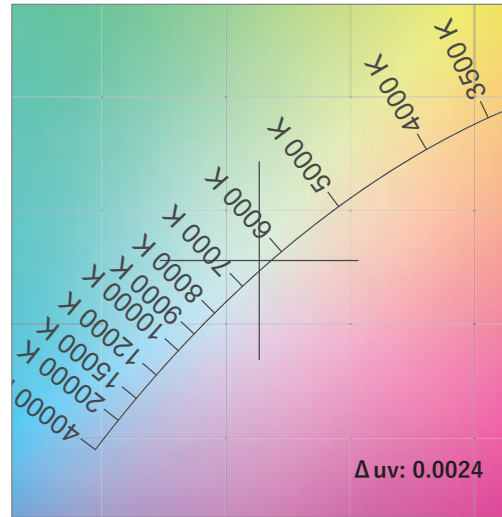

CRI: 71.8 (R1-R8)

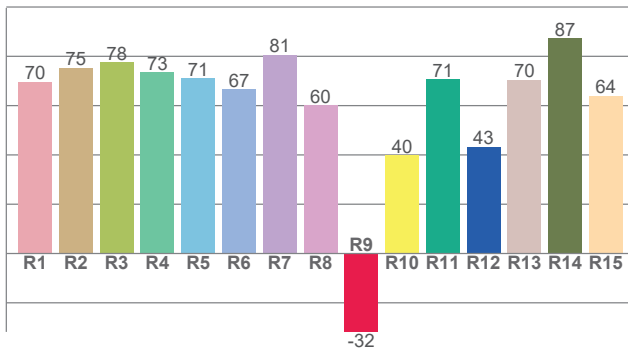

Spectral Power Distribution (SPD)

Dominant Wavelength 517 nm

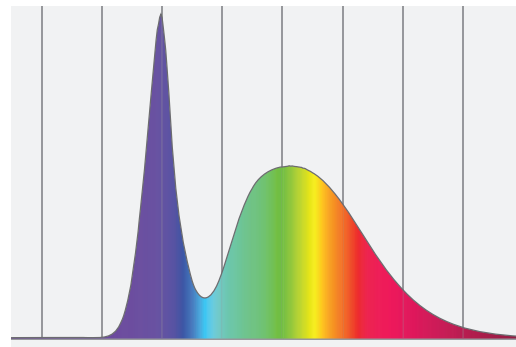

SSI Spectral Variance Graph- Tungsten

SSI [CIE A] 15

Spectral variance

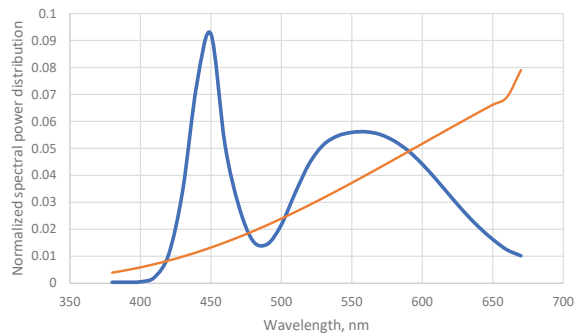

— Test Source — CIE Illuminant A - Tungsten

SSI Spectral Variance Graph- Daylight

SSI [CIE D65] 53

Spectral variance

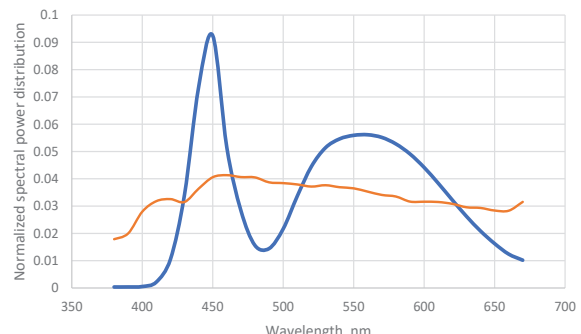

— Test Source — CIE Illuminant D65 - Daylight

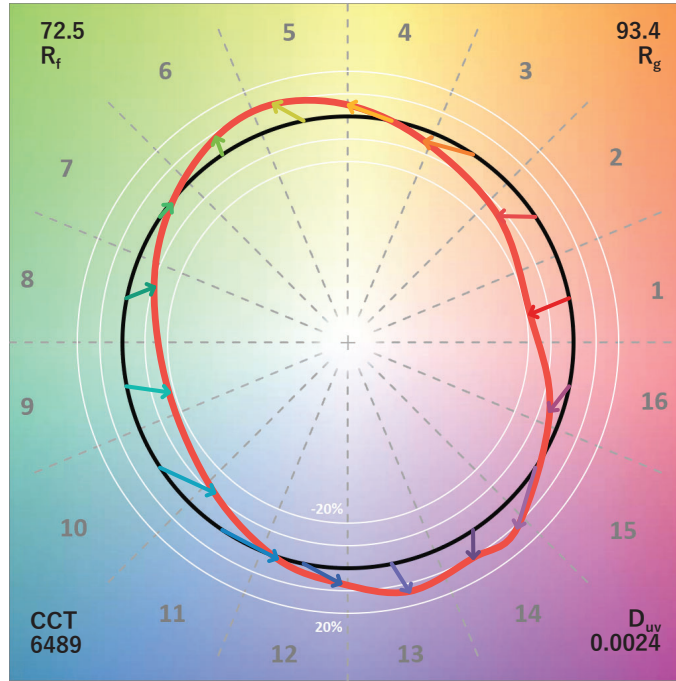

TM30-18 R_f Values per Hue Bin

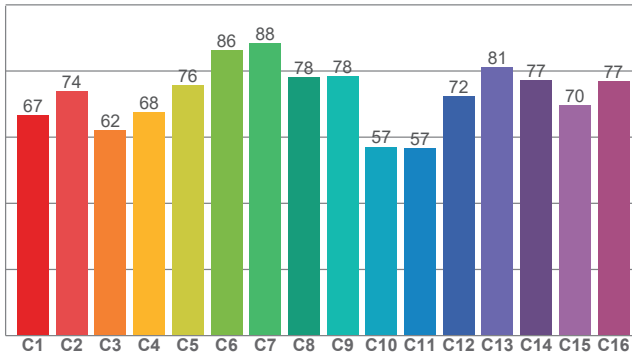

TM30 Chroma Shift per Hue Bin

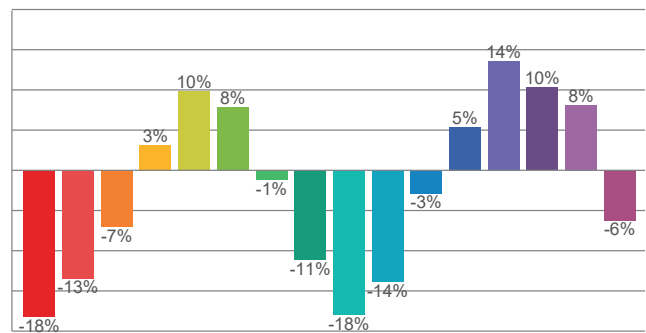

TM30-18 R_f Values per Reference Color (CES)

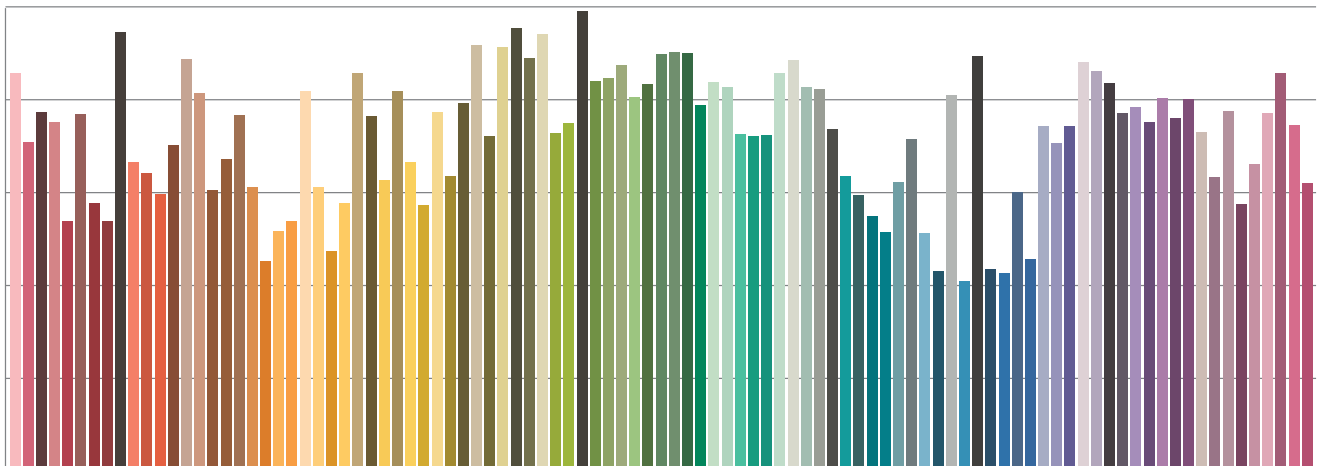

Color Temperature: 2356K

Accuracy Metric Overview

Color Rendering Index	Color Rendering Index, R9 (Red Component)	TM-30 Color Fidelity	TM-30 Color Gamut	Television Lighting Consistency Index	Color Quality Scale	Color Coordinate- CIE 1931	Color Coordinate- CIE 1931	Deviation from Black Body	SSI [CIE A] Tungsten	SSI [CIE D65] Daylight
CRI	CRI R9	TM30 R _f	TM30 R _g	TLCI	CQS	x	Y	Δuv	SSIt	SSId
91.1	65.7	89.3	100.9	75	86.4	0.490	0.414	-0.0002	75	25

CIE 1931

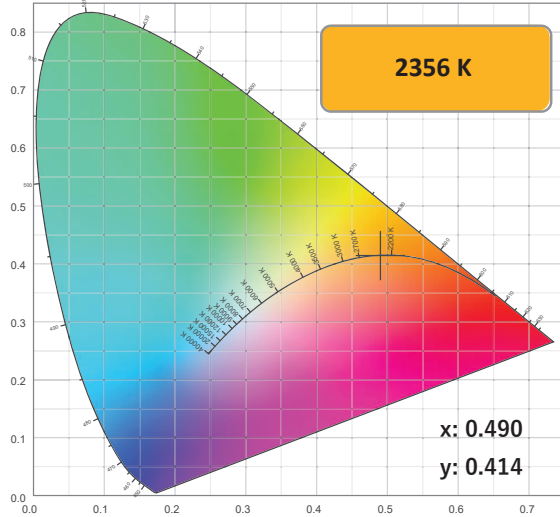

CIE 1931 ZOOMED

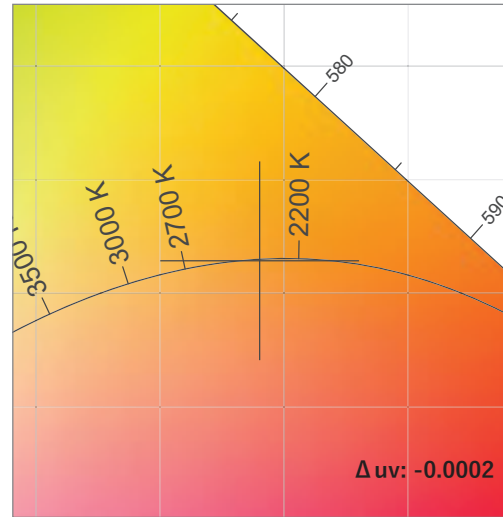

CRI: 91.1 (R1-R8)

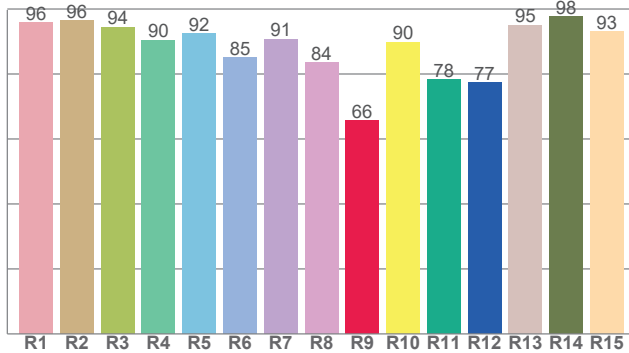

Spectral Power Distribution (SPD)

Dominant Wavelength 587 nm

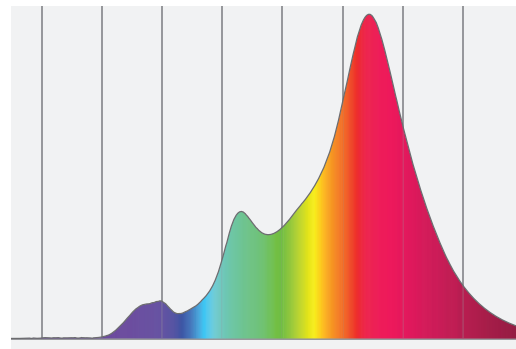

SSI Spectral Variance Graph- Tungsten

SSI [CIE A] 75

Spectral variance

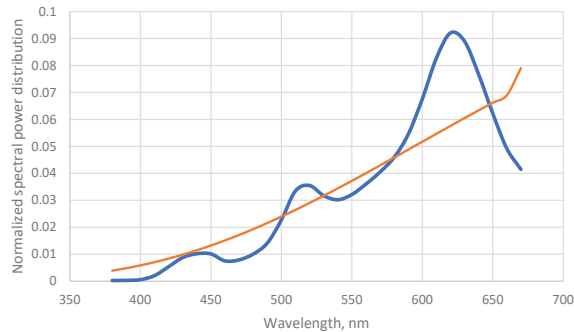

— Test Source — CIE Illuminant A - Tungsten

SSI Spectral Variance Graph- Daylight

SSI [CIE D65] 25

Spectral variance

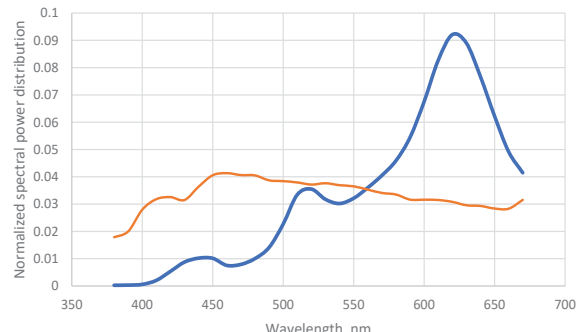

— Test Source — CIE Illuminant D65 - Daylight

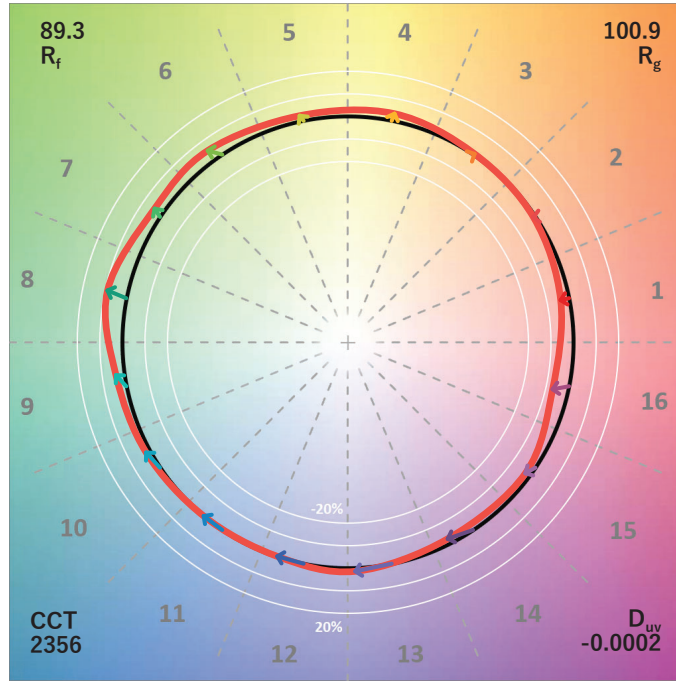

TM30-18 R_f Values per Hue Bin

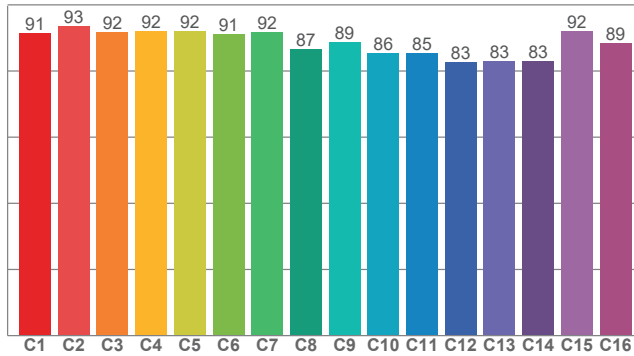

TM30 Chroma Shift per Hue Bin

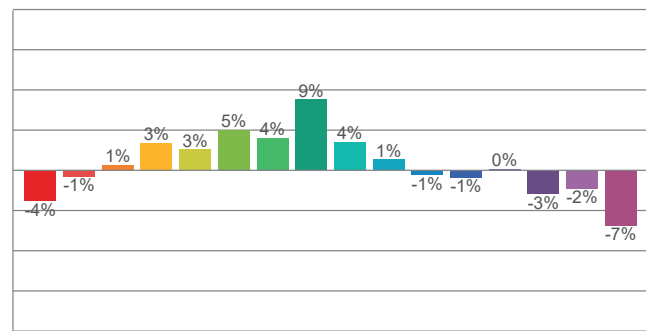

TM30-18 R_f Values per Reference Color (CES)

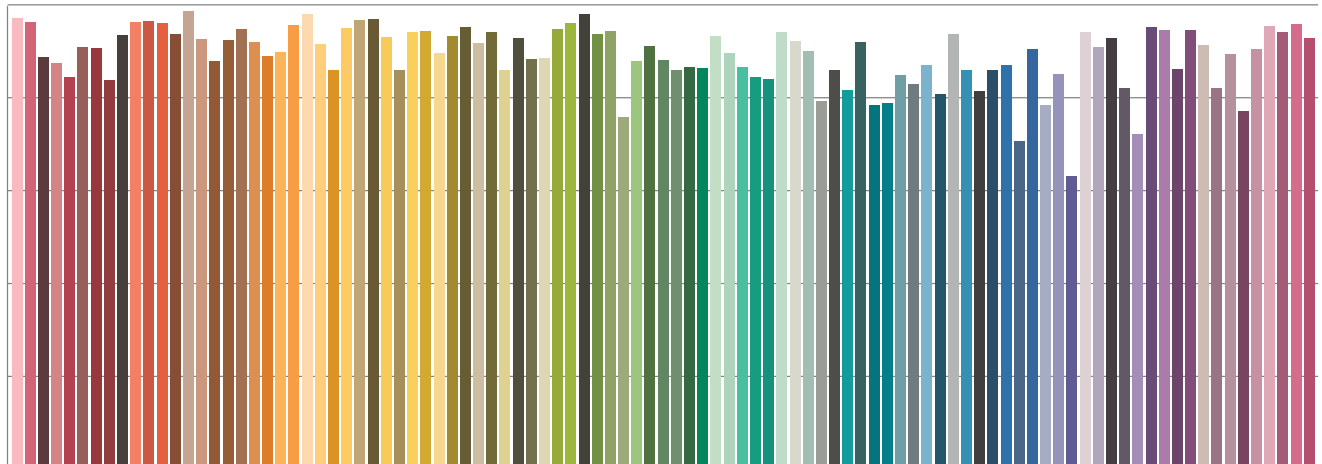

Color Temperature: 6593K

Accuracy Metric Overview

Color Rendering Index	Color Rendering Index, R9 (Red Component)	TM-30 Color Fidelity	TM-30 Color Gamut	Television Lighting Consistency Index	Color Quality Scale	Color Coordinate- CIE 1931	Color Coordinate- CIE 1931	Deviation from Black Body	SSI [CIE A] Tungsten	SSI [CIE D65] Daylight
CRI	CRI R9	TM30 R _f	TM30 R _g	TLCI	CQS	x	Y	Δuv	SSI _t	SSI _d
88.7	44.0	84.6	100.8	79	83.8	0.313	0.314	-0.0048	15	54

CIE 1931

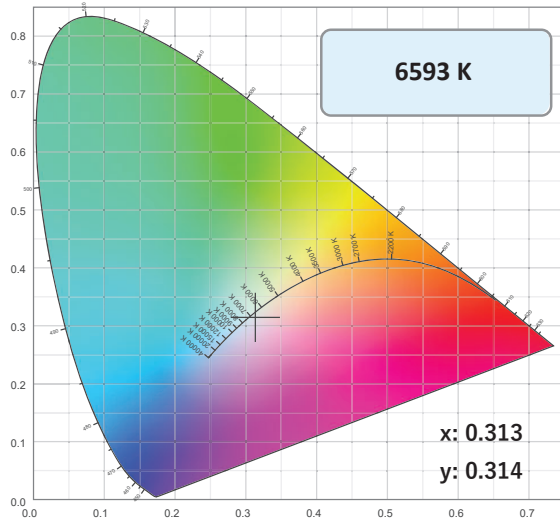

CIE 1931 ZOOMED

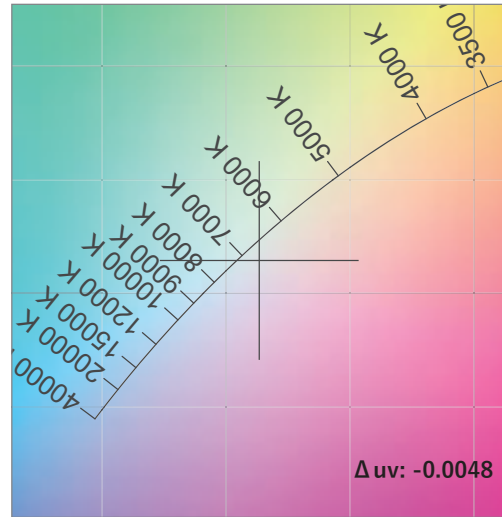

CRI: 88.7 (R1-R8)

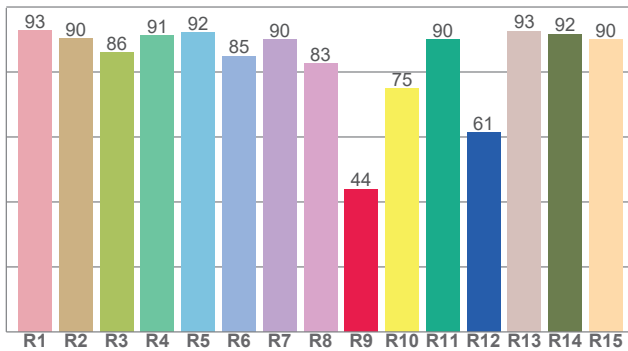

Spectral Power Distribution (SPD)

Dominant Wavelength 549 nm

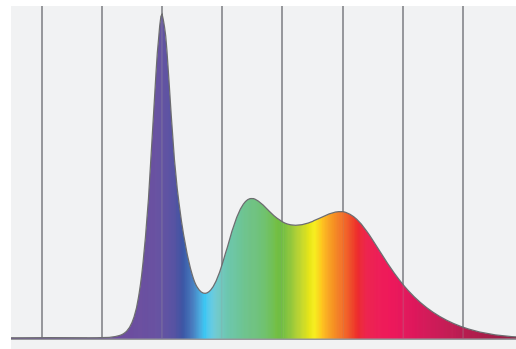

SSI Spectral Variance Graph- Tungsten

SSI [CIE A] 15

Spectral variance

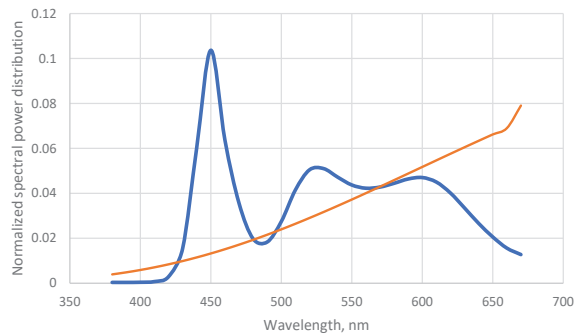

— Test Source — CIE Illuminant A - Tungsten

SSI Spectral Variance Graph- Daylight

SSI [CIE D65] 54

Spectral variance

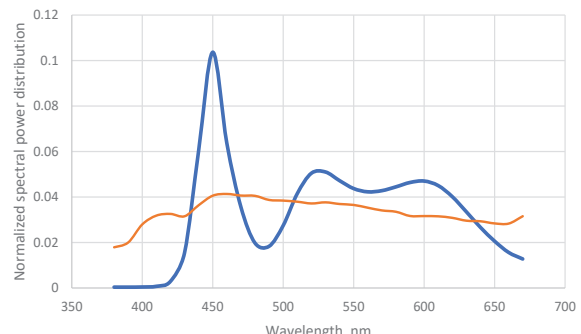

— Test Source — CIE Illuminant D65 - Daylight

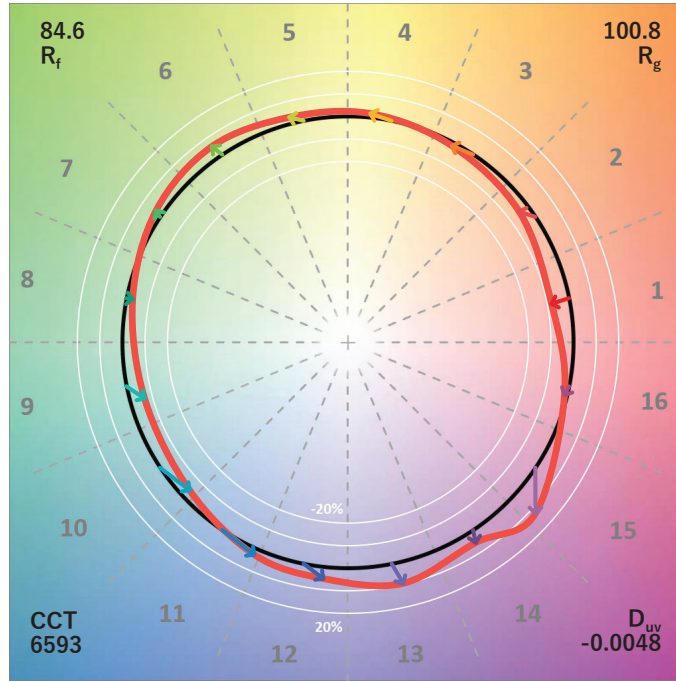

TM30-18 R_f Values per Hue Bin

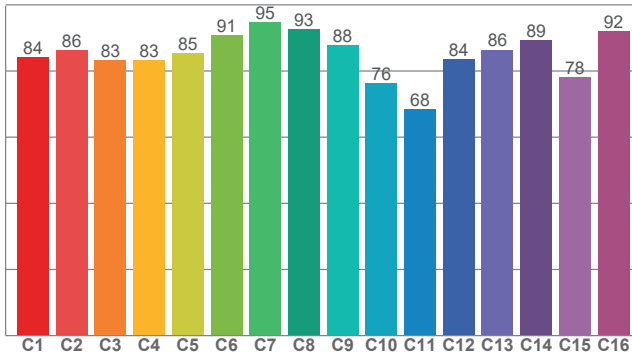

TM30 Chroma Shift per Hue Bin

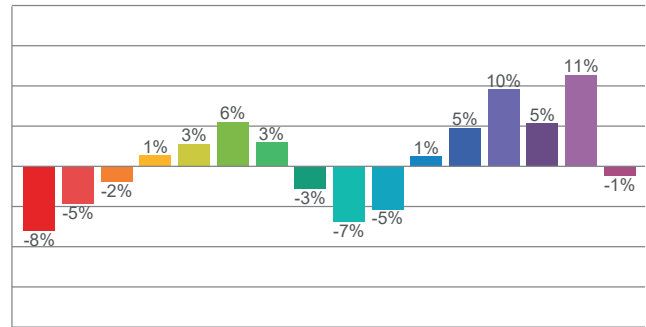

TM30-18 R_f Values per Reference Color (CES)

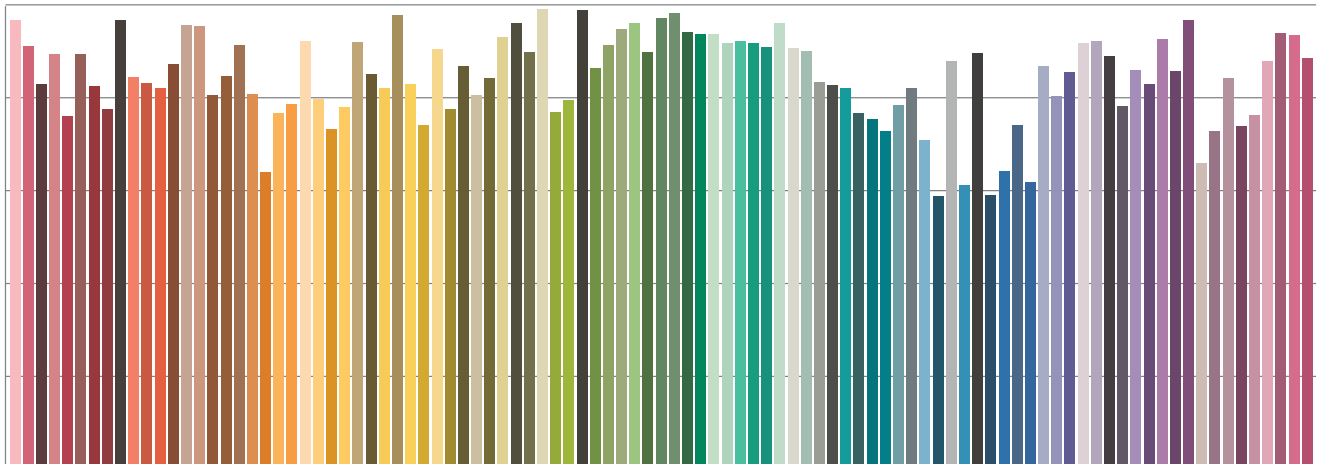

Color Temperature: 5661K

Accuracy Metric Overview

Color Rendering Index	Color Rendering Index, R9 (Red Component)	TM-30 Color Fidelity	TM-30 Color Gamut	Television Lighting Consistency Index	Color Quality Scale	Color Coordinate- CIE 1931	Color Coordinate- CIE 1931	Deviation from Black Body	SSI [CIE A] Tungsten	SSI [CIE D65] Daylight
CRI	CRI R9	TM30 R _f	TM30 R _g	TLCI	CQS	x	Y	Δuv	SSIt	SSId
95.2	75.7	91.9	100.6	94	91.4	0.329	0.330	-0.0042	39	70

CIE 1931

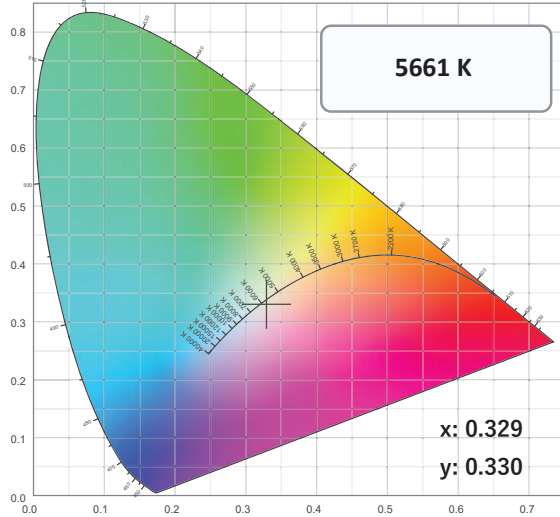

CIE 1931 ZOOMED

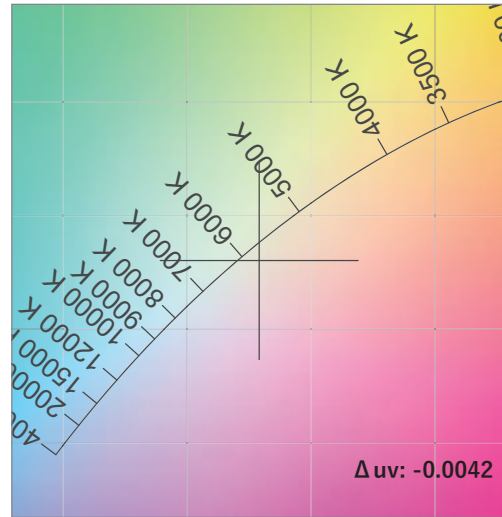

CRI: 95.2 (R1-R8)

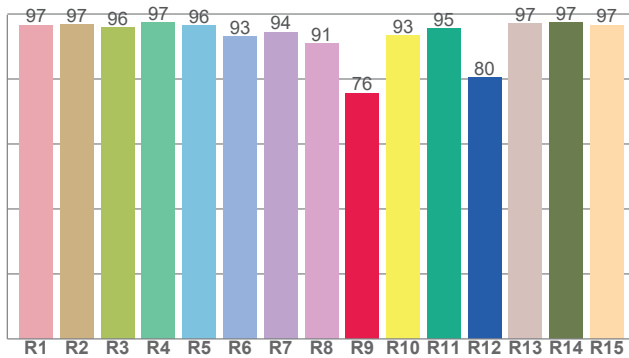

Spectral Power Distribution (SPD)

Dominant Wavelength 605 nm

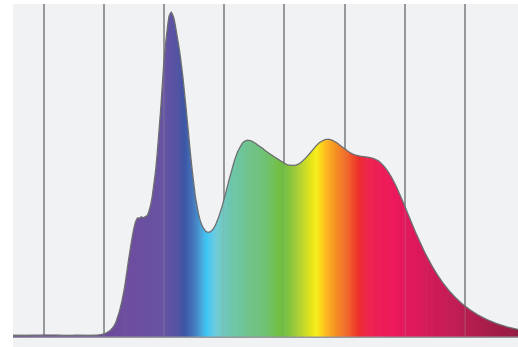

SSI Spectral Variance Graph- Tungsten

SSI [CIE A] 39

Spectral variance

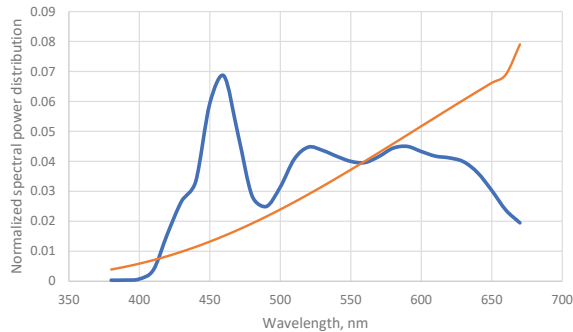

— Test Source — CIE Illuminant A - Tungsten

SSI Spectral Variance Graph- Daylight

SSI [CIE D65] 70

Spectral variance

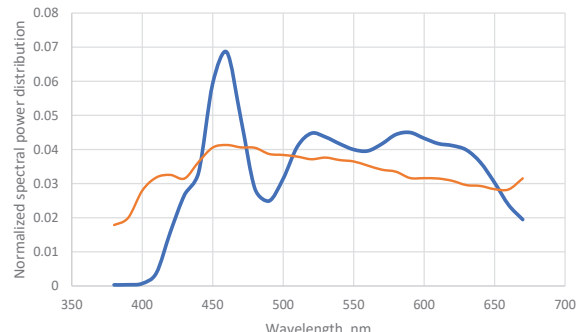

— Test Source — CIE Illuminant D65 - Daylight

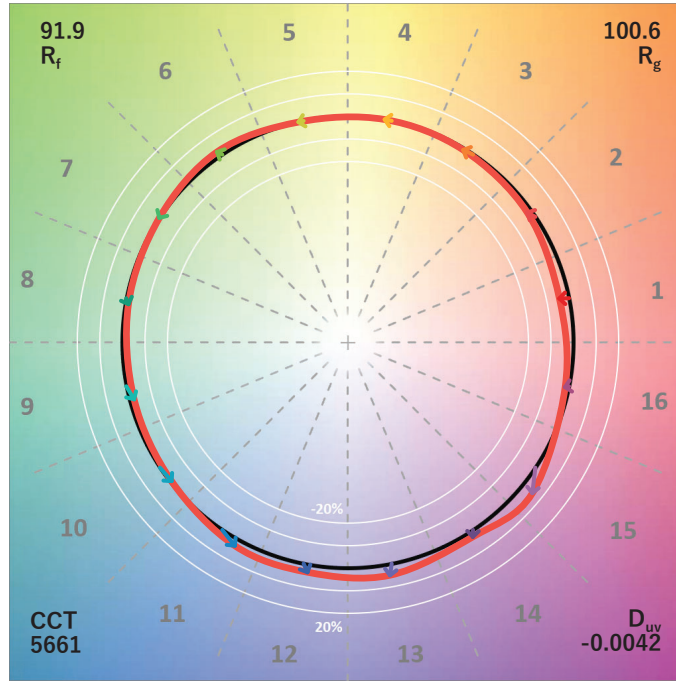

TM30-18 R_f Values per Hue Bin

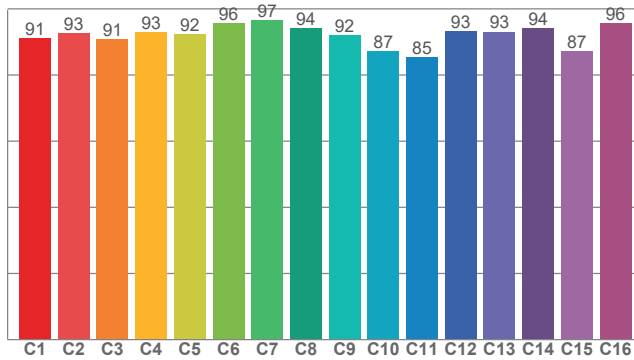

TM30 Chroma Shift per Hue Bin

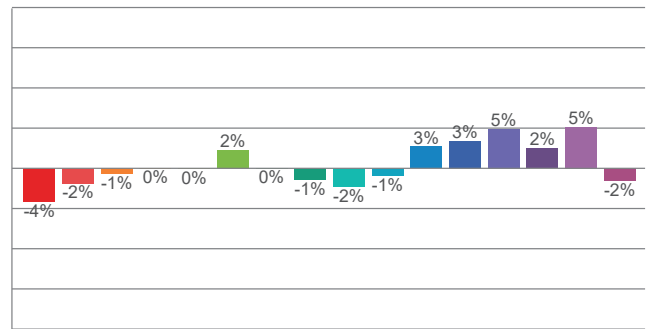

TM30-18 R_f Values per Reference Color (CES)

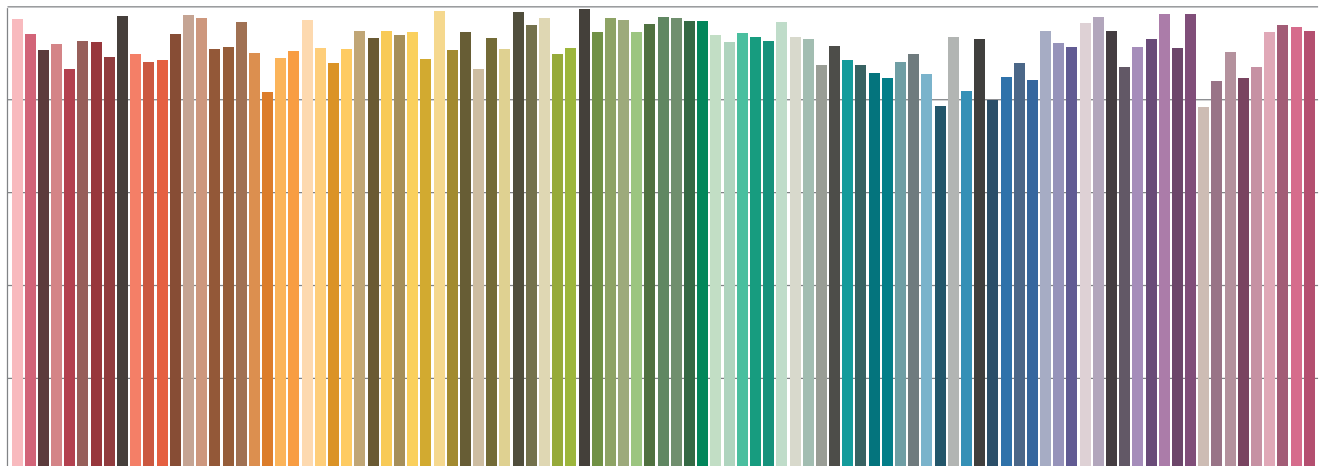

Color Temperature: 2266K

Accuracy Metric Overview

Color Rendering Index	Color Rendering Index, R9 (Red Component)	TM-30 Color Fidelity	TM-30 Color Gamut	Television Lighting Consistency Index	Color Quality Scale	Color Coordinate- CIE 1931	Color Coordinate- CIE 1931	Deviation from Black Body	SSI [CIE A] Tungsten	SSI [CIE D65] Daylight
CRI	CRI R9	TM30 R _f	TM30 R _g	TLCI	CQS	x	Y	Δuv	SSIt	SSId
85.6	78.0	86.7	102.7	62	83.1	0.495	0.409	-0.0021	72	22

CIE 1931

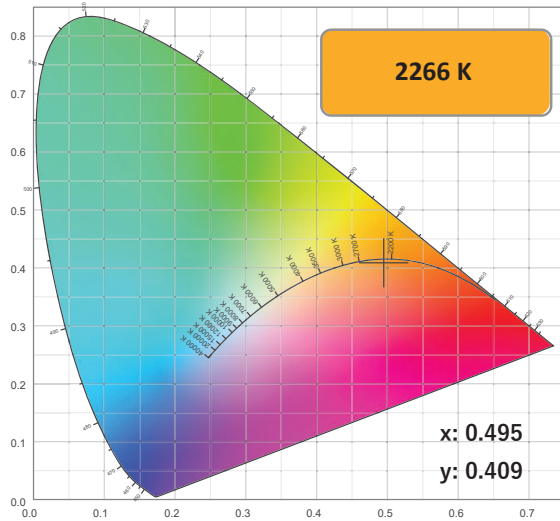

CIE 1931 ZOOMED

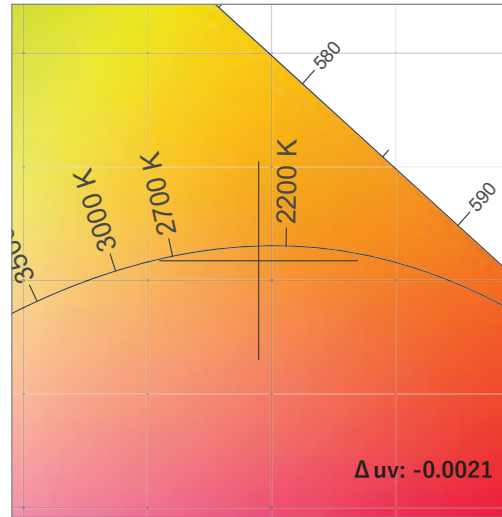

CRI: 85.6 (R1-R8)

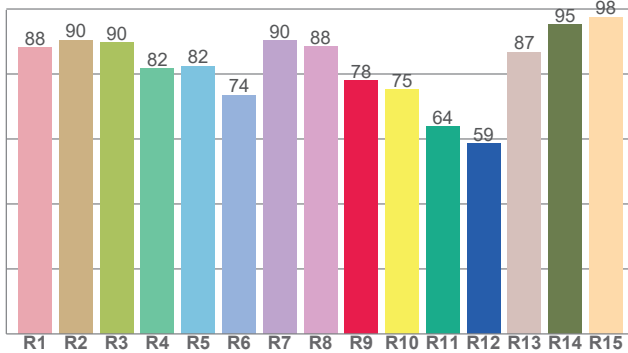

Spectral Power Distribution (SPD)

Dominant Wavelength 588 nm

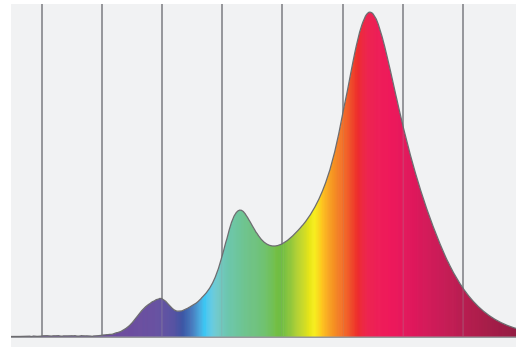

SSI Spectral Variance Graph- Tungsten

SSI [CIE A] 72

Spectral variance

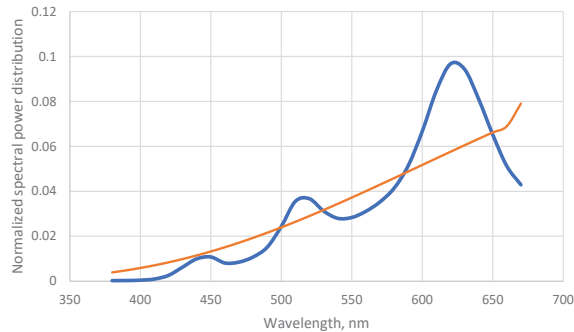

— Test Source — CIE Illuminant A - Tungsten

SSI Spectral Variance Graph- Daylight

SSI [CIE D65] 22

Spectral variance

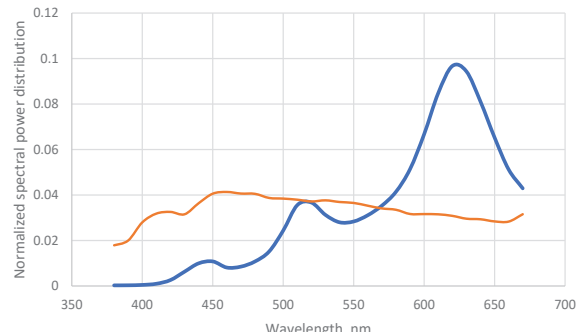

— Test Source — CIE Illuminant D65 - Daylight

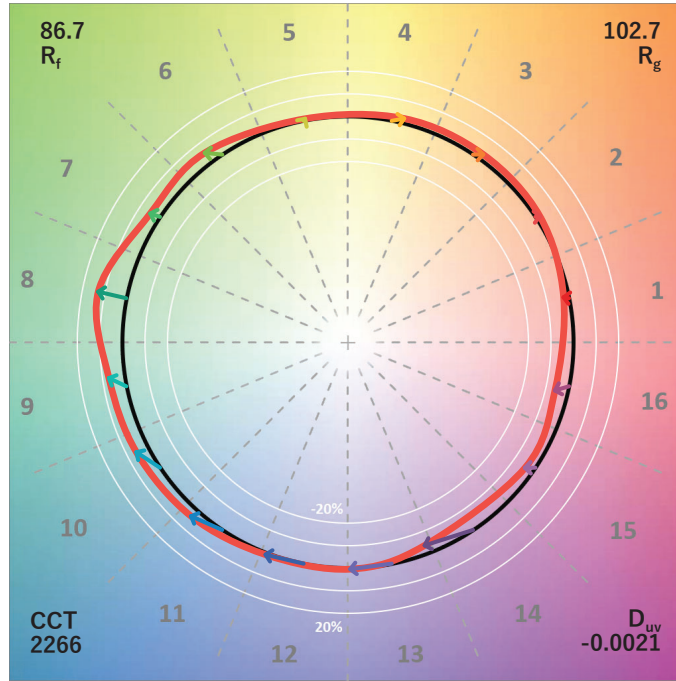

TM30-18 R_f Values per Hue Bin

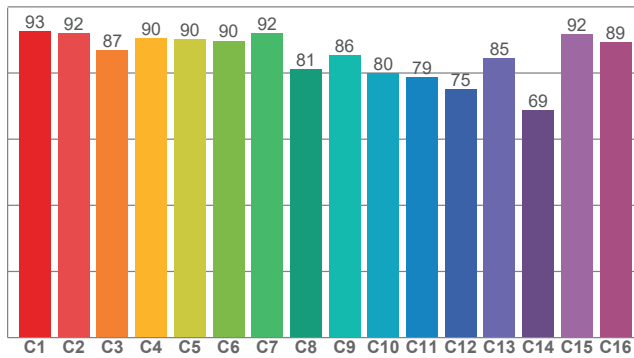

TM30 Chroma Shift per Hue Bin

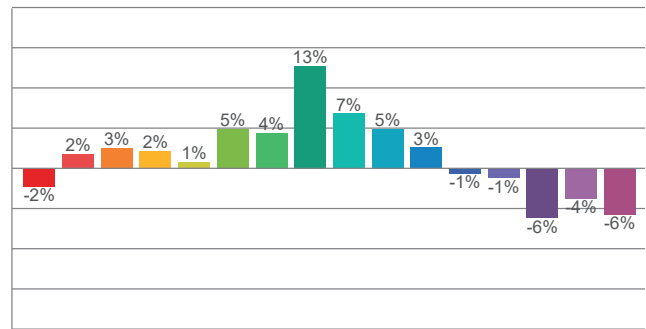

TM30-18 R_f Values per Reference Color (CES)

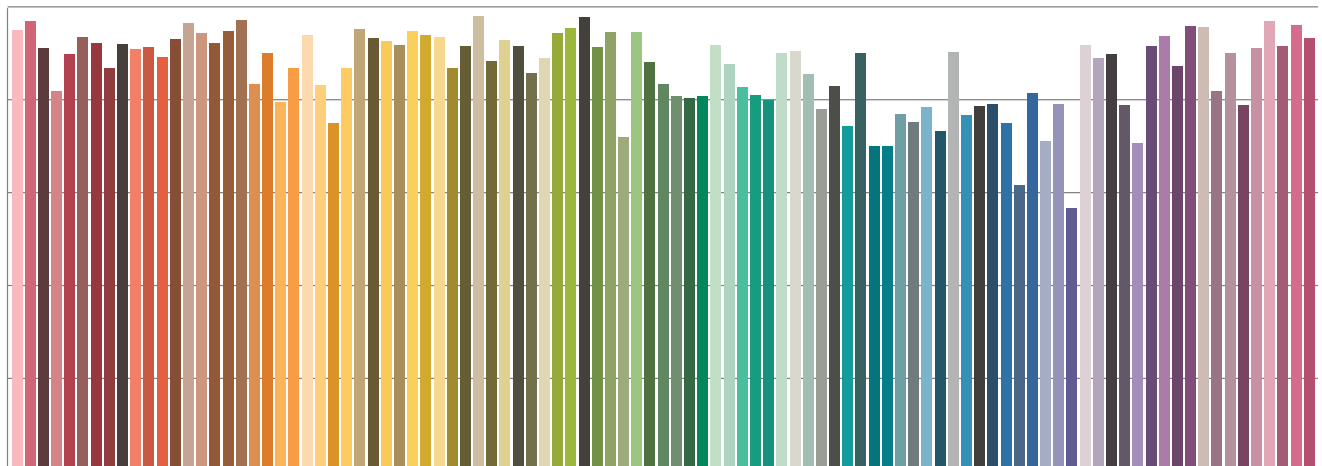

Color Temperature: 2255K

Accuracy Metric Overview

Color Rendering Index	Color Rendering Index, R9 (Red Component)	TM-30 Color Fidelity	TM-30 Color Gamut	Television Lighting Consistency Index	Color Quality Scale	Color Coordinate- CIE 1931	Color Coordinate- CIE 1931	Deviation from Black Body	SSI [CIE A] Tungsten	SSI [CIE D65] Daylight
CRI	CRI R9	TM30 R _f	TM30 R _g	TLCI	CQS	x	Y	Δuv	SSIt	SSId
83.3	91.7	84.7	104.4	57	81.5	0.492	0.402	-0.0042	75	23

CIE 1931

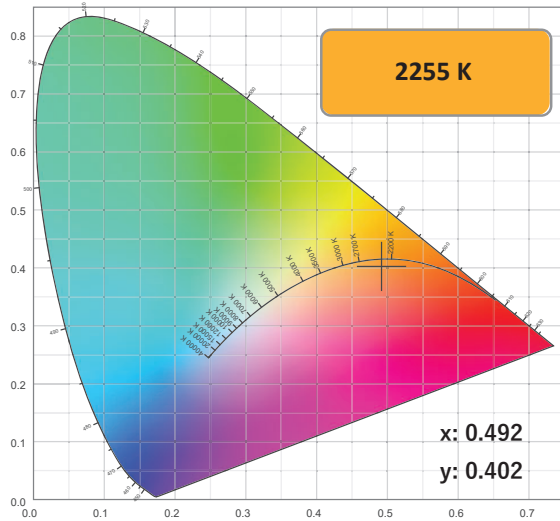

CIE 1931 ZOOMED

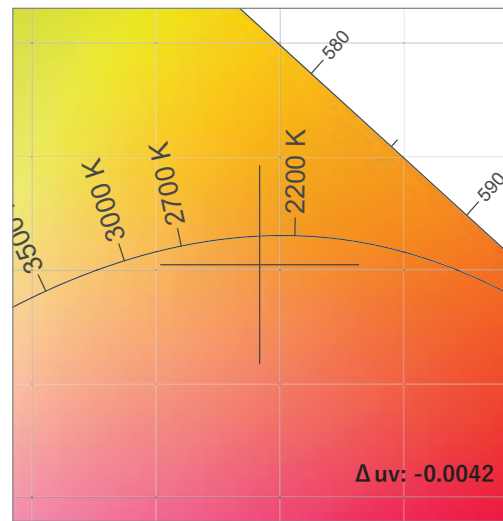

CRI: 83.3 (R1-R8)

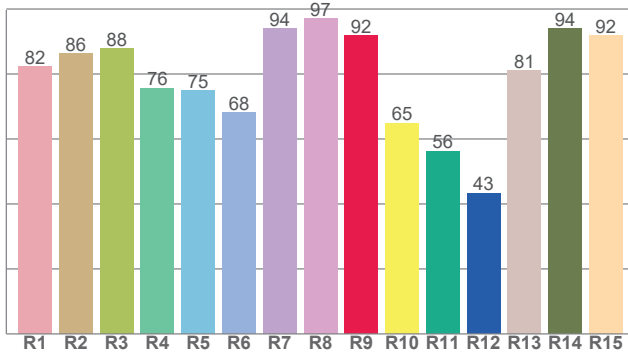

Spectral Power Distribution (SPD)

Dominant Wavelength 589 nm

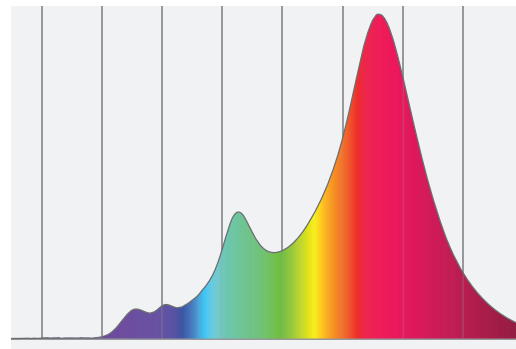

SSI Spectral Variance Graph- Tungsten

SSI [CIE A] 75

Spectral variance

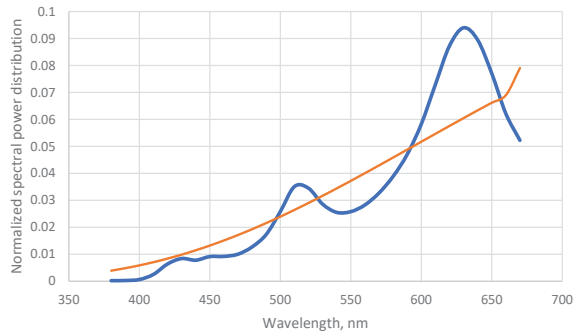

— Test Source — CIE Illuminant A - Tungsten

SSI Spectral Variance Graph- Daylight

SSI [CIE D65] 23

Spectral variance

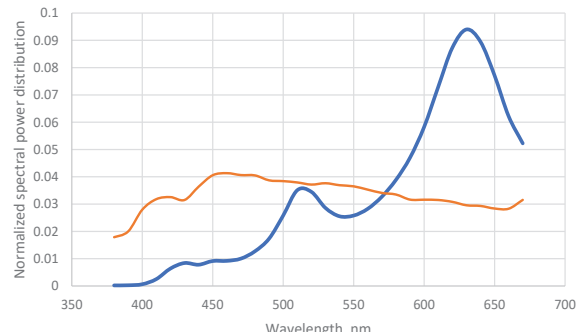

— Test Source — CIE Illuminant D65 - Daylight

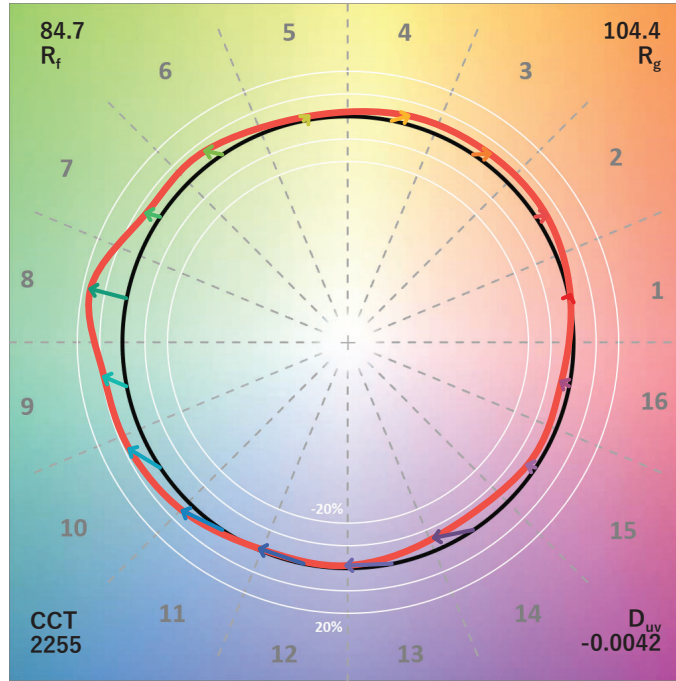

TM30-18 R_f Values per Hue Bin

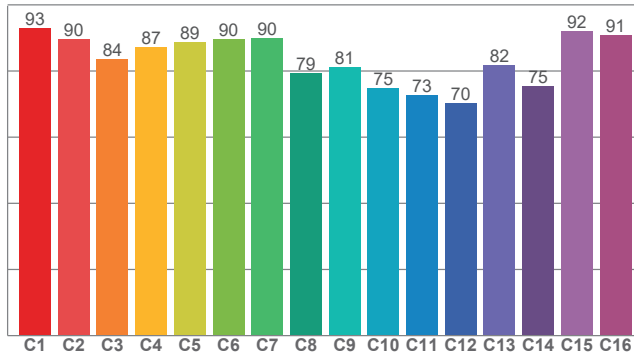

TM30 Chroma Shift per Hue Bin

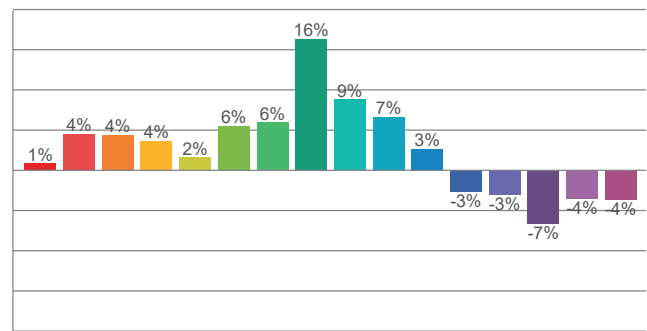

TM30-18 R_f Values per Reference Color (CES)

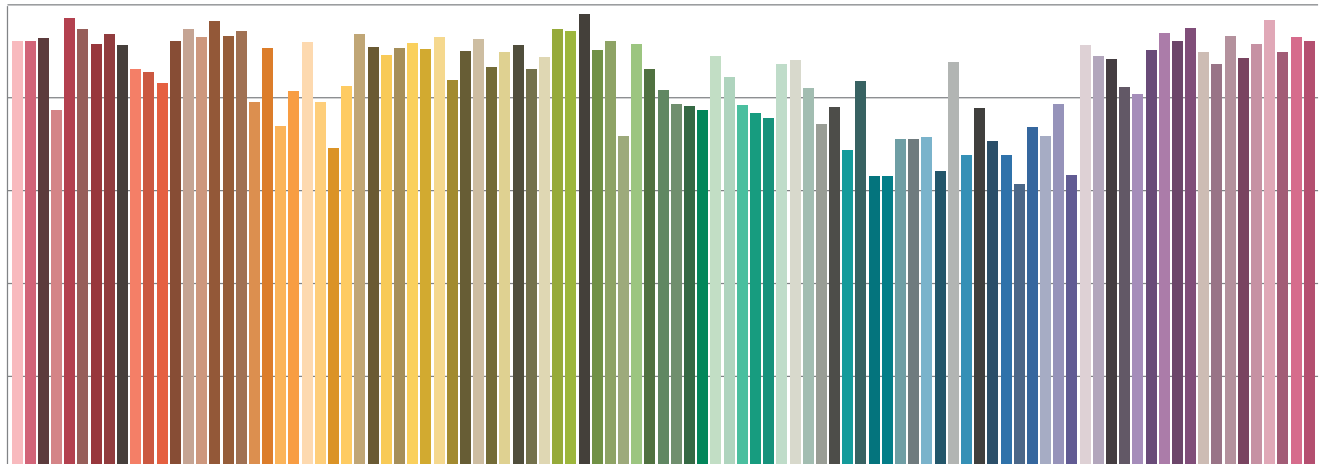

Measurements

Total Lumen Output: 2754 lm
 Peak Intensity: 42121 cd
 Efficacy: 5 Lumen/Watt
 Power: 530 W
 Voltage: 117 V, Current: 4.53 A

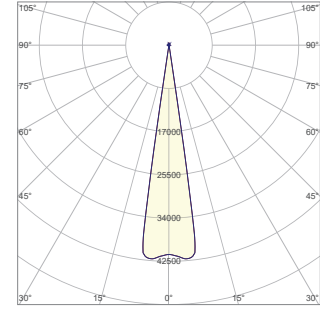

Spectral Power Distribution

Dominant Wavelength 475 nm

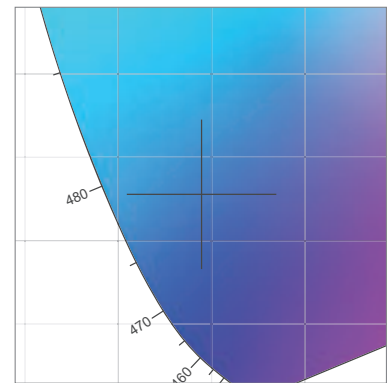
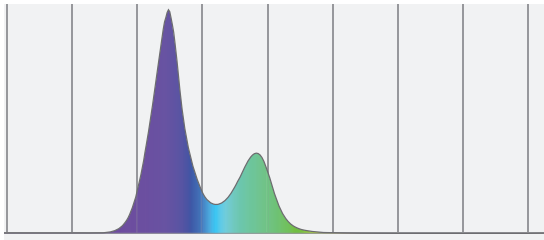

Dominant Wavelength	Color Coordinate CIE 1931	Color Coordinate CIE1931	Color Coordinate CIE 1964	Color Coordinate CIE 1964
nm	x	y	u	v
475	0.145	0.128	0.136	0.181

15 m
4.3 m

20 m
5.8 m

10 m
2.9 m

15 m
4.3 m

20 m
5.8 m

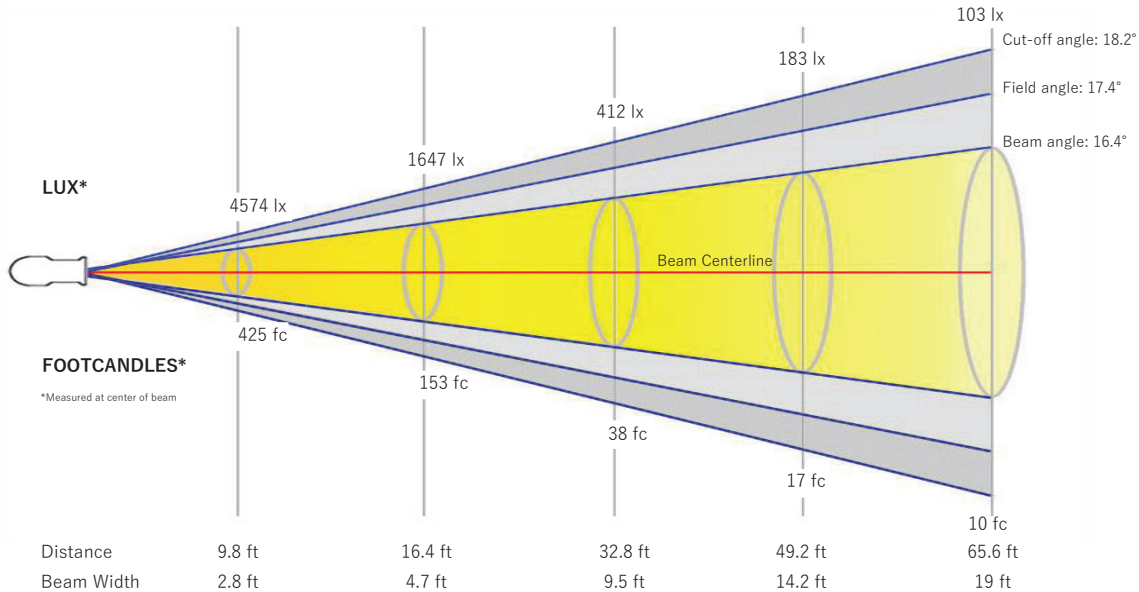

Beam Intensities from 1-20m

M	1	2	3	4	5	6	7	8	9	10	11	12	13	14	15	16	17	18	19	20
FT	3.3	6.6	9.8	13.1	16.4	19.7	23	26.2	29.5	32.8	36.1	39.4	42.7	45.9	49.2	52.5	55.8	59.1	62.3	65.6
LX	41163	10291	4574	2573	1647	1143	840	643	508	412	340	286	244	210	183	161	142	127	114	103
FC	3824.2	956	424.9	239	153	106.2	78	59.8	47.2	38.2	31.6	26.6	22.6	19.5	17	14.9	13.2	11.8	10.6	9.6

Measurements

Total Lumen Output: 976 lm
 Peak Intensity: 14804 cd
 Efficacy: 2 Lumen/Watt
 Power: 530 W
 Voltage: 117 V, Current: 4.53 A

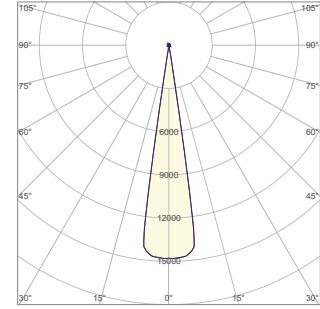
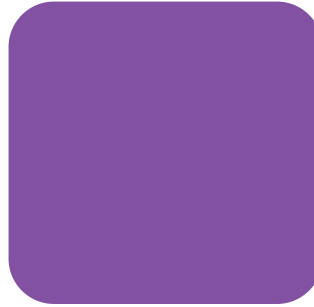

Spectral Power Distribution

Dominant Wavelength 562 nm

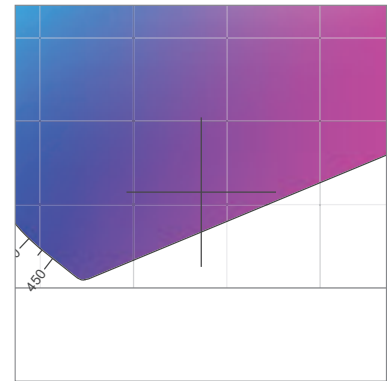
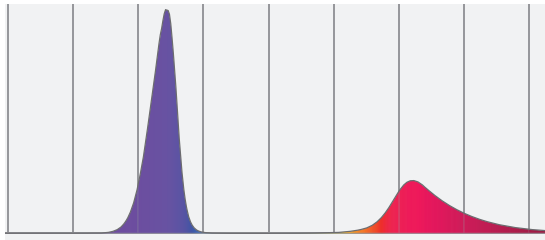

Dominant Wavelength	Color Coordinate CIE 1931	Color Coordinate CIE1931	Color Coordinate CIE 1964	Color Coordinate CIE 1964
nm	x	y	u	v
562	0.236	0.057	0.294	0.107

15 m
4.4 m

20 m
5.8 m

10 m
2.9 m

15 m
4.4 m

20 m
5.8 m

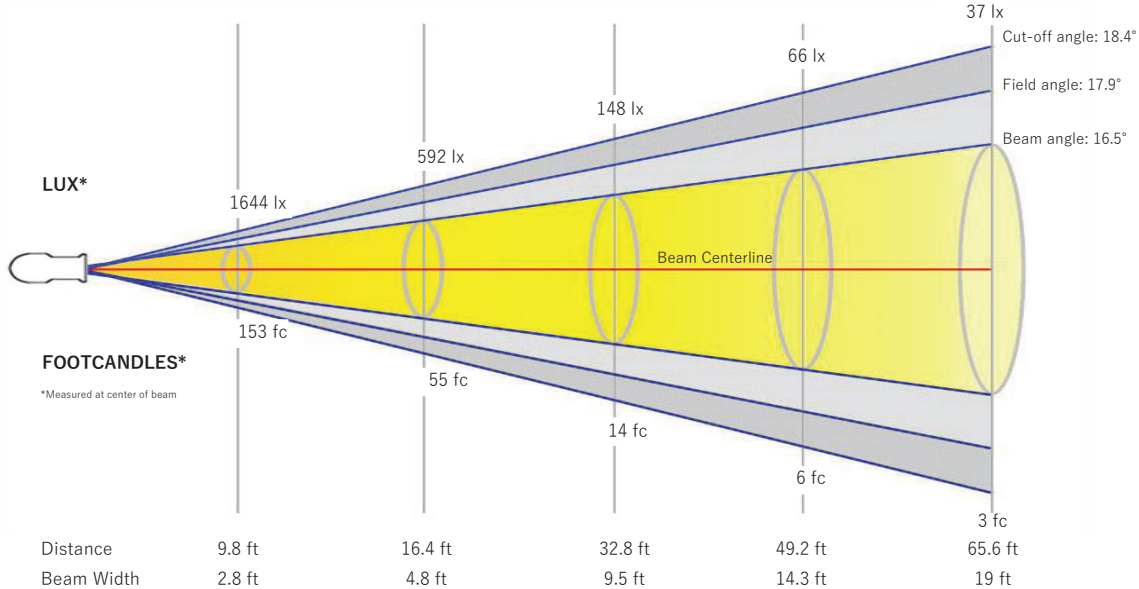

Beam Intensities from 1-20m

M	1	2	3	4	5	6	7	8	9	10	11	12	13	14	15	16	17	18	19	20
FT	3.3	6.6	9.8	13.1	16.4	19.7	23	26.2	29.5	32.8	36.1	39.4	42.7	45.9	49.2	52.5	55.8	59.1	62.3	65.6
LX	14792	3698	1644	924	592	411	302	231	183	148	122	103	88	75	66	58	51	46	41	37
FC	1374.2	343.5	152.7	85.9	55	38.2	28	21.5	17	13.7	11.4	9.5	8.1	7	6.1	5.4	4.8	4.2	3.8	3.4

Measurements

Total Lumen Output: 11849 lm
 Peak Intensity: 180651 cd
 Efficacy: 23 Lumen/Watt
 Power: 525 W
 Voltage: 117 V, Current: 4.49 A

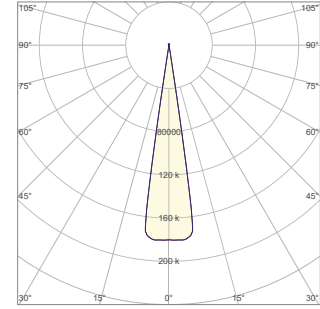

Spectral Power Distribution

Dominant Wavelength 576 nm

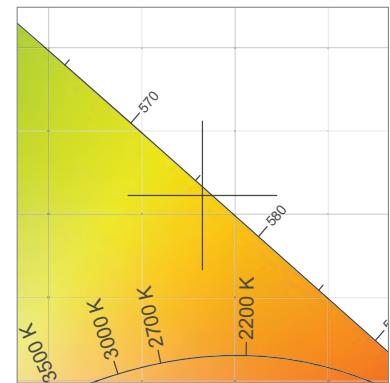
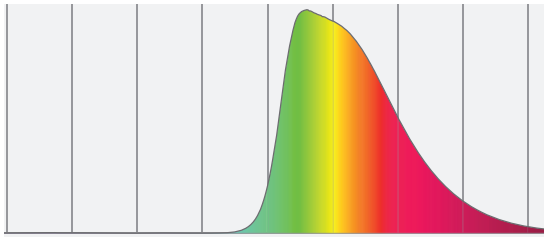

Dominant Wavelength	Color Coordinate CIE 1931	Color Coordinate CIE1931	Color Coordinate CIE 1964	Color Coordinate CIE 1964
nm	x	y	u	v
576	0.482	0.511	0.236	0.375

15 m
4.4 m

20 m
5.8 m

10 m
2.9 m

15 m
4.4 m

20 m
5.8 m

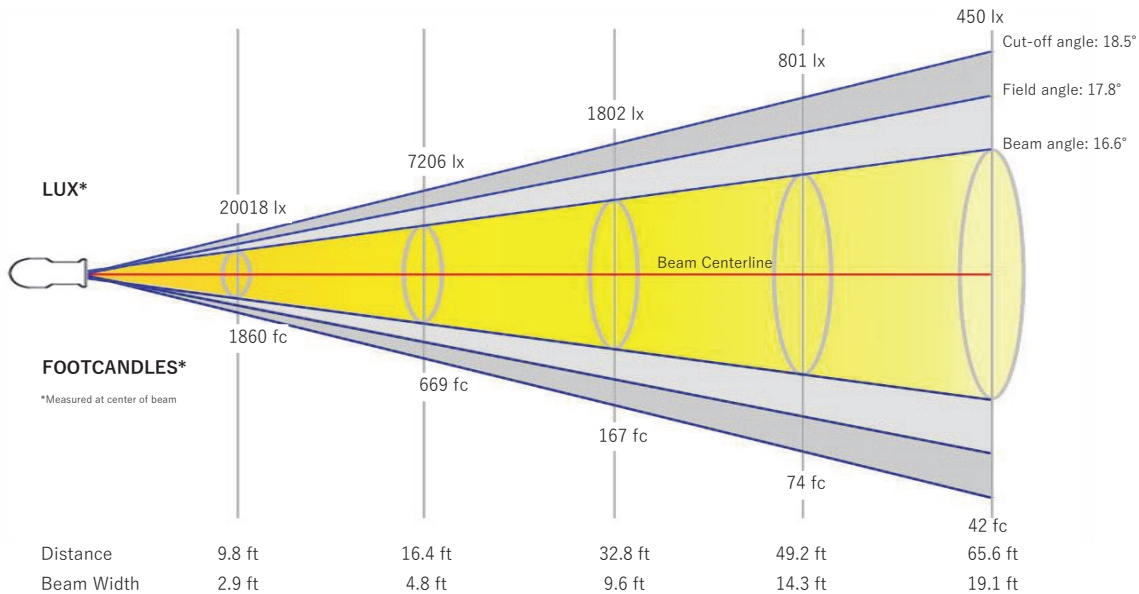

Beam Intensities from 1-20m

M	1	2	3	4	5	6	7	8	9	10	11	12	13	14	15	16	17	18	19	20
FT	3.3	6.6	9.8	13.1	16.4	19.7	23	26.2	29.5	32.8	36.1	39.4	42.7	45.9	49.2	52.5	55.8	59.1	62.3	65.6
LX	180160	45040	20018	11260	7206	5004	3677	2815	2224	1802	1489	1251	1066	919	801	704	623	556	499	450
FC	16737.5	4184.4	1859.7	1046.1	669.5	464.9	341.6	261.5	206.6	167.4	138.3	116.2	99	85.4	74.4	65.4	57.9	51.7	46.4	41.8