

# **ELATION®**

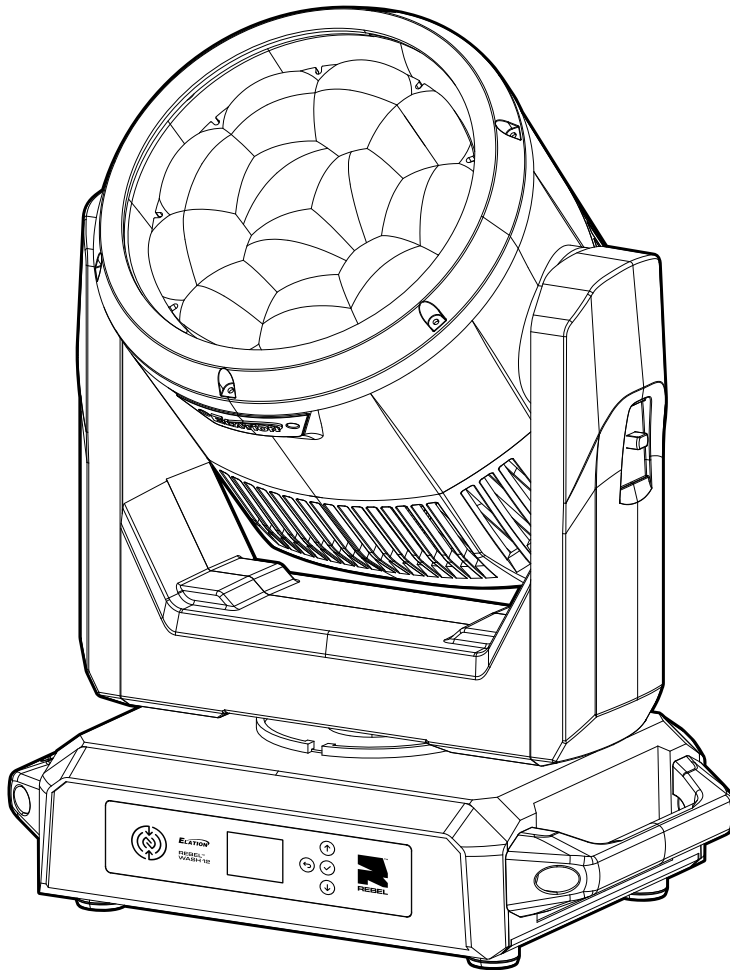

**REBEL™ WASH 12**  
**user manual**

©2026 ELATION PROFESSIONAL all rights reserved. Information, specifications, diagrams, images, and instructions herein are subject to change without notice. ELATION PROFESSIONAL logo and identifying product names and numbers herein are trademarks of ELATION PROFESSIONAL. Copyright protection claimed includes all forms and matters of copyrightable materials and information now allowed by statutory or judicial law or hereinafter granted. Product names used in this document may be trademarks or registered trademarks of their respective companies and are hereby acknowledged. All non-ELATION brands and product names are trademarks or registered trademarks of their respective companies.

**ELATION PROFESSIONAL** and all affiliated companies hereby disclaim any and all liabilities for property, equipment, building, and electrical damages, injuries to any persons, and direct or indirect economic loss associated with the use or reliance of any information contained within this document, and/or as a result of the improper, unsafe, insufficient and negligent assembly, installation, rigging, and operation of this product.

**Elation Professional USA | 6122 S. Eastern Ave. | Los Angeles, CA. 90040**

323-582-3322 | [www.elationlighting.com](http://www.elationlighting.com) | [info@elationlighting.com](mailto:info@elationlighting.com)

**Elation Professional B.V. | Junostraat 2 | 6468 EW Kerkrade, The Netherlands**

+31 45 546 85 66 | [www.elationlighting.eu](http://www.elationlighting.eu) | [info@elationlighting.eu](mailto:info@elationlighting.eu)

**Elation Professional Mexico | AV Santa Ana 30 | Parque Industrial Lerma, Lerma, Mexico 52000**

+52 (728) 282-7070

## DOCUMENT VERSION



Due to additional product features and/or enhancements, an updated version of this document may be available online. Please scan the QR Code with your mobile device or visit [www.elationlighting.com](http://www.elationlighting.com) for the latest revision/update of this manual, before installation and/or programming.

Date	Document Version	SoftwareVersion ≥	DMX Channel Modes	Notes
02/05/2026	1.0	1.0.0	21/28/68	Initial Release
03/17/2026	1.1	N/C	No Change	Updated Specifications

# CONTENTS

<b>Introduction</b>	<b>4</b>
<b>IP65 Rated</b>	<b>5</b>
<b>Safety Guidelines</b>	<b>6</b>
<b>Overview</b>	<b>8</b>
<b>Custom Logo Plate Installation</b>	<b>9</b>
<b>Torque Settings for Screws</b>	<b>10</b>
<b>IP Test Parameters</b>	<b>11</b>
<b>Installation Guidelines</b>	<b>12</b>
<b>Aria Setup and Guidelines</b>	<b>17</b>
<b>System Menu</b>	<b>20</b>
<b>Sun Protection Mode   Hibernation Mode</b>	<b>22</b>
<b>Fan Modes and Low Noise Operation</b>	<b>23</b>
<b>Dimmer Modes   Dimmer Curves</b>	<b>24</b>
<b>DMX Traits</b>	<b>25</b>
<b>DMX Traits: RGBL Pixels</b>	<b>31</b>
<b>Color Temperature</b>	<b>32</b>
<b>Virtual Colors (Color Swatch)</b>	<b>33</b>
<b>Remote Device Management (RDM)</b>	<b>34</b>
<b>Maintenance Guidelines</b>	<b>35</b>
<b>Error Codes</b>	<b>36</b>
<b>Software Updates</b>	<b>37</b>
<b>Specifications</b>	<b>38</b>
<b>Dimensional Drawings</b>	<b>39</b>
<b>Optional Accessories   FCC Statement</b>	<b>40</b>

# GENERAL INFORMATION

## FOR PROFESSIONAL USE ONLY

### INTRODUCTION

Please read and understand the instructions in this manual carefully and thoroughly before attempting to operate this device. These instructions contain important safety and use information.

### COOLING

After usage, the lamp may be switched off, but the fixture should remain connected to power in order to allow the fan time to cool down the fixture.

### UNPACKING

Every device has been thoroughly tested and has been shipped in perfect operating condition. Carefully check the shipping carton for damage that may have occurred during shipping. If the carton is damaged, carefully inspect the device for damage, and be sure all accessories necessary to install and operate the device have arrived intact. In the event damage has been found or parts are missing, please contact our customer support team for further instructions. Please do not return this device to your dealer without first contacting customer support. Please do not discard the shipping carton in the trash. Please recycle whenever possible.

### BOX CONTENTS

Omega Brackets (x2)  
Safety Cable  
IP65 Rated Locking Power Cable

### CUSTOMER SUPPORT

Contact ELATION Service for any product related service and support needs. Also visit [forums.elationlighting.com](https://forums.elationlighting.com) with questions, comments or suggestions.

**ELATION SERVICE USA - Monday - Friday 8:00am to 4:30pm PST**  
**323-582-3322 | [support@elationlighting.com](mailto:support@elationlighting.com)**

**ELATION SERVICE EUROPE - Monday - Friday 08:30 to 17:00 CET**  
**+31 45 546 85 63 | [support@elationlighting.eu](mailto:support@elationlighting.eu)**

**REPLACEMENT PARTS** please visit [parts.elationlighting.com](https://parts.elationlighting.com)

### LIMITED WARRANTY

For up-to-date warranty information regarding your device, please visit Elation's warranty information page online or scan the QR codes below.



USA: <https://www.elationlighting.com/warranty-information>



EU: [https://www.elationlighting.eu/terms\\_and\\_conditions](https://www.elationlighting.eu/terms_and_conditions)

It is strongly recommended to power the fixture down completely when not in use. Doing so will reduce wear on the fixture due to sustained or extended operational periods, thereby maximizing its operational lifespan.

# IP65 RATED

The **International Protection (IP)** rating system is commonly expressed as “**IP**” (Ingress Protection) followed by two numbers (i.e. IP65), where the numbers define the degree of protection. The first digit (Foreign Bodies Protection) indicates the extent of protection against particles entering the fixture, and the second digit (Water Protection) indicates the extent of protection against water entering the fixture. An **IP65** rated lighting fixture is designed and tested to protect against the ingress of dust (**6**), and low-pressure water jets from any direction (**5**).

**NOTE: THIS FIXTURE IS INTENDED FOR TEMPORARY OUTDOOR USE ONLY!**

**Maritime/Seaside Environment Installations:** A maritime/seaside environment is adjacent to the sea and caustic to electronics through exposure to atomized salt water and humidity, whereas a coastal environment extends 5 miles inland.



**NOT suitable for maritime/seaside environment installations. Installing this fixture in a maritime/seaside environment may cause corrosion and/or excessive wear to the interior and/or exterior components of the fixture. Damages and/or performance issues resulting from installation in a maritime/seaside environment will void the manufacturer’s warranty, and will NOT be subject to any warranty claims and/or repairs.**

Maritime installations require additional preparation, and additional service intervals may be needed given the maritime use. In general, IP ratings presuppose freshwater conditions VS maritime conditions, which are typically more “caustic” to IP fixtures (both internally and externally). A duty-cycle may also be needed when units are not in use. During times of high humidity and colder temperatures, condensation may occur internally so the fixture may require a duty-cycle to bring it up to running temperature, allowing any accumulation of moisture to be expelled via the vent valve. Recommendations can change based on installation environmental circumstances. A waterproof dome or similar device is recommended for use in permanent outdoor installations. When using a dome, refer to manufacturer recommendations for duty-cycle.

**NOTE: NOT ALL FEATURES LISTED ARE AVAILABLE ON ALL FIXTURES; THE FOLLOWING INSTRUCTIONS MAY NOT APPLY. CONTACT SUPPORT FOR ADDITIONAL DETAILS.**

**Exterior Maintenance:** Inspect the exterior every 30-days. The unit must be powered off/disconnected. The chassis should be inspected for any signs of contaminants. Inspect optics to determine if the lens is obstructed, then clean optics and chassis accordingly. Based on initial finding, schedule maintenance accordingly, keeping in mind that exterior maintenance will be required. Even if the luminaires are NOT in use, maintenance will still be needed given its location (exterior use). The use of a durable type of wax on the chassis is recommended since it will help prevent contaminant build up. Inspect both power and data lines for any signs of contaminants or corrosion. Periodically reapplying di-electric grease, especially in coastal environments. If any signs of corrosion/contaminants are present, clean thoroughly, and/or replace connectors, then reapply di-electric grease. Typically, this should be done annually, or any time an opportunity presents itself. As a preventive measure, annual replacement of both vent valves is recommended. The vent valve membrane can become contaminated and/or clogged causing improper venting of humidity within the luminaire. Inspect all mounting hardware as a precaution.

**Interior Maintenance:** Inspect the interior every 30-days. The unit must be powered off/disconnected.

- Inspect zoom/focus mechanism, clean optics, lubricate linear bearings (Krytox oil) as needed, inspect belts for wear
- Inspect all rotating effect wheels, manually rotate them, note any resistance
- Inspect all remaining rotating belts for any wear
- Inspect all fans, clean as needed, check rotation, check connections
- Inspect CMY module, manually move flags and check for signs of resistance, and if needed, clean guide rods first, then reapply a thin layer of grease (moly lube)
- Clean interior with low-volume compressed air, then clean optics prior to reassembly of head covers

Although the base has limited moving parts, the pan belt should also be inspected for wear. Remember to always perform an IP test anytime a cover is removed.

There is no specific time frame regarding the routine replacement of parts such as belts/stepper motors, PCBs, or LEDs. These items should only be replaced on an as needed bases, except for cooling fans, which should be replaced once the luminaries reach 10,000-hours. This is a prophylactic measure intended to keep the unit running as cool as possible, insuring proper function of all internal components. A complete service breakdown is available, please contact [service@elationlighting.com](mailto:service@elationlighting.com) for any needed parts or manuals.

# SAFETY GUIDELINES

This fixture is a sophisticated piece of electronic equipment. To guarantee a smooth operation, it is important to follow all instructions and guidelines in this manual. Elation Professional is not responsible for injury and/or damages resulting from the misuse of this fixture due to the disregard of the information printed in this manual. Only qualified and/or certified personnel should perform installation of this fixture and only the original rigging parts (omega brackets) included with this fixture should be used for installation. Any modifications to the fixture and/or the included mounting hardware will void the original manufacturer's warranty and increase the risk of damage and/or personal injury.



**PROTECTION CLASS 1 - FIXTURE MUST BE PROPERLY GROUNDED.**



**THERE ARE NO USER SERVICEABLE PARTS INSIDE THIS UNIT.  
DO NOT ATTEMPT ANY REPAIRS YOURSELF; DOING SO WILL VOID YOUR  
MANUFACTURER'S WARRANTY. DAMAGES RESULTING FROM MODIFICATIONS  
TO THIS FIXTURE AND/OR THE DISREGARD OF SAFETY INSTRUCTIONS AND  
GUIDELINES IN THIS MANUAL VOID THE MANUFACTURE'S WARRANTY AND ARE  
NOT SUBJECT TO ANY WARRANTY CLAIMS AND/OR REPAIRS.**



**DO NOT PLUG FIXTURE INTO A DIMMER PACK!  
NEVER OPEN THIS FIXTURE WHILE IN USE!  
UNPLUG POWER BEFORE SERVICING FIXTURE!  
NEVER TOUCH FIXTURE DURING OPERATION, AS IT MAY BE HOT!  
KEEP FLAMMABLE MATERIALS AWAY FROM FIXTURE!**

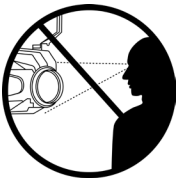

**NEVER LOOK DIRECTLY INTO THE LIGHT SOURCE!  
RETINA INJURY RISK - MAY INDUCE BLINDNESS!  
SENSITIVE PERSONS MAY SUFFER AN EPILEPTIC SHOCK!**



**MINIMUM DISTANCE TO OBJECTS/SURFACES MUST BE 1.6 FEET (.5 METERS)  
MINIMUM DISTANCE OF FLAMMABLE MATERIALS 1.6 FEET (0.5 METER)  
MINIMUM DISTANCE TO LIGHTING OBJECTS 1.6 FEET (0.5 METER)  
MINIMUM/MAXIMUM AMBIENT TEMPERATURE -4°F-113°F (-20°C-45°C)**

1. The light source in this luminaire should only be replaced by the manufacturer, their authorized service agent, or a similarly qualified individual.
2. Position the luminaire so that prolonged staring into it from a distance closer than 3.8 meters is unlikely.
3. This luminaire is designed exclusively for professional use.

# SAFETY GUIDELINES

**DONOT TOUCH** the fixture housing during operation. Turn OFF the power and allow approximately 15 minutes for the fixture to cool down before serving.

**DO NOT** shake fixture, avoid brute force when installing and/or operating fixture.

**DO NOT** operate fixture if the power cord is frayed, crimped, damaged and/or if any of the power cord connectors are damaged and do not insert into the fixture securely with ease. NEVER force a power cord connector into the fixture. If the power cord or any of its connectors are damaged, replace it immediately with a new one of similar power rating.

**DO NOT** block any air ventilation slots.

All fan and air inlets must remain clean and never blocked.

Allow approx. 1.6' (.5m) between fixture and other devices or a wall for proper cooling.

Always disconnect fixture from main power source before performing any type of service and/or cleaning procedure. Only handle the power cord by the plug end, never pull out the plug by tugging the wire portion of the cord.

During the initial operation of this fixture, a light smoke or smell may emit from the interior of the fixture. This is a normal process and is caused by excess paint in the interior of the casing burning off from the heat associated with the lamp and will decrease gradually over time.

Consistent operational breaks will ensure fixture will function properly for many years.

**ONLY** use the original packaging and materials to transport the fixture in for service.

# OVERVIEW

NFC Access Point    LCD Display    Back Button    Up Button    Enter Button

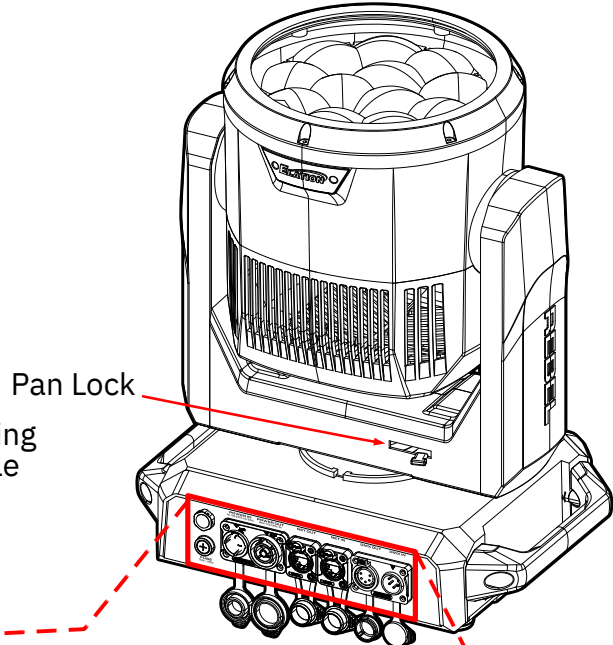
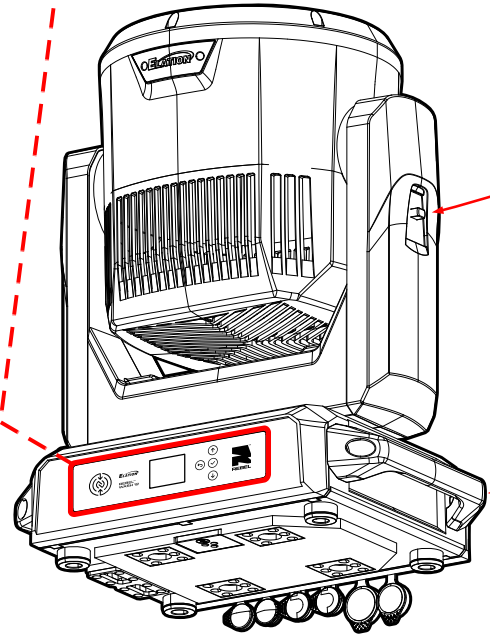
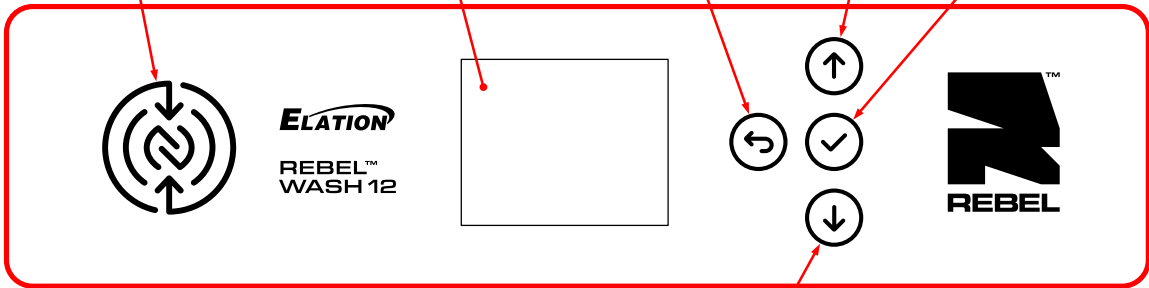

Valve

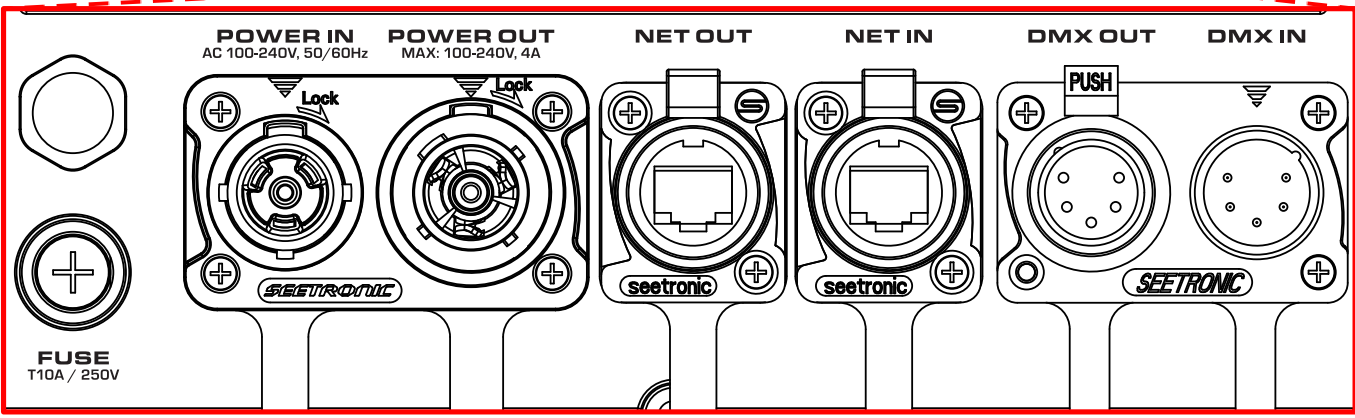

Fuse                      Power In/Out                      Net Out/In                      DMX Out /In

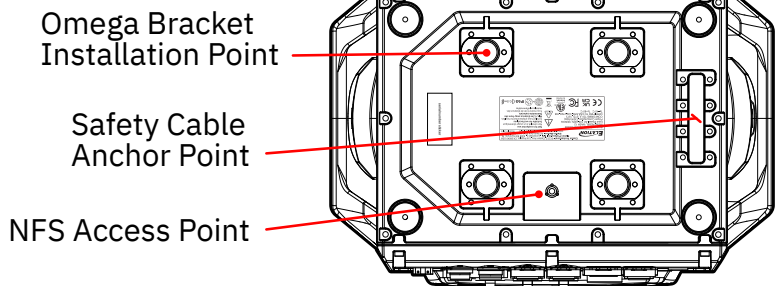

# CUSTOM LOGO PLATE INSTALLATION

To install a Logo Plate, ensure the fixture is powered off and disconnected.

Locate and remove the existing Elation Logo Plate using a hex driver by unscrewing the two holding screws. Using the existing mounting screws, align the screw holes of the new badge with the mounting holes of the fixture.

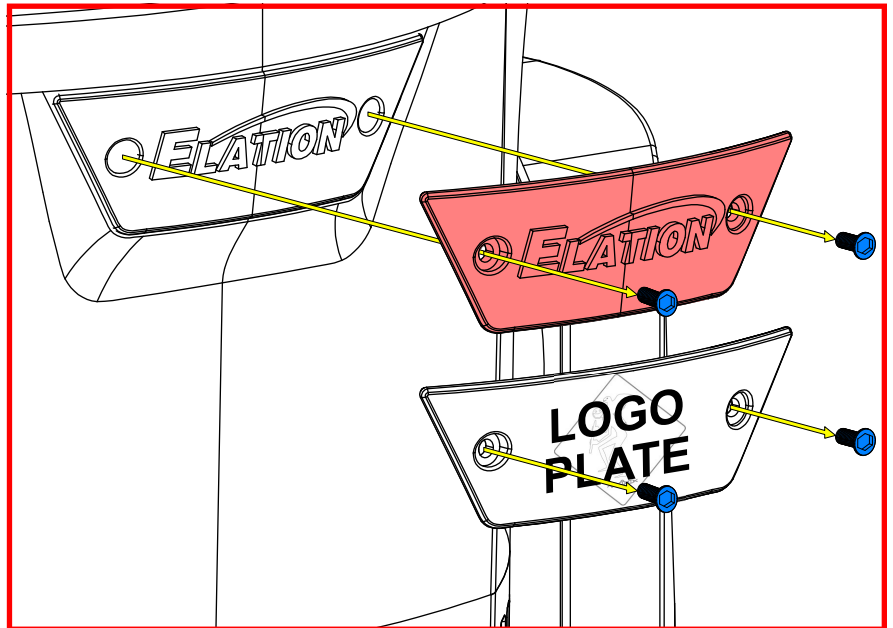
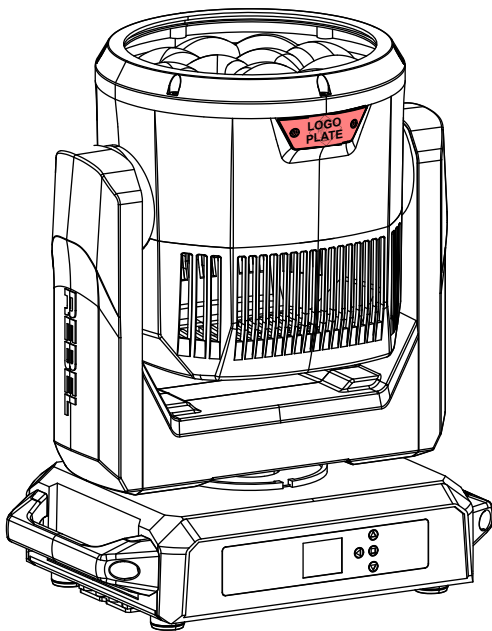
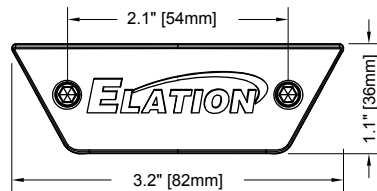
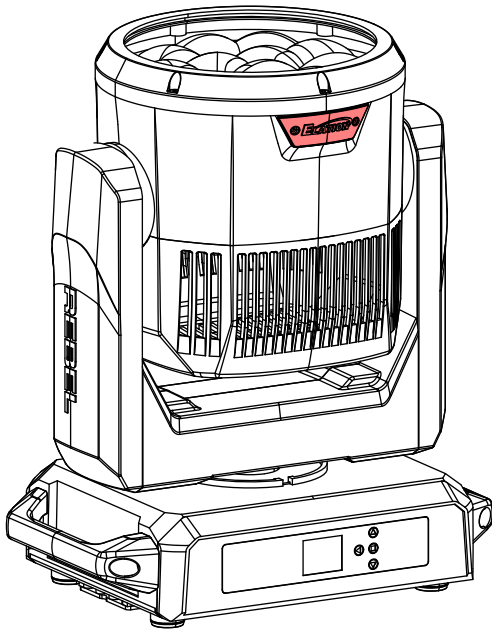

Gently screw the new Logo Plate into place, making sure it is flush and straight. Do not overtighten to prevent damage to the badge or the fixture.

After installation, check that the Logo Plate does not interfere with any moving parts of the fixture. Once everything looks good, reconnect the power, turn on the fixture, and observe its operation to ensure the badge installation has not affected functionality. Periodically check the badge for tightness, particularly after transportation or if the fixture is frequently moved, to avoid it becoming loose over time.

# TORQUE SETTINGS FOR SCREWS



PANEL SCREWS MUST BE TIGHTENED WITH A TORQUE WRENCH ACCORDING TO THE TORQUE SPECIFICATION DESCRIBED BELOW.



CAUTION! DO NOT OVER TORQUE SCREWS AS THIS CAN CAUSE LEAKAGE ISSUES! TO CONFIRM THE IP65 INTEGRITY AFTER A PROCEDURE REQUIRING DISASSEMBLY/REASSEMBLY, TEST THE FIXTURE USING THE IP TESTER. CONTACT ELATION SERVICE FOR MORE DETAILS.



CAUTION! THE USE OF PROTECTIVE GLOVES AND SAFETY GOGGLES IS STRONGLY RECOMMENDED WHILE PERFORMING THE IP PRESSURE TEST! AVOID PLACING YOUR FACE, EYES, HANDS, ETC IN CLOSE PROXIMITY TO THE FIXTURE'S LENS WHILE PERFORMING THE TEST!

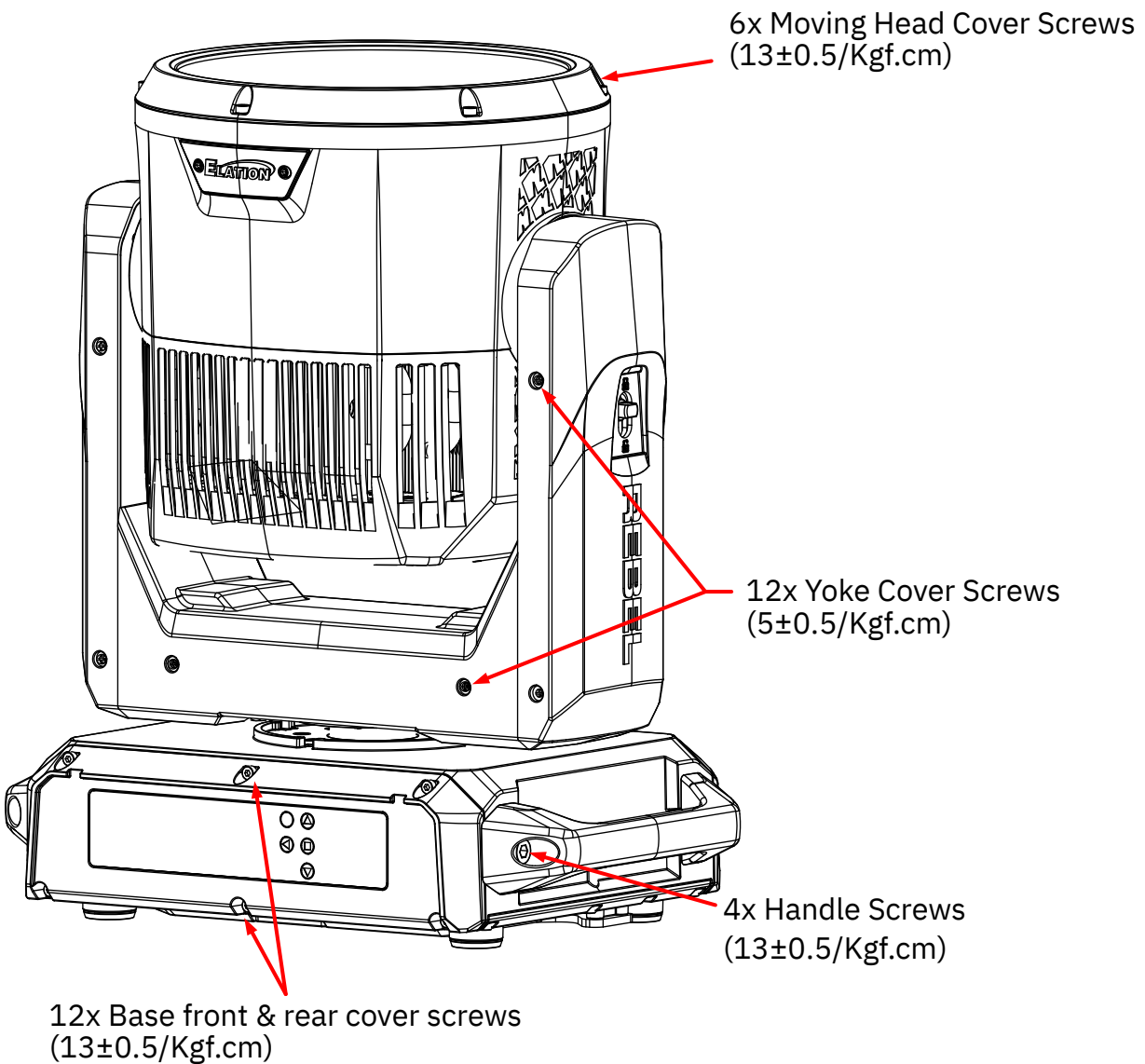

# IP TEST PARAMETERS

Following any repair or maintenance procedure that requires disassembly of the fixture, use Elation's IP Tester to confirm the IP integrity of the fixture. Please contact Elation Service for information regarding the Elation IP Tester, or visit the product information page online at: <https://www.elationlighting.com/ip-tester>



**CAUTION! THE USE OF PROTECTIVE GLOVES AND SAFETY GOGGLES IS STRONGLY RECOMMENDED WHILE PERFORMING THE IP PRESSURE TEST! AVOID PLACING YOUR FACE, EYES, HANDS, ETC IN PROXIMITY TO THE LENS OF THE FIXTURE WHILE PERFORMING THE TEST!**

**DE-HUMIDIFICATION:** IP65 fixtures operating in high-humidity environments may experience residual fogging or condensation. Such fogging will not affect the fixture, and can be removed using the following procedure: position the unit with the air valve pointing upwards, then open the air valve and run the unit for 1-2 hours after reaching operating temperature. Then, while the fixture is still hot, re-install the air valve and allow the unit to cool down. Please note: this procedure should be performed in a dry, climate-controlled environment. Avoid additional fogging by drying the fixture completely before placing into a road case.

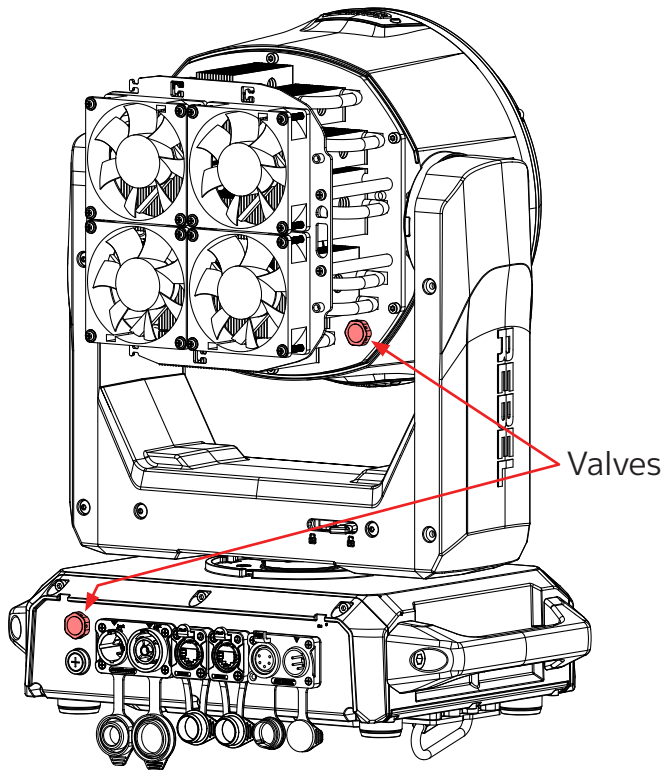

IP PRESSURE TESTING PARAMETERS			
Test Type	Low Pressure Limit	High Pressure Limit	Hold Time
Vacuum Test	-4.35psi (-30.00 KPa)	-5.08 psi (-35.00 KPa)	10s
Pressure Test	3.62 psi (25.00 KPa)	4.35 psi (30.00 KPa)	10s

## FIXTURE DISASSEMBLY

The following points should be observed after performing any maintenance procedure that requires disassembly of the unit:

- After the unit has been reassembled, open the valve and allow the unit to run for approximately 2 hours in order to dry out any moisture that has been trapped inside the fixture. The process should continue until indicated humidity drops below 15% for the head and 30% for the base.
- Once this has been achieved, the light can be switched off, but the unit should remain connected to power so that the cooling fan can cool down the unit. Please note that allowing cool down time should **ALWAYS** be done after lamp operation.
- Some units may require partial disassembly in order to gain access to the valve. Please contact Elation service for information regarding the location and access procedure for the valve on your specific unit model.

# INSTALLATION GUIDELINES



## **FLAMMABLE MATERIAL WARNING**

Keep fixture minimum 5.0 feet (1.5m) away from flammable materials and/or pyrotechnics.



## **ELECTRICAL CONNECTIONS**

A qualified electrician should be used for all electrical connections and/or installations.



**USE CAUTION WHEN POWER LINKING OTHER MODEL FIXTURES AS THE POWER CONSUMPTION OF OTHER MODEL FIXTURES MAY EXCEED THE MAX POWER OUTPUT ON THIS FIXTURE. CHECK SILK SCREEN FOR MAX AMPS.**



**MINIMUM DISTANCE TO OBJECTS/SURFACES  
MUST BE 1.6 FOOT (0.5 METERS)**



**MINIMUM DISTANCE OF FLAMMABLE MATERIALS  
FROM THE SURFACE 1.6 FEET (0.5 METER)**



**MAXIMUM AMBIENT TEMPERATURE 113° F (45°C)**



**DO NOT INSTALL THE FIXTURE IF YOU ARE NOT QUALIFIED TO DO SO!**

Fixture **MUST** be installed following all local, national, and country commercial electrical and construction codes and regulations.

Before rigging/mounting the fixture to any metal truss/structure or placing the fixture on any surface, a professional equipment installer **MUST** be consulted to determine if the metal truss/structure or surface is properly certified to safely hold the combined weight of the fixture, clamps, cables, and accessories.

Overhead rigging requires extensive experience, including, amongst others, calculating working load limits, installation material being used, and periodic safety inspection of all installation material and the fixture. If you lack these qualifications, do not attempt the installation yourself. Improper installation can result in bodily injury.

Fixture ambient operating temperature range is **-4° to 113°F. (-20° to 45°C)**

Do not use the fixture under or above this temperature.

Fixture should be installed in areas outside walking paths, seating areas, or away from areas where unauthorized personnel might reach the fixture by hand.

**NEVER** stand directly below the fixture when rigging, removing or servicing.

Overhead fixture installation must always be secured with a secondary safety attachment, such as an appropriately rated safety cable.

Allow approximately 10 minutes for the fixture to cool down before servicing.

# INSTALLATION GUIDELINES

## OMEGA BRACKETS WITH CLAMP INSTALLATION

When mounting the fixture to a truss, be sure to secure an appropriately rated professional grade rigging clamp to the included **Omega Brackets** using an M10 screw fitted through the center hole of the **Omega Brackets**. Insert the Omega Brackets into the matching holes on the bottom of the fixture. Secure the Omega Brackets to the fixture by turning each quick-lock fastener ¼ turn clockwise; making sure the fastener is completely locked. Omega Brackets can be installed into the fixture base as illustrated below.

### \*SAFETY CABLE\*

**ALWAYS ATTACH AN APPROPRIATELY RATED SAFETY CABLE WHENEVER INSTALLING THIS FIXTURE IN A SUSPENDED ENVIRONMENT TO ENSURE THE FIXTURE WILL NOT FALL IF THE CLAMP FAILS.**

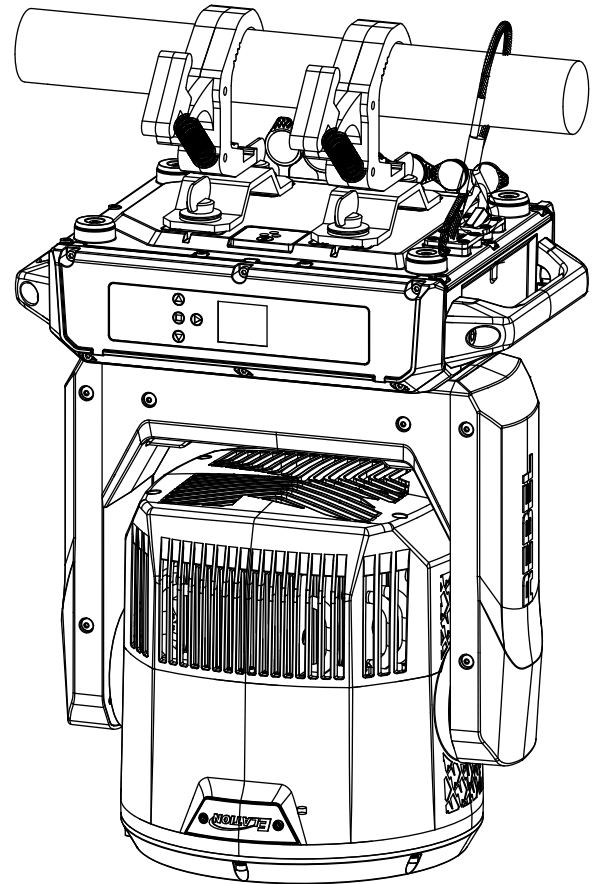
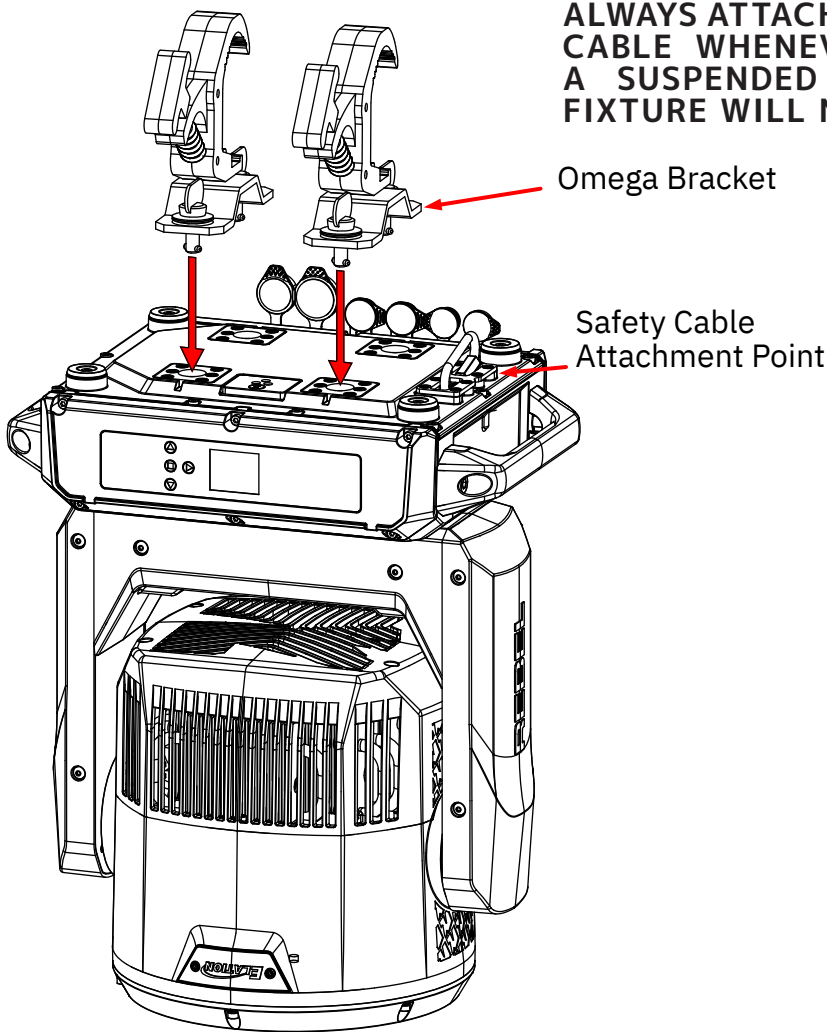

## RIGGING

Overhead rigging requires extensive experience, including among others, calculating working load limits, installation material being used, and periodic safety inspection of all installation material and the fixture. If you lack these qualifications, do not attempt the installation yourself. Improper installation can result in bodily injury. The fixture provides a built-in rigging point for a **SAFETY CABLE** (not included). Be sure to only use one of the designated rigging point for the safety cable and never secure a safety cable to a carrying handle. Connect the safety cable to the attachment point and route it around the truss.

# INSTALLATION GUIDELINES

## FIXTURE INSTALLATION

The Elation Rebel Wash 12 is fully operational in three different mounting positions, hanging upside-down, mounted sideways on trussing, or set on a flat level surface. Be sure this fixture is kept at least (1.6' (0.5m) away from any flammable materials (decoration etc.). Always use and install the supplied safety cable as a safety measure to prevent accidental damage and/or injury in the event the clamp fails. Never use the carrying handles for secondary attachment.

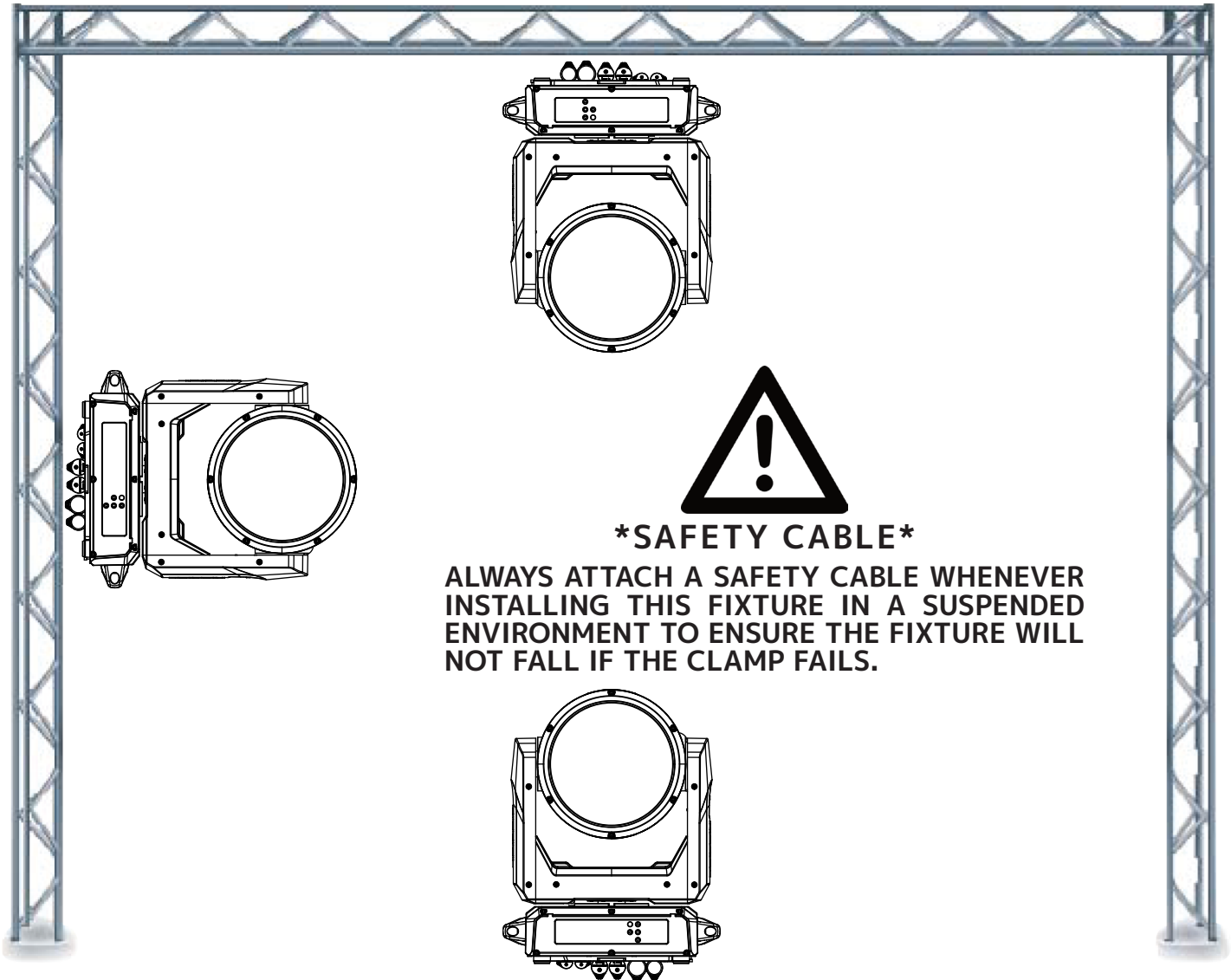

## ART-NET | sACN CONNECTION

When connecting fixture to a network switch to control multiple devices, a **Gigabit Ethernet Switch** that supports **IGMP (Internet Group Management Protocol)** is required. Using a **Gigabit Ethernet Switch** that does not support **IGMP** can cause erratic behavior of all connected devices to the switch. Click link below for more information about IGMP.

[https://en.wikipedia.org/wiki/Internet\\_Group\\_Management\\_Protocol](https://en.wikipedia.org/wiki/Internet_Group_Management_Protocol)



**FALLING FIXTURES CAN CAUSE SEVERE INJURY OR SERIOUS EQUIPMENT DAMAGE! FOR THIS REASON, FIXTURES SHOULD BE INSTALLED AND INSPECTED ONLY BY QUALIFIED PERSONNEL. DO NOT INSTALL THE UNIT IF YOU LACK THE QUALIFICATIONS TO DO SO, OR IF YOU HAVE DOUBTS ABOUT THE SAFETY AND SECURITY OF THE INSTALLATION SETUP OR LOCATION!**



**ALWAYS ATTACH A SAFETY CABLE WHENEVER INSTALLING THIS FIXTURE IN A SUSPENDED ENVIRONMENT TO ENSURE THE FIXTURE WILL NOT FALL IF THE CLAMP FAILS.**

# INSTALLATION GUIDELINES

## ART-NET | sACN CONNECTION

When connecting fixture to a network switch to control multiple devices, a Gigabit Ethernet Switch that supports IGMP (Internet Group Management Protocol) is required. Using a Gigabit Ethernet Switch that does not support IGMP can cause erratic behavior of all connected devices to the switch. Click link below for more information about IGMP.

[https://en.wikipedia.org/wiki/Internet\\_Group\\_Management\\_Protocol](https://en.wikipedia.org/wiki/Internet_Group_Management_Protocol)

## POWER AND DATA CABLES



**ENSURE ALL CONNECTIONS AND END-CAPS ARE PROPERLY SEALED WITH DIELECTRIC GREASE (AVAILABLE AT MOST ELECTRICAL SUPPLIERS) TO PREVENT WATER CORROSION AND/OR ELECTRICAL SHORT CIRCUIT.**



**TO MAINTAIN THE IP65 RATING INTEGRITY OF THE FIXTURE, ALL CABLES MUST BE RUN TOWARDS THE GROUND TO PREVENT WATER ACCUMULATION AROUND THE CONNECTIONS.**

### SYSTEM MENU LCD DISPLAY

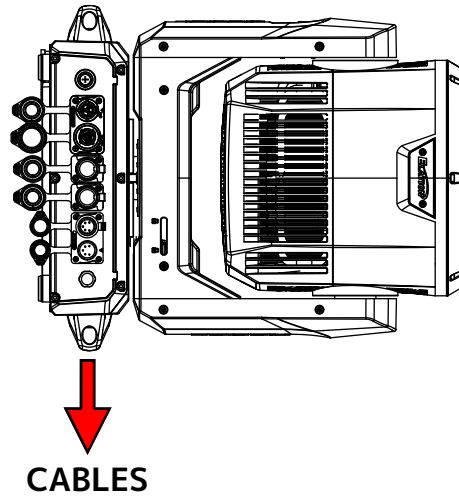
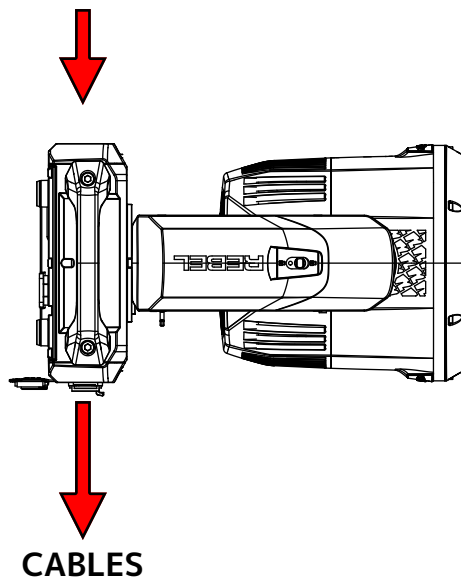

# INSTALLATION GUIDELINES

## POTENTIAL INTERNAL FIXTURE DAMAGE FROM EXTERNAL SOURCES OF LIGHT BEAMS

External sources of light beams from direct sunlight, lighting moving head fixtures, and lasers, which are focused directly towards the exterior housing and/or penetrate the front lens opening of ELATION lighting fixtures, can cause severe internal damage including burning to optics, dichroic color filters, glass and metal gobos, prisms, animation wheels, frost filters, iris, shutters, motors, belts, wiring, discharge lamps, and LEDs.

This issue is not specific only to ELATION lighting fixtures, it is a common issue with lighting fixtures from all manufacturers. Although there is no true way to fully prevent this issue from happening, the guidelines below can prevent any potential damage from occurring if followed. Contact ELATION Service for more details.

**DO NOT EXPOSE THE FIXTURE AND/OR FRONT LENS OPENING TO LIGHT BEAMS FROM DIRECT SUNLIGHT, OTHER LIGHTING MOVING HEAD FIXTURES, AND LASERS WHILE UNPACKING, INSTALLATION, USE, AND EXTENDED IDLE TIMES OUTDOORS. DO NOT FOCUS A LIGHT BEAM FROM ONE LIGHTING FIXTURE DIRECTLY TOWARDS ANOTHER.**

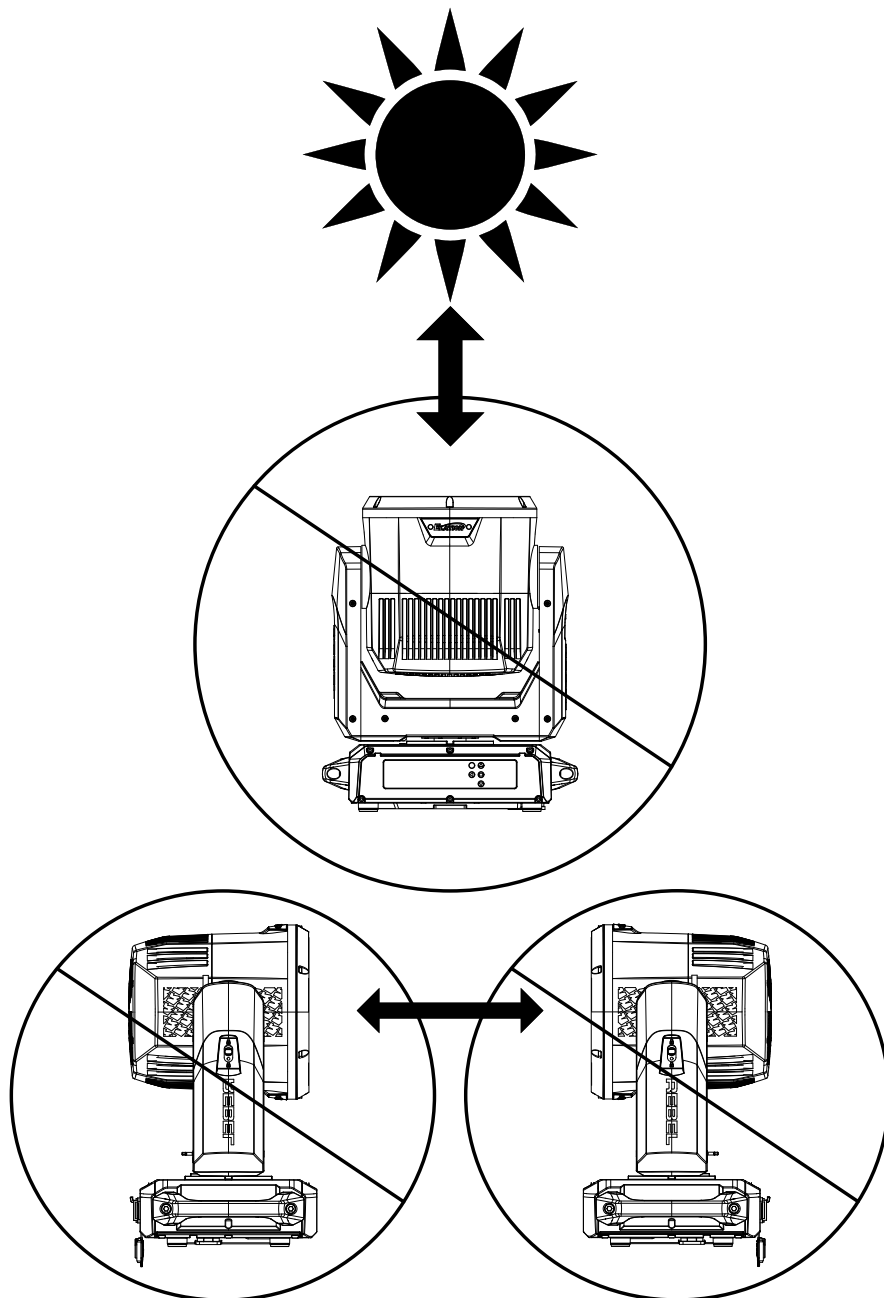

# ARIA SETUP AND GUIDELINES

## 2.4GHZ Versus Sub-Gig (GHz) Frequencies:

Sub-GHz frequencies provide superior reliability and range compared to higher frequencies, making them perfect for consistent communication across vast distances or in difficult conditions. Devices operating in the sub-GHz range, which refers to frequencies below 1 GHz, can transmit signals over significant distances and can penetrate physical barriers such as walls and buildings more effectively. Additionally, these frequencies experience less interference compared to those in the heavily congested 2.4-GHz band, which is commonly used by wireless devices.

In the United States, the 900 MHz band is a versatile frequency range that is utilized by various services, with the FCC overseeing its allocation and regulation.

In the European Union, the 868 MHz frequency is designated by ETSI as the Sub-Gig frequency.

In summary, if an application demands high data rates and more bandwidth in urban or densely populated areas where interference management is feasible, the 2.4 GHz frequency is a suitable choice. On the other hand, for applications requiring long-range communication and better obstacle penetration, particularly in rural or industrial settings with fewer regulatory constraints, a sub-GHz frequency (<1 GHz) is a better option.

## Installation Recommendations:

With the many factors that affect and/or interrupt a wireless signal such as walls, glass, metal, objects, and people, it is highly recommended to:

- Install devices a minimum of 9.8 ft. (3m) above audiences and/or ground level where practical.
- Adjust the wireless antenna in a vertical upright position
- Position devices in direct line of sight of the controlling device

Careful planning and testing of the selected installation location is critical to ensure optimum and reliable wireless operation.

**9.8 ft (3m)  
Above Ground**

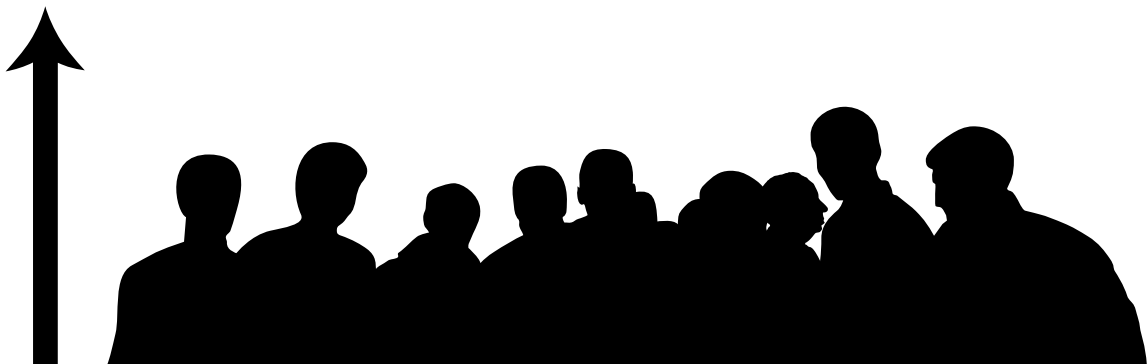

# ARIA SETUP AND GUIDELINES

## GENERAL INFORMATION

The Aria Bluetooth app has the ability to connect wirelessly to any device that has Aria wireless DMX installed and has Bluetooth enabled.

Before installing the fixture in a remote location, double check that the fixture's main power is switched on, and that the Bluetooth function has been enabled in the fixture's system menu. Certain fixtures may have Bluetooth disabled by default. If this function is disabled, then the fixture cannot be configured remotely using the Aria app, and will have to be configured directly from the fixture's control screen.

Additionally, the user should consider setting the fixture's No DMX setting to "Hold Last". This will allow the fixture to continue running using the current settings, even if the Aria app device moves out of range, the app is closed, or the signal is otherwise interrupted, minimizing disruption in the operation of the fixtures.

## LEGACY DEVICES

Please note that legacy connected devices, such as those using Wifly, E-Fly, or Magfly, are not compatible with this app. For such legacy devices, the use of a bridge is recommended, as the bridge can communicate with these devices via its SM220 protocol.

The Aria X2 BLE app is currently available from the Apple app store.

## FIXTURE IDENTIFICATION

Aria compatible devices can be identified and connected via the Fixtures tab in the app. This tab displays a field of twenty-four buttons that can be assigned to Aria compatible devices that are within range, and the buttons will automatically be assigned to devices in the order in which they are discovered. If more than twenty-four units are within range, it may be necessary to use the filter feature to search for the desired fixture. Button location can be edited by selecting the configuration key, then the user can drag and drop the buttons to the desired location and hit save to keep changes. Once a device is known to the app, it can also be assigned to a particular button. **From that point forward, the assigned device will always be assigned to that button location.**

**IMPORTANT NOTE:** For version 0.65 or higher, a shared system password is required to connect to any device.

Unlike wireless DMX, Bluetooth is a connect first protocol. To connect to a device or fixture, tap the assigned button in the **Fixtures** tab. If the connection is successful, a green frame will appear around the button, indicating that the app was able to retrieve the current channel values from the fixture. The app must be connected to a fixture in order to use its channel controls or view and change settings. **Please note that not all Aria devices have channel controls.**

Additionally, each fixture can only be connected to one device with the app at any given time. Once a fixture is connected to the app installed on one device, any other devices will be blocked from connecting. As a result, when setting up a new fixture for the first time, best practice is to have only a single user with the app open within range, in order to ensure that the fixture pairs to the intended user's device.

# ARIA SETUP AND GUIDELINES

The second table section shows all Aria devices detected in range. A checkmark indicates the device is currently assigned to a button. If more than 24 devices are within range, the user may remove or add devices to the buttons list by tapping a row to check or uncheck a device. If all buttons are full, it will be necessary to uncheck a device before adding another.

**Filter:** The user can filter which Aria devices get button assignments by tapping “filter” at the top of the view. A popup will appear where the user can enter text to filter devices by username, model name, or manufacturer. **Please note that these searches are case sensitive.**

**Note:** If a device shows an asterisk (\*) it means that there is no fixture profile currently available, and therefore there will be limited support available for that device. The user will still be able to connect and adjust channels if the device supports that feature, but the user will not be able to view how many channels the device has or the channel names.

## SECURITY

Each fixture must have a password saved to be secure. When a new fixture is installed for the first time, its password will automatically be set to the app’s system password on first connection. Once the password has been entered, the user will need to exit out to the main page containing the fixture buttons, then de-select and re-select the fixture to lock in the password. From that point forward only, controlling devices that use the correct password can connect to this fixture. **This security is now required by law in most jurisdictions.**

The app will detect any Aria capable fixture within range, even if the app does not have the password to that fixture and therefore cannot access that fixture. If that fixture is selected in the app, the green frame will momentarily appear around that fixture’s button, but then disappear. This indicates that the fixture is visible but inaccessible.

# SYSTEM MENU

The fixture includes an easy to navigate system menu. The control panel (see image below) located on the front of the fixture, provides access to the main system menu and is where all necessary system adjustments are made to the fixture. During normal operation, pressing **ENTER** button once will access the fixture's main menu. Once in the main menu you can navigate through the different functions and access the submenus with the **UP** and **DOWN** buttons. Once you reach a field that requires adjusting, press the **ENTER** button to activate that field and use the **UP** and **DOWN** buttons to adjust the field. Pressing the **ENTER** button once more will confirm your setting. You may exit the main menu at any time without making any adjustments by pressing the **ENTER** button.

**Unlock Screen:** Press **UP, DOWN, UP, DOWN, ENTER**.

## Display Shortcuts:

**Power Off:** Long press the **ENTER** button for 3s, activate battery mode

**Power On:** Long press the **ENTER** button for 10s, unlock display, show 10s countdown.

Long press the **UP** button and the **DOWN** button for 3s, disable Pan Tilt.

Long press the **BACK** button and the **ENTER** button for 5s, countdown 10 sec or Reset to Default.

**NOTE:** To access the LCD Menu Control Display via the internal battery, press and hold the **MODE/ESC** button for 10 seconds. The LCD Menu Control Display will shut **OFF** automatically about 1 minute from the last button press.

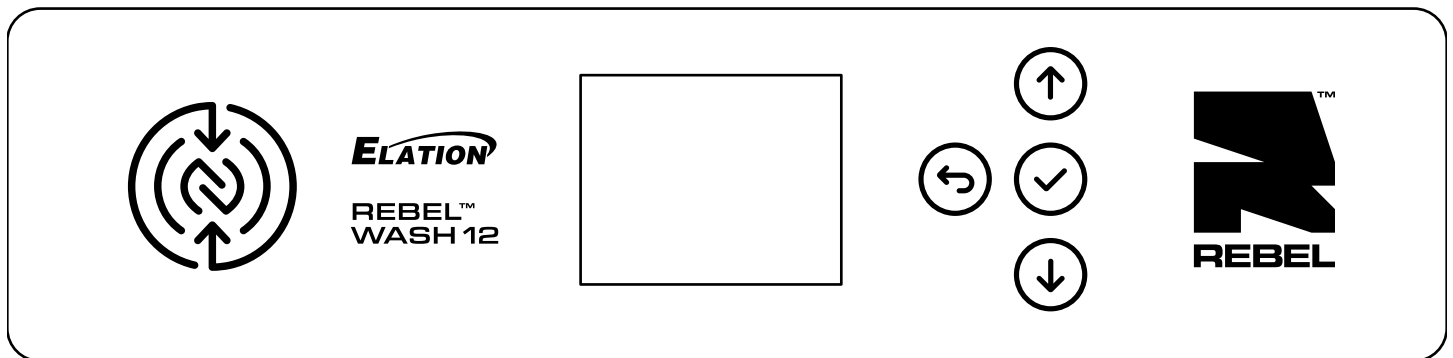

**IMPORTANT: THIS FIXTURE IS EQUIPED WITH ARIA X2. ARIA'S WIRELESS FEATURES HAE BEEN SET TO OFF BY DEFAULT. ACTIVATE ARIA X2 AND BLUETOOTH IN THE SYSTEMS MENU TO TAKE ADVANTAGE OF ITS WIRELESS FEATURE SET FOR WIRELESS CONNECTIVITY AND OVER THE AIR SOFTWARE UPDATES.**



**AN ELATION C-LOADER CAN BE USED TO UPDATE THE FIXTURE TO THE LATEST SOFTWARE. SEE PAGE 41 FOR INSTRUCTIONS. TO ORDER THIS DEVICE, PLEASE CONTACT ELATION SUPPORT FOR FURTHER DETAILS.**

**ELATION SERVICE USA - Monday - Friday 8:00am to 4:30pm PST  
323-582-3322 | support@elationlighting.com**

**ELATION SERVICE EUROPE - Monday - Friday 08:30 to 17:00 CET  
+31 45 546 85 63 | support@elationlighting.eu**

# SYSTEM MENU

MAIN MENU	OPTIONS / VALUES (Default Settings in <b>BOLD</b> )		
<b>DMX</b>	DMX Address	<b>001</b> - xxx	
	DMX Mode	Standard, <b>Extended</b> , Pixels	
	No DMX Status	<b>Hold Last</b> , Fade to Black, Sun Protection	
		Hibernation	Off, 1-99M (Default = <b>15 Min</b> )
	Protocol	Select Signal	<b>DMX</b> , Art-Net, sACN, Aria In-DMX Out, DMX In - Aria Out
		Universe	1
		DHCP	<b>Off</b> /On
		IP Address	2.x.x.x
		Subnet Mask	255.0.0.0
		Ethernet DMX Out	<b>Off</b> /On
	Aria	Enable Aria	<b>Off</b> / On
		Frequency	<b>2.4Ghz</b> / Sub Gig- US / Sub Gig- EU
		2.4Ghz Chan	<b>00-15</b>
		Sub Gig Chan	<b>00-09</b>
Enable Mesh		<b>Off</b> / On	
Enable Bluetooth	<b>Off</b> / On		
<b>Control</b>	Manual Control	Dimmer 0% - <b>100%</b> , Pan, Tilt, ...	
	Reset	All, Pan Tilt, Color, Gobo, Shutter, Others	
	Self Test	All, Dimmer, Movement, Color Mix, Gobo, Beam	
<b>Settings</b>	Fan Mode	Mute, Studio, Low, High, <b>Auto</b>	
	Movement	Pan Invert	<b>Off</b> /On
		Tilt Invert	<b>Off</b> /On
		Pan Degree	360/ <b>540</b>
		Tilt Degree	360/ <b>270</b>
		PanTilt Path	Shortest Path / <b>Continue Path</b>
		Pan Tilt Speed	Smooth/ <b>Fast</b>
	Pan Tilt Feedback	Off/ <b>On</b>	
	Dimmer Curve	Linear, Squire, Square Inverse, <b>S-Curve</b>	
	Dimmer Mode	Standard, Stage, TV, Architectural, Theatre, Stage 2	
		Dim Speed	0s - 10s
	LED Refresh Rate	900Hz - 1500Hz ( <b>1200Hz</b> ), 2500Hz, 4000Hz, 5000Hz, 6000Hz, 10KHz, 15KHz, 20KHz, 25KHz	
	LED Power Limit	50%, 60%, 70%, 80%, 90%, <b>100%</b>	
	Display	Screen Delay	10s - 5min (Default = <b>1 min</b> )
Screen Lock		<b>Off</b> , 10s - 5 min	
Auto Rotate		Off/ <b>On</b>	
Reset Defaults	Yes / No		
<b>Information</b>	Time	Current Time, Total Run Time, Last Run Time, LED Time	
	Temperature	Head, Base, LED	
	Humidity	Head, Base	
	Fan	Fan xx, ...	
	DMX Values	Pan, Tilt, ...	
	Product IDs	RDM UID	
	Error Logs	Fixture Errors	
	Software Version	Vx.x	
<b>Service</b> (Passcode <b>50</b> )	Calibration	Dimmer, Pan, Tilt, ...	
	Reset Last Run	Yes / No	
	Reset Error Logs	Yes / No	

## Display Shortcuts

<b>Power On</b>	Up, Down, Up, Down, Enter	Unlock display
	Up+Down (3s)	Disable Pan Tilt
	Back+Enter (10s)	Countdown 10 sec
		Reset Default (no/yes)

# SUN PROTECTION MODE

The fixture incorporates an automatic protection from harmful sunlight, which can damage a fixture's internal components from extended exposure. Fixtures use an internal sensor to determine their physical orientation, then reorient the fixture towards the ground to prevent sunlight from entering the lens.

This automatic feature only works when the fixture is powered. If the fixture is unpowered during setup, it is necessary to manually reorient the lenses away from the sun, and aim them towards the ground. Even a few minutes of sun exposure can cause damage inside the fixture.

The Sun Protection setting is accessed via the "No DMX Status" menu.

The automatic sun protection positioning is activated under the following conditions:

1. Power on without DMX signal: the fixture always starts in sun protection mode.
2. No DMX Status "Sun Protection": the fixture enters sun protection mode after approximately 3 minutes.
3. Remote DMX control: the sun protection position can be **temporarily** activated from the lighting console without the need to create a custom position preset. The fixture senses the correct ground orientation. This means that fixtures already facing the ground may not move their heads.

Hold "Sun Protect Position" for 3s to set the fixture to the sun protection position.

Sun protection status displays as "**Sun Protection: Active**".

The sun protection position deactivates under the following conditions:

1. Connect DMX signal.
2. Remote DMX control: Hold "Sun Protection Off" for 3s.

To avoid harsh or jarring movements, the sun protection position always uses a 5-second fade time when it is activated or deactivated.

# HIBERNATION MODE

To reduce wear on the fixture and its components, this mode disables motors and most electronics. Set the hibernation mode countdown time in the Display Menu: "Status Settings / Personality / Hibernation". Hibernation can be fully disabled.

The hibernation mode activates under the following conditions:

1. Loss of DMX: the fixture enters hibernation after the timeout expires. Default is 15 minutes.
2. Remote DMX control: Hold "Hibernate Fixture" for 3s

The hibernation mode deactivates under the following conditions:

1. Connect DMX Signal
2. Remote DMX control: Hold "Hibernate Off" for 3s

The fixture will perform a full calibration cycle, then assume the current DMX status.

Please note that the Hibernation does not change the PT position of the fixtures, allowing the user to set the desired position and then issue the Hibernate command.

To ensure the fixture is protected from harmful sunrays it is recommended to either leave the "No DMX Status" in "Sun Protection" (so the fixture is already in the correct position after 3 minutes of DMX loss) or set the fixture to a safe Tilt position manually first before hibernation.

**Burn and heat damage to the fixture's interior components due to external light sources (sun or other fixtures shining into the lens) is never covered under the manufacturers warranty.**

# FAN MODES AND LOW NOISE OPERATION

This fixture is a high-performance fixture suited for many applications. For noise critical environments like Theater, Opera or Orchestra Halls, it offers various operation modes to remove any distraction for the audience and performers. Modes can be changed remotely via the DMX control channel, allowing the fixture to offer high output or quiet operation at a moment's notice. All modes smoothly transition over a brief period, preventing unwanted attraction to the fixture.

## Fan Modes

**Auto** – The default AUTO mode ensures optimal performance of the fixture. Fans only run at the speeds needed to keep the LED engine within a safe temperature range. They will turn off if possible, for example when the fixture is dimmed to a low intensity. Fans sense the ambient and fixture temperature, and will at all times try to keep noise levels at a minimum. The fixture output will only reduce when the LED engine cannot be cooled down to its safe operating range due to high ambient temperature. **Auto is the recommend mode for daily operation of the Rebel Wash 12.**

**Low** – In this mode the fixture reduces fan speeds throughout for a lower noise profile of the fixture. This mode should be sufficient for most uses where lower noise is required. The fixture output is reduced to about 80%.

**High** – This mode is only required in very high ambient temperatures when automatic fan speed adjustments are not desired. High Fan Speed will cool the fixture most efficiently. This mode will increase wear on the fans and should only be utilized in exceptional circumstances. Fans will always run, even if the fixture is dimmed. Fixture output is kept at 100% unless the LED engine temperature is too high, at which point the fixture will reduce power carefully to ensure safe operation.

## Low Noise Modes

For very critical situations, the fixture offers two additional low noise modes for silent operation. The fixture output will be reduced, but as the fixture has such an extremely high luminous flux, it still offers outstanding performance.

**Studio** – This mode reduces the fixture output to approximately 50%.

**Mute** – Running the fixture in MUTE mode reduces the fixture to about 25% output.

# DIMMER MODE

DIMMER

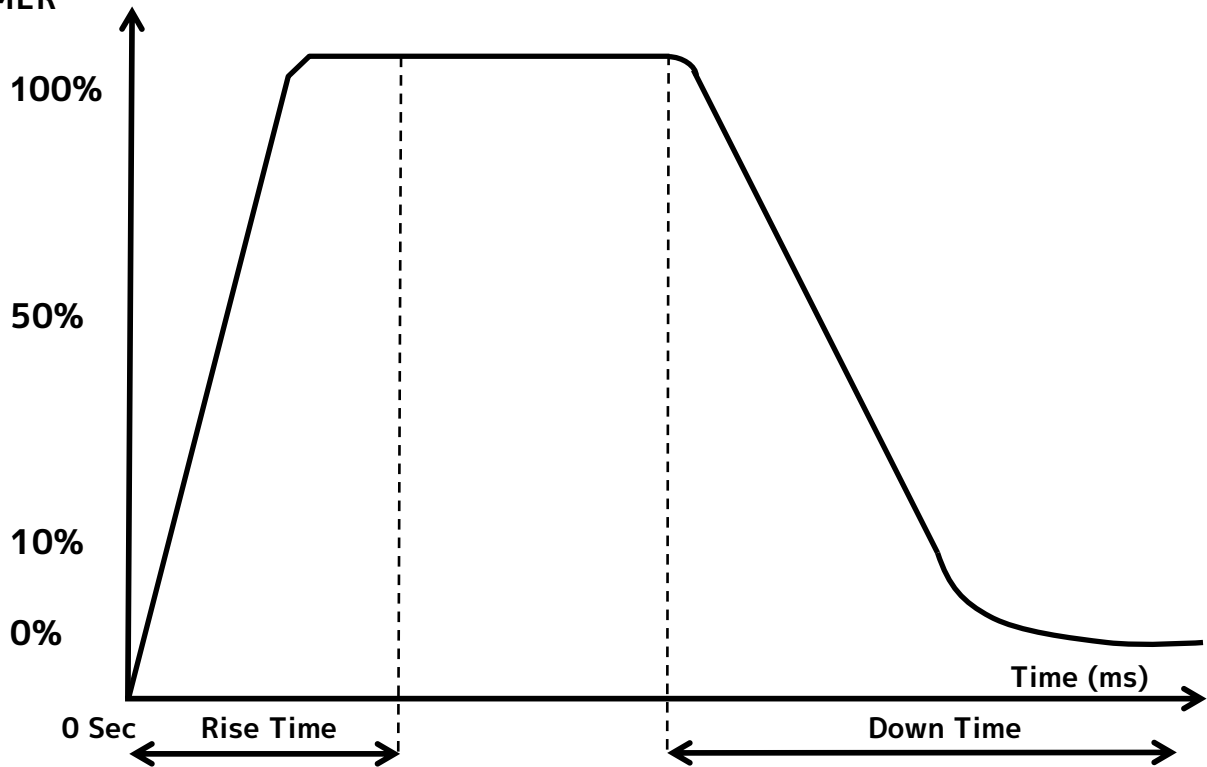

Dimming Curve Ramp Effect	0 sec Fade Time		1 sec Fade Time	
	Rise Time (ms)	Down Time (ms)	Rise Time (ms)	Down Time (ms)
Standard (default)	0	0	0	0
Stage	780	1100	1540	1660
TV	1180	1520	1860	1940
Architectural	1380	1730	2040	2120
Theatre	1580	1940	2230	2280
Stage 2	0	1100	0	1660

# DIMMER CURVE

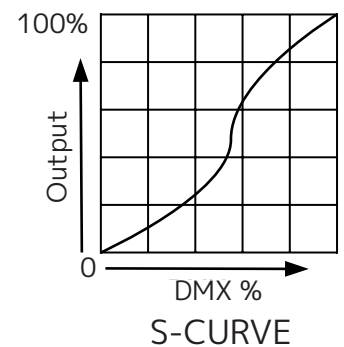
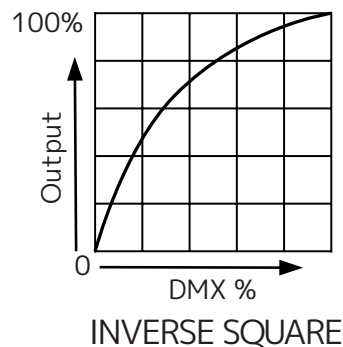
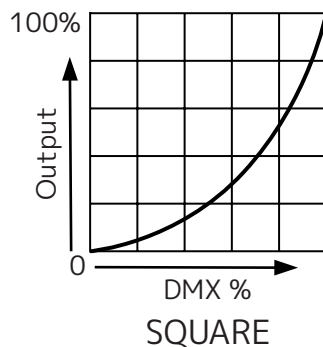
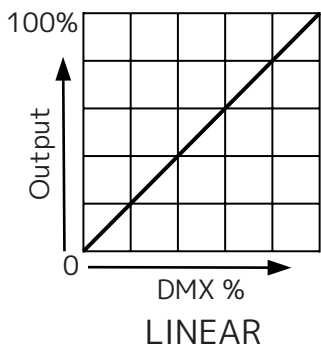

# DMX TRAITS

MODE/CHANNEL			VALUE	FUNCTION	SNAP	DEFAULT	
STANDARD	EXTENDED	PIXELS					
1	1	1	0-255	<b>Pan</b>			
				Left → Right			
2	2	2	0-255	<b>Pan Fine</b>			
				Fine Position			
3	3	3	0-255	<b>Tilt</b>			
				Forward → Backward			
4	4	4	0-255	<b>Tilt Fine</b>			
				Fine Position			
5	5	5		<b>Pan Rotation</b>			
				0-2			Disabled
				3-126			Clockwise Fast → Slow
				127-129			Stop
				130-253			Counter-clockwise Slow → Fast
254-255	Stop						
6	6	6		<b>Tilt Rotation</b>			
				0-2			Disabled
				3-126			Clockwise Fast → Slow
				127-129			Stop
				130-253			Counter-clockwise Slow → Fast
254-255	Stop						
7	7		0-255	<b>Red</b>			
				0 → 100%			
	8		0-255	<b>Red Fine</b>			
				Fine Saturation			
8	9		0-255	<b>Green</b>			
				0 → 100%			
	10		0-255	<b>Green Fine</b>			
				Fine Saturation			
9	11		0-255	<b>Blue</b>			
				0 → 100%			
	12		0-255	<b>Blue Fine</b>			
				Fine Saturation			
10	13		0-255	<b>Lime</b>			
				0 → 100%			
	14		0-255	<b>Lime Fine</b>			
				Fine Saturation			
11	15	7		<b>Variable CCT</b>			
				0-23			Open (6000K)
				24-255			2400K → 8500K (see table)
	16	8	0-255	<b>Variable CCT Fine</b>			
				Fine Adjustment			
12	17	9		<b>Color</b>			
				0			Open
				1-179			Virtual Swatch Book (See Sheet)
							<b>Scroll</b>
				180-201			Clockwise Fast → Slow
				202-207			Stop
				208-229			Counter-clockwise Slow → Fast
				230-234			Open
							<b>Random Slots</b>
				235-239			Fast
240-244	Medium						
245-249	Slow						
250-255	Open						

# DMX TRAITS

MODE/CHANNEL			VALUE	FUNCTION	SNAP	DEFAULT	
STANDARD	EXTENDED	PIXELS					
13	18	10	0-255	<b>Zoom</b>			
				Narrow → Wide			
14	19	11	0-255	<b>Zoom Fine</b>			
				Fine Adjustment			
15	20	12		<b>Strobe</b>			
				0-31			Closed
				32-63			Open
				64-95			Strobe effect slow to fast
				96-127			Open
				128-159			Pulse Effect
				160-191			Open
				192-223			Random Slow → Fast
224-255	Open						
16	21	13	0-255	<b>Dimmer</b>			
				0 → 100%			
17	22	14	0-255	<b>Dimmer Fine</b>			
				Fine Adjustment			
	23	15		<b>Dimmer Modes</b>	X		
				0-20			Standard
				21-40			Stage
				41-60			TV
				61-80			Architectural
				81-100			Theatre
				101-120			Stage 2
							<b>Dimmer Time</b>
				121			0s
				122			0.1s
				123			0.2s
				124			0.3s
				125			0.4s
				126			0.5s
				127			0.6s
				128			0.7s
				129			0.8s
				130			0.9s
				131			1.0s
				132			1.5s
				133			2.0s
				134			3.0s
				135			4.0s
				136			5.0s
				137			6.0s
				138			7.0s
				139			8.0s
140	9.0s						
141	10s						
141-255	Idle						
	24	16		<b>Pan / Tilt Speed</b>	X		
				0-225			Max → Min Speed
				226-235			Blackout by movement
				236-245			Blackout by wheel changes
				246-255			No function

# DMX TRAITS

MODE/CHANNEL			VALUE	FUNCTION	SNAP	DEFAULT
STANDARD	EXTENDED	PIXELS				
18	25	17		<b>Control</b>		
			0-10	Idle		
				<b>Movement Options</b>		
			11-12	PanTilt Shortest Path		
			13-14	PanTilt Continue Path (default)		
			15-16	Pan Range 540 (default)		
			17-18	Pan Range 360		
			19-20	Tilt Range 270 (default)		
			21-22	Tilt Range 360		
			23-29	Idle		
				<b>Fan Mode</b>		
			30-39	Mute		
			40-49	Studio		
			50-59	Low		
			60-69	High		
			70-79	Auto		
				<b>Reset</b>		
			80-84	All		
			85-87	Pan / Tilt		
			88-90	Zoom		
			97-99	Idle		
				<b>Refresh Rate (Hz)</b>		
			100	900		
			101	910		
			102	920		
			103	930		
			104	940		
			105	950		
			106	960		
			107	970		
			108	980		
			109	990		
110	1000					
111	1010					
112	1020					
113	1030					
114	1040					
115	1050					
116	1060					
117	1070					
118	1080					
119	1090					
120	1100					
121	1110					
122	1120					
123	1130					
124	1140					
125	1150					

MODE/CHANNEL			VALUE	FUNCTION	SNAP	DEFAULT
STANDARD	EXTENDED	PIXELS				
18	25	17	126	1160		
			127	1170		
			128	1180		
			129	1190		
			130	<b>1200</b>		
			131	1210		
			132	1220		
			133	1230		
			134	1240		
			135	1250		
			137	1270		
			138	1280		
			139	1290		
			140	1300		
			141	1310		
			142	1320		
			143	1330		
			144	1340		
			145	1350		
			146	1360		
			147	1370		
			148	1380		
			149	1390		
			150	1400		
			151	1410		
			152	1420		
			153	1430		
			154	1440		
			155	1450		
			156	1460		
			157	1470		
			158	1480		
			159	1490		
			160	1500		
			161	2500		
			162	4000		
			163	5000		
			164	6000		
			165	10000		
			166	15000		
			167	20000		
			168	25000		
			100-168	See table		
			169-174	Idle		
			185-200	Idle		
	<b>Dimmer Curves</b>					
201-210	Linear					
211-220	Square					
221-230	Inverse Square					
231-240	S-Curve (Default)					
241-255	Idle					

MODE/CHANNEL			VALUE	FUNCTION	SNAP	DEFAULT
STANDARD	EXTENDED	PIXELS				
19	26	18		<b>FX Selection</b>	X	0
			0	Idle		
			1-255	FX 1 → 255		
20	27	19		<b>FX Speed</b>		0
			0-126	Slow → Fast		
			127-128	Stop		
			129-255	Rev Fast → Slow		
21	28	20		<b>FX Offset</b>	X	0
			0	Idle		
			1	Fixture Offset 10 Degrees		
			2	Fixture Offset 20 Degrees		
			3-34	Fixture Offset...		
			35	Fixture Offset 350 Degrees		
			36	Synchronized		
			37-49	Random Fixture Offset		
			50-59	Random Pixel Order		
			60-69	Random Steps		
			70-79	Idle		
				<b>Effect Fade</b>		
			80-89	Sinewave- Cross		
			90-99	Sinewave- Full		
			100-109	Sawtooth- Cross		
			110-119	Sawtooth- Full		
			120-129	Ramp Up		
130-139	Ramp Down					
140-149	Steps					
	150-255	Idle				

# DMX TRAITS: RGLB PIXELS

MODE/CHANNEL			VALUE	FUNCTION	SNAP	DEFAULT
STANDARD	EXTENDED	PIXELS				
		21	0-255	<b>Red 1</b> 0 → 100%		
		22	0-255	<b>Green 1</b> 0 → 100%		
		23	0-255	<b>Blue 1</b> 0 → 100%		
		24	0-255	<b>Lime 1</b> 0 → 100%		
		25	0-255	<b>Red 2</b> 0 → 100%		
		26	0-255	<b>Green 2</b> 0 → 100%		
		27	0-255	<b>Blue 2</b> 0 → 100%		
		28	0-255	<b>Lime 2</b> 0 → 100%		
		29	0-255	<b>Red 3</b> 0 → 100%		
		30	0-255	<b>Green 3</b> 0 → 100%		
		31	0-255	<b>Blue 3</b> 0 → 100%		
		32	0-255	<b>Lime 3</b> 0 → 100%		
		33	0-255	<b>Red 4</b> 0 → 100%		
		34	0-255	<b>Green 4</b> 0 → 100%		
		35	0-255	<b>Blue 4</b> 0 → 100%		
		36	0-255	<b>Lime 4</b> 0 → 100%		
		37	0-255	<b>Red 5</b> 0 → 100%		
		38	0-255	<b>Green 5</b> 0 → 100%		
		39	0-255	<b>Blue 5</b> 0 → 100%		
		40	0-255	<b>Lime 5</b> 0 → 100%		
		41	0-255	<b>Red 6</b> 0 → 100%		
		42	0-255	<b>Green 6</b> 0 → 100%		
		43	0-255	<b>Blue 6</b> 0 → 100%		
		44	0-255	<b>Lime 6</b> 0 → 100%		
		45	0-255	<b>Red 7</b> 0 → 100%		
		46	0-255	<b>Green 7</b> 0 → 100%		
		47	0-255	<b>Blue 7</b> 0 → 100%		
		48	0-255	<b>Lime 7</b> 0 → 100%		

# DMX TRAITS: RGLB PIXELS

MODE/CHANNEL			VALUE	FUNCTION	SNAP	DEFAULT
STANDARD	EXTENDED	PIXELS				
		49	0-255	<b>Red 8</b> 0 → 100%		
		50	0-255	<b>Green 8</b> 0 → 100%		
		51	0-255	<b>Blue 8</b> 0 → 100%		
		52	0-255	<b>Lime 8</b> 0 → 100%		
		53	0-255	<b>Red 9</b> 0 → 100%		
		54	0-255	<b>Green 9</b> 0 → 100%		
		55	0-255	<b>Blue 9</b> 0 → 100%		
		56	0-255	<b>Lime 9</b> 0 → 100%		
		57	0-255	<b>Red 10</b> 0 → 100%		
		58	0-255	<b>Green 10</b> 0 → 100%		
		59	0-255	<b>Blue 10</b> 0 → 100%		
		60	0-255	<b>Lime 10</b> 0 → 100%		
		61	0-255	<b>Red 11</b> 0 → 100%		
		62	0-255	<b>Green 11</b> 0 → 100%		
		63	0-255	<b>Blue 11</b> 0 → 100%		
		64	0-255	<b>Lime 11</b> 0 → 100%		
		65	0-255	<b>Red 12</b> 0 → 100%		
		66	0-255	<b>Green 12</b> 0 → 100%		
		67	0-255	<b>Blue 12</b> 0 → 100%		
		68	0-255	<b>Lime 12</b> 0 → 100%		

# COLOR TEMPERATURE

DMX	CCT	DMX	CCT	DMX	CCT	DMX	CCT	DMX	CCT
24	2400K	71	3622K	118	4844K	165	6066K	212	7288K
25	2426K	72	3648K	119	4870K	166	6092K	213	7314K
26	2452K	73	3674K	120	4896K	167	6118K	214	7340K
27	2478K	74	3700K	121	4922K	168	6144K	215	7366K
28	2504K	75	3726K	122	4948K	169	6170K	216	7392K
29	2530K	76	3752K	123	4974K	170	6196K	217	7418K
30	2556K	77	3778K	124	5000k	171	6222K	218	7444K
31	2582K	78	3804K	125	5026K	172	6248K	219	7470K
32	2608K	79	3830K	126	5052K	173	6274K	220	7496K
33	2634K	80	3856K	127	5078K	174	6300K	221	7522K
34	2660K	81	3882K	128	5104K	175	6326K	222	7548K
35	2686K	82	3908K	129	5130K	176	6352K	223	7574K
36	2712K	83	3934K	130	5156K	177	6378K	224	7600K
37	2738K	84	3960K	131	5182K	178	6404K	225	7626K
38	2764K	85	3986K	132	5208K	179	6430K	226	7652K
39	2790K	86	4012K	133	5234K	180	6456K	227	7678K
40	2816K	87	4038K	134	5260K	181	6482K	228	7704K
41	2842K	88	4064K	135	5286K	182	6508K	229	7730K
42	2868K	89	4090K	136	5312K	183	6534K	230	7756K
43	2894K	90	4116K	137	5338K	184	6560K	231	7782K
44	2920K	91	4142K	138	5364K	185	6586K	232	7808K
45	2946K	92	4168K	139	5390K	186	6612K	233	7834K
46	2972K	93	4194K	140	5416K	187	6638K	234	7860K
47	2998K	94	4220K	141	5442K	188	6664K	235	7886K
48	3024K	95	4246K	142	5468K	189	6690K	236	7912K
49	3050K	96	4272K	143	5494K	190	6716K	237	7938K
50	3076K	97	4298K	144	5520K	191	6742K	238	7964K
51	3102K	98	4324K	145	5546K	192	6768K	239	7990K
52	3128K	99	4350K	146	5572K	193	6794K	240	8016K
53	3154K	100	4376K	147	5598K	194	6820K	241	8042K
54	3180K	101	4402K	148	5624K	195	6846K	242	8068K
55	3206K	102	4428K	149	5650K	196	6872K	243	8094K
56	3232K	103	4454K	150	5676K	197	6898K	244	8120K
57	3258K	104	4480K	151	5702K	198	6924K	245	8146K
58	3284K	105	4506K	152	5728K	199	6950K	246	8172K
59	3310K	106	4532K	153	5754K	200	6976K	247	8198K
60	3336K	107	4558K	154	5780K	201	7002K	248	8224K
61	3362K	108	4584K	155	5806K	202	7028K	249	8250K
62	3388K	109	4610K	156	5832K	203	7054K	250	8276K
63	3414K	110	4636K	157	5858K	204	7080K	251	8302K
64	3440K	111	4662K	158	5884K	205	7106K	252	8328K
65	3466K	112	4688K	159	5910K	206	7132K	253	8354K
66	3492K	113	4714K	160	5936K	207	7158K	254	8380K
67	3518K	114	4740K	161	5962K	208	7184K	255	8500K
68	3544K	115	4766K	162	5988K	209	7210K		
69	3570K	116	4792K	163	6014K	210	7236K		
70	3596K	117	4818K	164	6040K	211	7262K		

# VIRTUAL COLORS (COLOR SWATCH)

VALUE	FILTER #	COLOR	VALUE	FILTER #	COLOR
1	7	Pale Yellow	31	126	Mauve
2	103	Straw	32	49	Medium Purple
3	151	Gold Tint	33	58	Lavender
4	100	Spring Yellow	34	199	Palace Blue
5	10	Medium Yellow	35	119	Dark Blue
6	101	Yellow	36	132	Medium Blue
7	104	Deep Amber	37	120	Deep Blue
8	15	Deep Straw	38	165	Daylight Blue
9	179	Loving Amber	39	161	Slate Blue
10	21	Gold Amber	40	118	Light Blue
11	105	Orange	41	68	Sky Blue
12	158	Deep Orange	42	143	Pale Navy Blue
13	22	Dark Amber	43	131	Marine Blue
14	778	Millennium Gold	44	115	Peacock Blue
15	135	Deep Golden Amber	45	172	Lagoon Blue
16	24	Scarlet	46	116	Medium Blue Green
17	106	Primary Red	47	90	Dark Yellow Green
18	26	Bright Red	48	139	Primary Green
19	27	Medium Red	49	122	Fern Green
20	19	Fire	50	89	Moss Green
21	157	Pink	51	124	Dark Green
22	36	Medium Pink	52	88	Lime Green
23	111	Dark Pink	53	138	Pale Green
24	128	Bright Pink	54	203	Quarter CT Blue
25	148	Bright Rose	55	202	Half CT Blue
26	332	Special Rose Pink	56	201	FULL CT Blue
27	793	Vanity Fair	57	200	Double CT Blue
28	113	Magenta	58	206	Quarter CT Orange
29	46	Dark Magenta	59	205	Half CT Orange
30	48	Rose Purple	60	204	FULL CT Orange

# REMOTE DEVICE MANAGEMENT (RDM)

**NOTE: In order for RDM to work properly, RDM enabled equipment must be used throughout the entire system, including DMX data splitters and wireless systems.**

Remote Device Management (RDM) is a protocol that sits on top of the DMX512 data standard for lighting, allowing the DMX systems of the fixtures to be modified and monitored remotely. This protocol is ideal for instances in which a unit is installed in a location that is not easily accessible.

With RDM, the DMX512 system becomes bi-directional, allowing a compatible RDM enabled controller to send out a signal to devices on the wire, as well as allowing the fixture to respond (known as a GET command). The controller can then use its SET command to modify settings that would typically have to be changed or viewed directly via the unit's display screen, including the DMX Address, DMX Channel Mode, and Temperature Sensors.

## FIXTURE RDM INFORMATION:

RDM Code	Device ID	Device Model ID	Personality ID
0x22A6	0-0XFFFF	0x0065	Standard (21) Extended (28) Pixels (68)

**Please be aware that not all RDM devices support all RDM features,** and therefore it is important to check beforehand to ensure that the equipment that you are considering includes all of the features that you require.

The following parameters are accessible in RDM on this device:

[0x0011] Proxied Device Count	[0x0600] Pan Invert
[0x0200] Sensor Definition	[0x0601] Tilt Invert
[0x0201] Sensor Value	[0x0602] Pan Tilt Swap
[0x0080] Device Model Description	[0x0500] Display Invert
[0x0081] Manufacturer Label	[0x0501] Display Level
[0x0082] Device Label	[0x0603] Realtime Clock
[0x00E0] DMX Personality	[0x1010] Power State
[0x00E1] DMX Personality Description	[0x1031] Preset Playback
[0x0400] Device Hours	[0x0122] Default Slot Value
[0x0015] Comms Status	[0x00C2] Boot Software Version Label
[0x0031] Status ID Description	[0x00C1] Boot Software Version ID
[0x0032] Clear Status ID	[0x0070] Product Detail ID List
[0x0405] Device Power Cycles	[0x0030] Status Messages

# MAINTENANCE GUIDELINES



**DISCONNECT POWER BEFORE PERFORMING ANY MAINTENANCE!**

## CLEANING

Frequent cleaning is recommended to ensure proper function, optimized light output, and an extended life. The frequency of cleaning depends on the environment in which the fixture operates: damp, smoky or particularly dirty environments can cause greater accumulation of dirt on the fixture's optics. Periodically clean the external lens surface with a soft cloth to avoid dirt/debris accumulation. **NEVER** use alcohol, solvents, or ammonia-based cleaners.

## MAINTENANCE

Regular inspections are recommended to ensure proper function and extended life. There are no user serviceable parts inside this fixture. Please refer all other service issues to an authorized Elation service technician. Should you need any spare parts, please order genuine parts from your local Elation dealer.

Please refer to the following points during routine inspections:

- A detailed electric check by an approved electrical engineer every three months, to make sure the circuit contacts are in good condition and prevent overheating.
- Be sure all screws and fasteners are securely tightened at all times. Loose screws may fall out during normal operation, resulting in damage or injury as larger parts could fall.
- Check for any deformations on the housing, color lenses, rigging hardware, and rigging points (ceiling, suspension, trussing). Deformations in the housing could allow for dust to enter into the fixture. Damaged rigging points or unsecured rigging could cause the fixture to fall and seriously injure a person(s).
- Electric power supply cables must not show any damage, material fatigue or sediments. **NEVER** remove the ground prong from the power cable.

## FIXTURE DISASSEMBLY

The following points should be observed after performing any maintenance procedure that requires disassembly of the unit:

- After the unit has been reassembled, open the valve and allow the unit to run for approximately 2 hours in order to dry out any moisture that has been trapped inside the fixture. The process should continue until indicated humidity drops below 15% for the head and 30% for the base.
- Once this has been achieved, the light can be switched off, but the unit should remain connected to power so that the cooling fan can cool down the unit. Please note that allowing cool down time should **ALWAYS** be done after lamp operation.
- Some units may require partial disassembly in order to gain access to the valve. Please contact Elation service for information regarding the location and access procedure for the valve on your specific unit model.

# ERROR CODES

Error Codes subject to change without notice	
ERROR CODES	DESCRIPTION
<b>Pan</b>	Movement is not located in the default position after the reset. These messages will appear after a fixture reset if the magnetic-indexing circuit malfunctions (sensor failed, or magnet is missing) or there is a motor failure (defective motor or a defective motor IC drive on the main PCB). This error may also be displayed if the head/yoke was blocked during a reset function.
<b>Tilt</b>	
<b>Zoom</b>	Movement is not located in the default position after the reset. These messages will appear after a fixture reset if the magnetic-indexing circuit malfunctions (sensor failed, or magnet is missing) or there is a motor failure (defective motor or a defective motor IC drive on the main PCB).
<b>HeadFan1</b>	These messages will appear if there is a temperature and/or fan malfunction.
<b>HeadFan2</b>	
<b>LED Fan1</b>	
<b>LED Fan2</b>	
<b>LED Fan3</b>	
<b>LED Fan4</b>	
<b>BaseFan</b>	
<b>HeadTemp</b>	
<b>BaseTemp</b>	

# SOFTWARE UPDATES



**ONLY QUALIFIED TECHNICIANS SHOULD PERFORM THIS FUNCTION!  
NOTE ALL MENU SETTINGS BEFORE UPDATING SOFTWARE!  
FIXTURE SOFTWARE CAN NOT BE DOWNGRADED!  
DOWNLOAD FIXTURE SOFTWARE TO PC ONLY! (NO MAC SUPPORT)  
PLEASE CONTACT ELATION SERVICE FOR FURTHER INFORMATION.**

## **C-LOADER II**

An Elation C-Loader II can be used to update the fixture to the latest software. Please visit the C-Loader II product page at the Elation web site and download the product manual for step by step instructions.

<https://www.elationlighting.com/c-loader-software-uploader>

To order the C-Loader II uploader and the updated software for your fixture, please contact Elation support for details.

**ELATION SERVICE USA - Monday - Friday 8:00am to 4:30pm PST**  
**323-582-3322 | support@elationlighting.com**

**ELATION SERVICE EUROPE - Monday - Friday 08:30 to 17:00 CET**  
**+31 45 546 85 63 | support@elationlighting.eu**

# SPECIFICATIONS

## SOURCE

(12) 60W RGBL LED  
30,000 Hour Average LED Life\*

\*Test lab conditions. May vary depending on several factors including but not limited to: Environmental Conditions, Power/Voltage, Usage Patterns (On-Off Cycling), Control, and Dimming.

## PHOTOMETRIC DATA

14000 Total Lumen Fixture Output  
CRI - 83.4  
TLCI - 67  
Zoom Range 5° - 40°  
Beam Angle: 5° - 40°  
Field Angle: 8.5° - 56.5°

## EFFECTS

Motorized Zoom  
Pixel Control  
Variable 16-bit Dimming Curves  
High Speed Electronic Shutter and Strobe  
DMX Controllable LED Refresh Rate  
Pan Angle: 360/540°  
Tilt Angle: 360/270°  
Continuous 360° Pan and Tilt Rotation

## COLOR

RGBL Color Array  
Variable CCT 2400K - 8500K  
Virtual Gel Swatch Book

## CONTROL / CONNECTIONS

3 DMX Channel Modes (21/28/68)  
DMX, RDM, Art-NET, sACN Protocol Support  
(4) Button Touch Control Panel  
Full Color 180° Reversible LCD Menu Display  
Hibernation Mode (Power Save)  
Aria x2 Wireless Device Management  
NFC Configuration  
IP65 Locking 5pin XLR Connector In/Out  
IP65 Locking RJ45 Ethernet Connector In/Out  
IP65 Locking Power Connector In

## SIZE / WEIGHT

Length: 14.2 in (360 mm)  
Width: 10.2 in (259 mm)  
Height: 17.5 in (445 mm)  
Weight: 36.4 lbs. (16.5 kg)

## ELECTRICAL

AC 100-240V 50/60Hz  
Max Power Consumption 730W  
Power Thru Capacity: 4A (0 units @115V, 1 units @240V)  
-4° to 113°F (-20°C to 45°C)  
BTU/hr (+/- 10%) 2489.3

## INCLUDED ITEMS

Omega Brackets (x2)  
Safety Cable  
IP65 Rated Locking Power Cable

## APPROVALS / RATINGS

CE | cETLus | FCC | UKCA | IP65



# DIMENSIONS

\*Drawings not to scale. Specifications and improvements in the design of this unit and this manual are subject to change without notice.

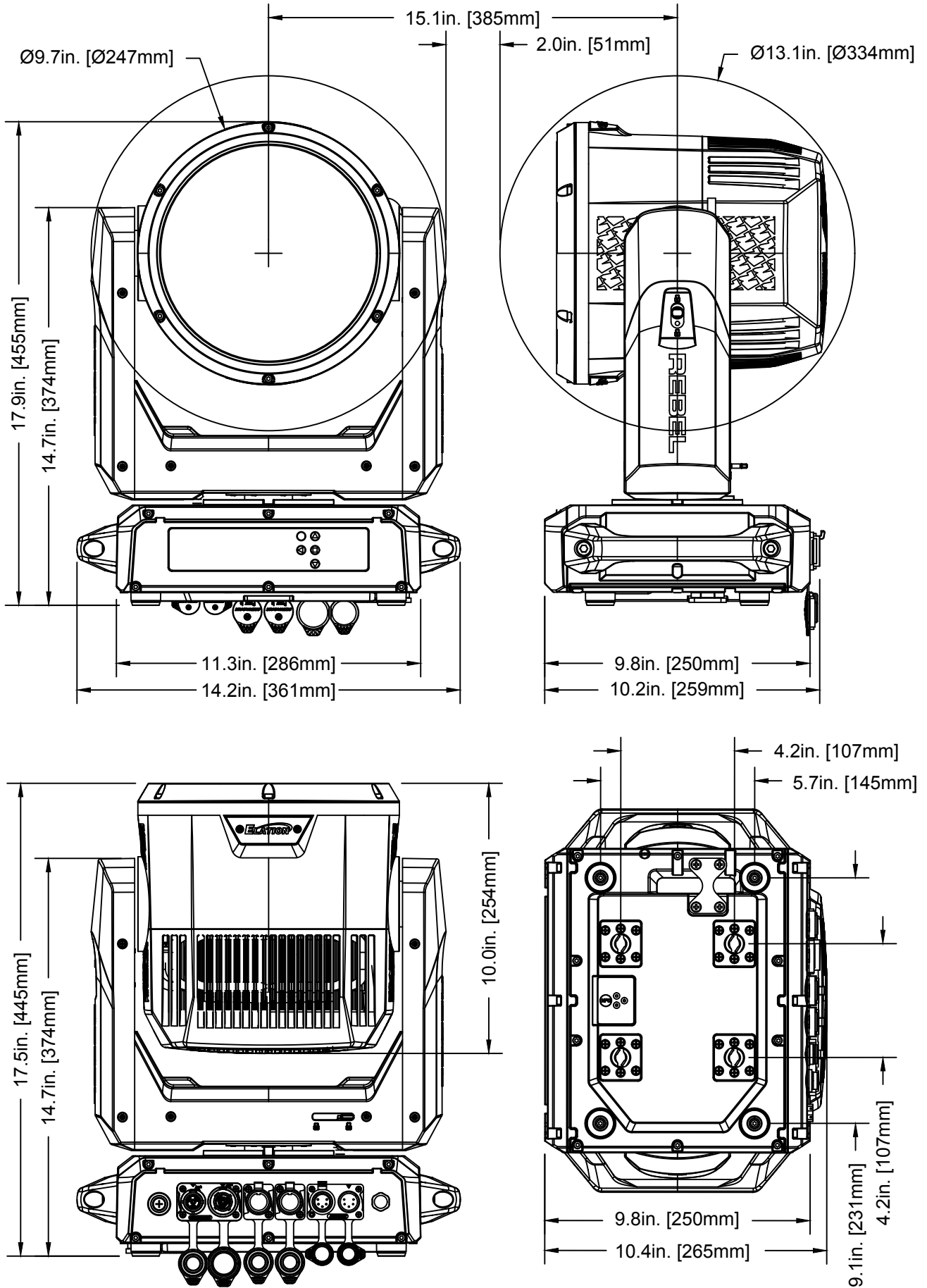

# OPTIONAL ACCESSORIES

ORDER CODE	ITEM
TRIGGER CLAMP	Heavy Duty Wrap Around Hook Style Clamp
SIP126	5 ft. (1.5m) IP65 Twist Lock Power Link Cable
TOU027	5 ft. (1.5m) 5pin PRO DMX Cable
	Additional Cable Lengths Available

## FCC STATEMENT

This device complies with Part 15 of the FCC Rules. Operation is subject to the following two conditions: (1) this device may not cause harmful interference, and (2) this device must accept any interference received, including interference that may cause undesired operation.

### FCC RADIO FREQUENCY INTERFERENCE WARNINGS & INSTRUCTIONS

This product has been tested and found to comply with the limits as per Part 15 of the FCC Rules. These limits are designed to provide reasonable protection against harmful interference in a residential installation. This device uses and can radiate radio frequency energy and, if not installed and used in accordance with the included instructions, may cause harmful interference to radio communications. However, there is no guarantee that interference will not occur in a particular installation. If this device does cause harmful interference to radio or television reception, which can be determined by turning the device off and on, the user is encouraged to try to correct the interference by one or more of the following methods:

- Reorient or relocate the device.
- Increase the separation between the device and the receiver.
- Connect the device to an electrical outlet on a circuit different from which the radio receiver is connected.
- Consult the dealer or an experienced radio/TV technician for help.

### Energy Saving Matters (EuP 2009/125/EC)

Saving electric energy is a key to help protecting the environment. Please turn off all electrical products when they are not in use. To avoid power consumption in idle mode, disconnect all electrical equipment from power when not in use. Thank you!



