



FRESNEL 8 IP



500W Full Spectrum RGBMA LED 8" Fresnel with Motorized Zoom

PRELIMINARY DATA SHEET



KEY FEATURES

500W RGBMA LED Engine

15,500 Total Fixture Lumen Output (Sphere)

Wide 8° to 60° Motorized Zoom Range

Stand-Alone control with 2 Encoders and LED Display

NFC & Aria x2 Wireless Device Management

IP65 Rated

Gel Frame & 8-leaf Barndoor Included

The **KL Fresnel 8 IP** delivers superior light quality in a compact, weather-ready 8-inch design—bringing natural Fresnel character, full-spectrum color, and modern workflow efficiency to any environment.

Its 500W RGBMA engine produces over 16,000 lumens of balanced, full-spectrum output to ensure natural skin tones and accurate color. Variable CCT and magenta/green shift control make it ideal for film and television.

An internal motorized 8°– 60° zoom uses a source-moving mechanism to preserve classic Fresnel behavior with a smooth falloff designers expect in a compact, easy-to-rig form.

Smart setup tools, including NFC configuration, a rear-facing LCD interface with dual encoders, and Aria X2 wireless DMX, streamline operation from prep to programming.

With its lightweight IP65 housing and five selectable fan modes, the **KL Fresnel 8 IP** supports everything from outdoor stages to camera-critical studio work while reducing maintenance and downtime—all while maintaining the timeless look and feel of a true Fresnel.





FRESNEL 8 IP



500W Full Spectrum RGBMA LED 8" Fresnel with Motorized Zoom

SPECIFICATIONS

SOURCE

500W 6000K RGBMA LED Engine
50,000 Hour Average LED Life*

*May vary depending on several factors including but not limited to: Environmental Conditions, Power/Voltage, Usage Patterns (On-Off Cycling), Control and Dimming.

PHOTOMETRIC DATA

Total Lumen Output:
16,028 (Integrating Sphere)
TBA (Goniometer)
CRI 94
TLCI 95
Zoom Range 8° - 60°
Beam Angle 7.5° - 43°
Field Angle 12° - 60°

EFFECTS

Motorized Zoom
Variable Strobe Rate: 1- 20Hz
Dim-to-Warm/ Red Shift Emulation
Variable 16-bit Dimming Modes and Curves
DMX Controllable LED Refresh Rate (900Hz- 25kHz)

COLOR

RGBMA Color Array
CMY Emulation
x/y Control
16bit Fully Variable CCT 2400K - 8500K
Green/Magenta Shift
Virtual Gel Swatch Book

CONTROL / CONNECTIONS

8 DMX Channel Modes (1, 5, 7, 11, 12, 20, 10, 16, 14)
Manual and DMX Controlled Dimmer, Color & Zoom
4 DMX Controllable Fan Modes for Silent Operation
Dual Rotary Encoders
Full Color 180° Reversible LCD Menu Display
RDM (Remote Device Management)
Aria x2 Wireless Device Management
NFC Configuration
IP65 5pin DMX and IP65 Locking Power Cable In/Out

SIZE / WEIGHT

Length: 17.7" (448 mm)
Length (Yoke 0°): 21.3" (540 mm)
Width: 12.2" (309 mm)
Height (Fixture Body): 13.6" (345 mm)
Height (Yoke 90°): 21.2" (538 mm)
Weight: 30.2 lbs (13.7 kg)

ELECTRICAL / THERMAL

AC 100-240V - 50/60Hz
551W Max Power Consumption
Power Thru Capacity: 8A (1 unit @115V, 3 units @240V)
5°F to 113°F (-15°C to 45°C)
BTU/hr (+/- 10%) 1878.9

INCLUDED ITEMS

Gel Frame
Safety Cable
Barndoor
IP65 Locking Power Cable

OPTIONAL ITEMS

Omega Bracket

APPROVALS / RATINGS

CE | cETLus | IP65 | FCC | UKCA



IP65





FRESNEL 8 IP



500W Full Spectrum RGBMA LED 8" Fresnel with Motorized Zoom

UNIT DIMENSIONS

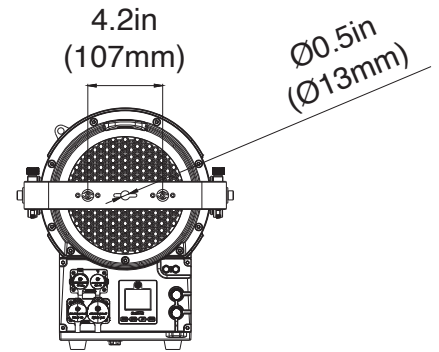
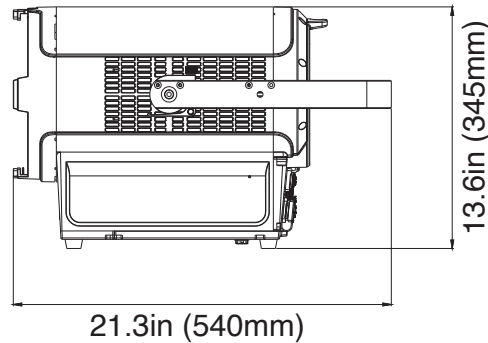
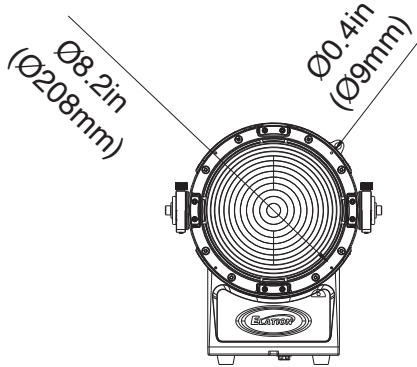
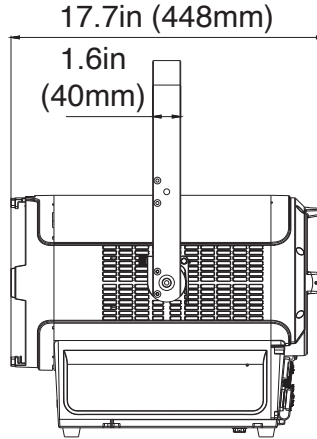
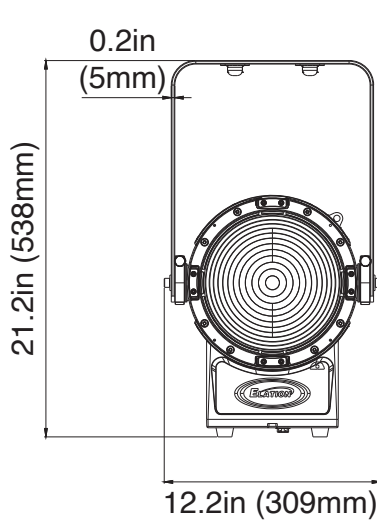

ORDERING INFORMATION

US SKU	EU SKU	DESCRIPTION
KLF925	PENDING	Elation KL Fresnel 8 IP

