



SMARTYMAX™

user manual

©2023 ELATION PROFESSIONAL all rights reserved. Information, specifications, diagrams, images, and instructions herein are subject to change without notice. ELATION PROFESSIONAL logo and identifying product names and numbers herein are trademarks of ELATION PROFESSIONAL. Copyright protection claimed includes all forms and matters of copyrightable materials and information now allowed by statutory or judicial law or hereinafter granted. Product names used in this document may be trademarks or registered trademarks of their respective companies and are hereby acknowledged. All non-ELATION brands and product names are trademarks or registered trademarks of their respective companies.

ELATION PROFESSIONAL and all affiliated companies hereby disclaim all liabilities for property, equipment, building, and electrical damages, injuries to any persons, and direct or indirect economic loss associated with the use or reliance of any information contained within this document, and/or because of the improper, unsafe, insufficient, and negligent assembly, installation, rigging, and operation of this product.

Elation Professional USA | 6122 S. Eastern Ave. | Los Angeles, CA. 90040
323-582-3322 | 323-832-9142 fax | www.elationlighting.com | info@elationlighting.com

Elation Professional B.V. | Junostraat 2 | 6468 EW Kerkrade, The Netherlands
+31 45 546 85 66 | +31 45 546 85 96 fax | www.elationlighting.eu | info@elationlighting.eu

Elation Professional Mexico | AV Santa Ana 30 | Parque Industrial Lerma, Lerma, Mexico 52000
+52 (728) 282-7070

DOCUMENT VERSION



Due to additional product features and/or enhancements, an updated version of this document may be available online. Please scan the QR Code with your mobile device or visit www.elationlighting.com for the latest revision/update of this manual before installation and/or programming.

Date	Document Version	Software Version ≥	DMX Channel Modes	Notes
09/17/19	1.0	1.3.1	27 / 44	Initial release.
08/17/20	1.2	N/C	NO CHANGE	Updated thermal
10/06/20	1.4	N/C	NO CHANGE	Updated specifications
01/11/21	1.6	1.3.4	NO CHANGE	Updated sun protection
07/22/21	1.8	1.3.5	NO CHANGE	Added FIL dimensions, updated Software version to 1.3.5 to add Primary/Secondary
11/15/22	2.0	1.5	NO CHANGE	Updated System Menu, DMX Traits, and Truss Clamp information
03/07/23	2.1	2.01	No Change	Updated System Menu, DMX Traits, Fixture Transport and Handling
08/24/23	2.2	N/C	No Change	Removed Fixture Transport and Handling; updated Dimensional Drawings, Software Updates, Optional Accessories

CONTENTS

General Information	4
Limited Warranty (USA Only)	5
Safety Guidelines	6
Discharge Lamp Warning	8
Maintenance Guidelines	9
Fixture Overview	10
Colors, Gobos, Animation	11
Gobo Size	12
Gobo Replacement	13
Lamp Replacement	17
Fixture Installation	22
Sun Protection Mode Hibernation Mode	26
System Menu	27
Dimmer Mode	35
DMX Traits: Channel Functions and Values	36
Remote Device Management (RDM)	43
Software Updates	44
Error Codes	45
Specifications	46
Dimensional Drawings	47
Optional Accessories	49
FCC Statement	50

GENERAL INFORMATION

INTRODUCTION

Please read and understand the instructions in this manual carefully and thoroughly before attempting to operate this device. These instructions contain important safety and use information.

This device is intended for use by professionally trained personnel only, and so is not suitable for private use.

UNPACKING

Every device has been thoroughly tested and has been shipped in perfect operating condition. Carefully check the shipping carton for damage that may have occurred during shipping. If the carton is damaged, carefully inspect the device for damage, and be sure all accessories necessary to install and operate the device have arrived intact. In the event damage has been found or parts are missing, please contact our customer support team for further instructions. Please do not return this device to your dealer without first contacting customer support. Please do not discard the shipping carton in the trash. Please recycle whenever possible.

BOX CONTENTS

Omega Brackets (x2)
IP65 Power Cable

CUSTOMER SUPPORT

Contact **ELATION Service** for any product related service and support needs. Also visit forums.elationlighting.com with questions, comments or suggestions.

ELATION SERVICE USA - Monday - Friday 8:00am to 4:30pm PST
323-582-3322 | Fax 323-832-9142 | support@elationlighting.com

ELATION SERVICE EUROPE - Monday - Friday 08:30 to 17:00 CET
+31 45 546 85 63 | Fax +31 45 546 85 96 | support@elationlighting.eu

REPLACEMENT PARTS please visit parts.elationlighting.com

LIMITED WARRANTY (USA ONLY)

- A. Elation Professional hereby warrants, to the original purchaser, Elation Professional products to be free of manufacturing defects in material and workmanship for a period of two years (730 days), and Elation Professional product rechargeable batteries to be free of manufacturing defects in material and workmanship for a period of six months (180 days), from the original date of purchase. This warranty excludes discharge lamps and all product accessories. This warranty shall be valid only if the product is purchased within the United States of America, including possessions and territories. It is the owner's responsibility to establish the date and place of purchase by acceptable evidence, at the time service is sought.
- B. For warranty service, send the product only to the Elation Professional factory. All shipping charges must be pre-paid. If the requested repairs or service (including parts replacement) are within the terms of this warranty, Elation Professional will pay return shipping charges only to a designated point within the United States. If any product is sent, it must be shipped in its original package and packaging material. No accessories should be shipped with the product. If any accessories are shipped with the product, Elation Professional shall have no liability what-so-ever for loss and/or or damage to any such accessories, nor for the safe return thereof.
- C. This warranty is void if the product serial number and/or labels are altered or removed; if the product is modified in any manner which Elation Professional concludes, after inspection, affects the reliability of the product; if the product has been repaired or serviced by anyone other than the Elation Professional factory unless prior written authorization was issued to purchaser by Elation Professional; if the product is damaged because not properly maintained as set forth in the product instructions, guidelines and/or user manual.
- D. This is not a service contract, and this warranty does not include any maintenance, cleaning or periodic check-up. During the periods as specified above, Elation Professional will replace defective parts at its expense, and will absorb all expenses for warranty service and repair labor by reason of defects in material or workmanship. The sole responsibility of Elation Professional under this warranty shall be limited to the repair of the product, or replacement thereof, including parts, at the sole discretion of Elation Professional. All products covered by this warranty were manufactured after January 1, 1990, and bare identifying marks to that effect.
- E. Elation Professional reserves the right to make changes in design and/or performance improvements upon its products without any obligation to include these changes in any products theretofore manufactured.
- F. No warranty, whether expressed or implied, is given or made with respect to any accessory supplied with the products described above. Except to the extent prohibited by applicable law, all implied warranties made by Elation Professional in connection with this product, including warranties of merchantability or fitness, are limited in duration to the warranty periods set forth above. And no warranties, whether expressed or implied, including warranties of merchantability or fitness, shall apply to this product after said periods have expired. The consumer's and/or dealer's sole remedy shall be such repair or replacement as is expressly provided above; and under no circumstances shall Elation Professional be liable for any loss and/or damage, direct and/or consequential, arising out of the use of, and/or the inability to use, this product.
- G. This warranty is the only written warranty applicable to Elation Professional products and supersedes all prior warranties and written descriptions of warranty terms and conditions heretofore published.

WARRANTY RETURNS

All returned service items whether under warranty or not, must be freight pre-paid and accompany a return authorization (R.A.) number. The R.A. number must be clearly written on the outside of the return package. A brief description of the problem as well as the R.A. number must also be written down on a piece of paper and included in the shipping container. If the unit is under warranty, you must provide a copy of your proof of purchase invoice. Items returned without a R.A. number clearly marked on the outside of the package will be refused and returned at customer's expense. You may obtain a R.A. number by contacting customer support.

SAFETY GUIDELINES

This fixture is a sophisticated piece of electronic equipment. To guarantee a smooth operation, it is important to follow all instructions and guidelines in this manual. Elation Professional is not responsible for injury and/or damages resulting from the misuse of this fixture due to the disregard of the information printed in this manual. Only qualified and/or certified personnel should perform installation of this fixture and only the original rigging parts (omega brackets) included with this fixture should be used for installation. Any modifications to the fixture and/or the included mounting hardware will void the original manufactures warranty and increase the risk of damage and/or personal injury.



PROTECTION CLASS 1 - FIXTURE MUST BE PROPERLY GROUNDED



**THERE ARE NO USER SERVICEABLE PARTS INSIDE THIS UNIT.
DO NOT ATTEMPT ANY REPAIRS YOURSELF; DOING SO WILL VOID YOUR MANUFACTURES WARRANTY. DAMAGES RESULTING FROM MODIFICATIONS TO THIS FIXTURE AND/OR THE DISREGARD OF SAFETY INSTRUCTIONS AND GUIDELINES IN THIS MANUAL VOID THE MANUFACTURES WARRANTY AND ARE NOT SUBJECT TO ANY WARRANTY CLAIMS AND/OR REPAIRS.**



**DO NOT PLUG FIXTURE INTO A DIMMER PACK!
NEVER OPEN THIS FIXTURE WHILE IN USE!
UNPLUG POWER BEFORE SERVICING FIXTURE!
NEVER TOUCH FIXTURE DURING OPERATION, AS IT MAY BE HOT!
KEEP FLAMMABLE MATERIALS AWAY FROM FIXTURE!**



**NEVER LOOK DIRECTLY INTO THE LIGHT SOURCE!
RETINA INJURY RISK - MAY INDUCE BLINDNESS!
SENSITIVE PERSONS MAY SUFFER AN EPILEPTIC SHOCK!**



**INDOOR / DRY LOCATIONS USE ONLY!
DO NOT EXPOSE FIXTURE TO RAIN AND MOISTURE!**



**MINIMUM DISTANCE TO OBJECTS/SURFACES
MUST BE 49.2 FEET (15 METERS)
MAXIMUM TEMP OF EXTERNAL SURFACE 248°F (120°C)
MINIMUM DISTANCE OF INFLAMMABLE MATERIALS
FROM THE SURFACE 1.6 FEET (0.5 METER)**

SAFETY GUIDELINES

CAUTION

**HIGH
INTENSITY
ULTRAVIOLET
LIGHT**



AVOID DIRECT EYE & SKIN EXPOSURE.
WEAR PROPER EYE & SKIN PROTECTION.
SEE MANUAL FOR SAFETY INSTRUCTIONS.

RISK GROUP 3 - RISK OF EXPOSURE TO ULTRAVIOLET UV RADIATION! FIXTURE EMITS HIGH INTENSITY WAVELENGTH OF ULTRAVIOLET UV LIGHT FROM THE UV COLOR FILTER. WEAR PROPER EYE AND SKIN PROTECTION. AVOID PROLONGED PERIODS OF EXPOSURE TO UV COLOR FILTER. AVOID WEARING WHITE COLOR CLOTHING AND/OR USING UV PAINTS ON SKIN. AVOID DIRECT EYE AND/OR SKIN EXPOSURE AT DISTANCES LESS THAN 11 feet (3.3m). DO NOT OPERATE FIXTURE WITH DAMAGED/MISSING EXTERNAL COVERS. DO NOT LOOK DIRECTLY

INTO THE UV LIGHT AND/OR VIEW UV LIGHT DIRECTLY WITH OPTICAL INSTRUMENTS THAT MAY CONCENTRATE THE LIGHT/RADIATION OUTPUT. INDIVIDUALS SUFFERING FROM A RANGE OF EYE CONDITIONS, SUNLIGHT EXPOSURE DIS-ORDERS, OR INDIVIDUALS USING PHOTOSENSITIVE MEDICATION, MAY RECEIVE DISCOMFORT IF EXPOSED TO THE ULTRAVIOLET UV LIGHT EMITTED FROM THE UV LED.

DO NOT TOUCH the fixture housing during operation. Turn OFF the power and allow approximately 60 minutes for the fixture to cool down before serving.

DO NOT shake fixture, avoid brute force when installing and/or operating fixture.

DO NOT operate fixture if the power cord is frayed, crimped, damaged and/or if any of the power cord connectors are damaged and do not insert into the fixture securely with ease. **NEVER** force a power cord connector into the fixture. If the power cord or any of its connectors are damaged, replace it immediately with a new one of similar power rating.

DO NOT block any air ventilation slots.

All fan and air inlets must remain clean and never blocked.

Allow approx. 6" (15cm) between fixture and other devices or a wall for proper cooling.

Always disconnect fixture from main power source before performing any type of service and/or cleaning procedure. Only handle the power cord by the plug end, never pull out the plug by tugging the wire portion of the cord.

During the initial operation of this fixture, a light smoke or smell may emit from the interior of the fixture. This is a normal process and is caused by excess paint in the interior of the casing burning off from the heat associated with the lamp and will decrease gradually over time.

Consistent operational breaks will ensure fixture will function properly for many years.

ONLY use the original packaging and materials to transport the fixture in for service.

DISCHARGE LAMP WARNING

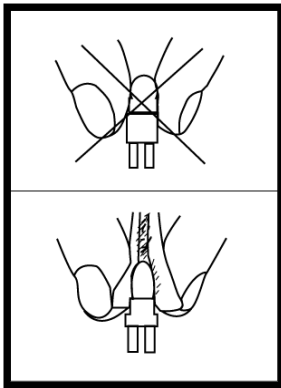

This fixture is fitted with a DISCHARGE LAMP, which is highly susceptible to damage if improperly handled. NEVER touch the lamp with your bare hands, as the oil from your hands will shorten the life of the lamp. **NEVER** move the fixture until the lamp has had ample time to cool. DISCHARGE LAMPS are NOT covered under warranty conditions. Avoid switching the fixture ON and OFF repeatedly in short intervals, as this will reduce lamp life and intensity. To achieve the intensity associated with discharge lamps, these lamps use gas sealed in a high-pressure environment to emit a brilliant output.

Due to the high pressure involved with the construction of the lamp, it **MAY EXPLODE DURING PROLONGED EXTENSIVE USE**. This risk is increased with age; added care is encouraged when dealing with older lamps. Thus, the lamp must always be replaced at the end of their recommended duty cycle. Extreme caution should be used when operating this or any fixture fitted with a gas discharge lamp.

UV RADIATION NOTICE



THIS FIXTURE EMITS INTENSE UV RADIATION, WHICH IS HARMFUL TO THE EYES AND SKIN. THE INTENSE LUMINANCE OF THE LAMP CAN CAUSE SEVERE DAMAGE TO THE RETINA. NEVER OPERATE THIS FIXTURE WITH ANY OF THE PROTECTIVE COVERS REMOVED. THESE COVERS HAVE BEEN SPECIALLY DESIGNED TO SHIELD AGAINST UV RADIATION.

LAMP REPLACEMENT



USE ONLY GENUINE ORIGINAL PHILIPS™ LAMPS. OTHER BRAND LAMPS WILL CAUSE DAMAGE AND WILL VOID FIXTURE WARRANTY!

**DISCONNECT THE MAIN POWER SUPPLY BEFORE REPLACING LAMP!
FIXTURE MUST COOL FOR 60 MINUTES BEFORE REPLACING LAMP!**

**NEVER TOUCH LAMP WITH BARE HANDS, ALWAYS WEAR GLOVES!
OIL FROM HANDS WILL SHORTEN LIFE OF LAMP!**

MAKE SURE ALL COVERS/PANELS ARE REPLACED/SECURED BEFORE OPERATING FIXTURE TO PREVENT ANY RISK AND/OR DAMAGE TO EYE RETINA FROM UV RADIATION EXPOSURE!

MAINTENANCE GUIDELINES



DISCONNECT POWER BEFORE PERFORMING ANY MAINTENANCE!

CLEANING

Frequent cleaning is recommended to insure proper function, optimized light output, and an extended life. The frequency of cleaning depends on the environment in which the fixture operates: damp, smoky or particularly dirty environments can cause greater accumulation of dirt on the fixture's optics. Clean the external lens surface at least every 20 days with a soft cloth to avoid dirt/debris accumulation.

NEVER use alcohol, solvents, or ammonia-based cleaners.

MAINTENANCE

Regular inspections are recommended to insure proper function and extended life.

There are no user serviceable parts inside this fixture, please refer all other service issues to an authorized Elation service technician. Should you need any spare parts, please order genuine parts from your local Elation dealer.

Please refer to the following points during routine inspections:

- A detailed electric check by an approved electrical engineer every three months, to make sure the circuit contacts are in good condition and prevent overheating.
- Be sure all screws and fasteners are securely tightened at all times. Loose screws may fall out during normal operation resulting in damage or injury as larger parts could fall.
- Check for any deformations on the housing, color lenses, rigging hardware and rigging points (ceiling, suspension, trussing). Deformations in the housing could allow for dust to enter into the fixture.
- Damaged rigging points or unsecured rigging could cause the fixture to fall and seriously injure a person(s).
- Electric power supply cables must not show any damage, material fatigue or sediments. **NEVER** remove the ground prong from the power cable.

FIXTURE OVERVIEW

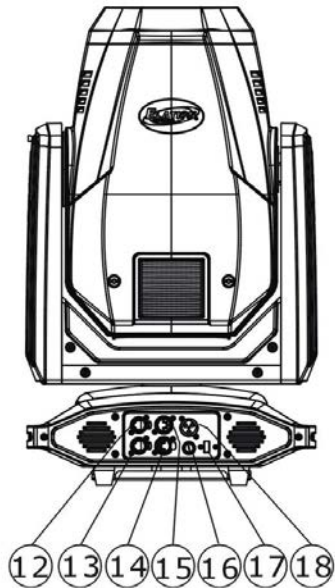
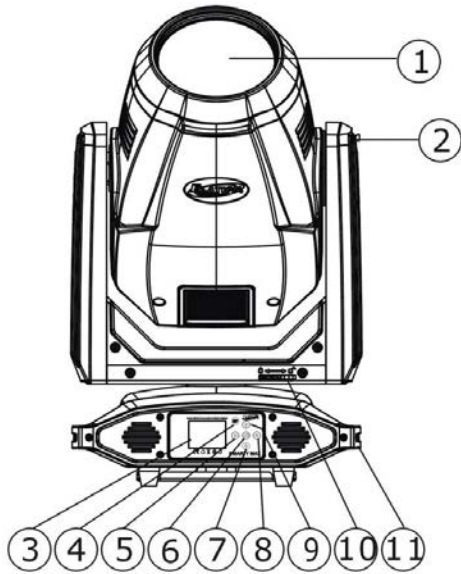

1. Lens
2. TILT Lock
3. LCD Control Menu Display
4. MODE/ESC Button
5. LEFT Button
6. ENTER Button
7. DOWN Button
8. RIGHT Button
9. UP Button
10. PAN Lock
11. Handle (s)
12. RJ45 Ethernet IN
13. RJ45 Ethernet OUT
14. 5pin DMX OUT
15. 5pin DMX IN
16. Fuse
17. Service Port
18. Power IN

SAFETY CABLE ATTACHMENT



ALWAYS ATTACH A SAFETY CABLE WHENEVER INSTALLING THIS DEVICE IN A SUSPENDED ENVIRONMENT TO ENSURE THE FIXTURE WILL NOT DROP IF THE CLAMP FAILS.

COLORS, GOBOS, ANIMATION

Color Wheel	Color Flags
Red	Cyan
Green	Magenta
Yellow	Yellow
Purple	
Cyan	
Orange	
Magenta	
Light Green	
Pink	
UV Filter	
CTB	
CTO	
Blue	

INTERCHANGEABLE-ROTATING GLASS GOBO WHEEL 1

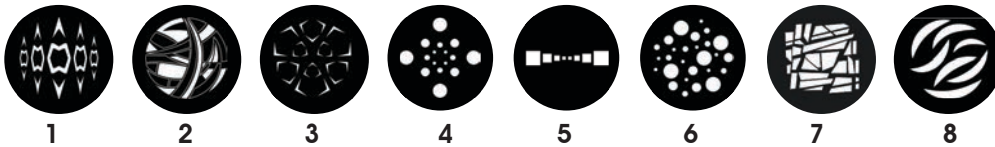

STATIC-FIXED METAL GOBO WHEEL 2

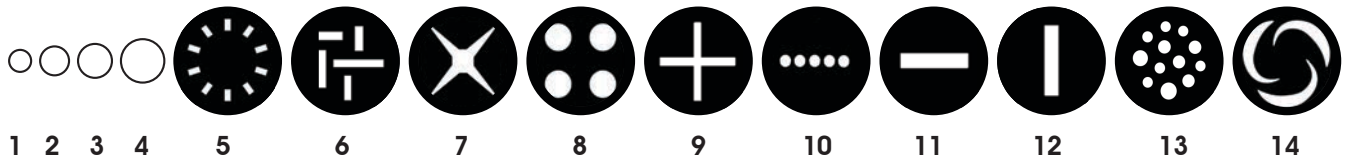

BI-DIRECTIONAL ANIMATION WHEEL



GOBO SIZE

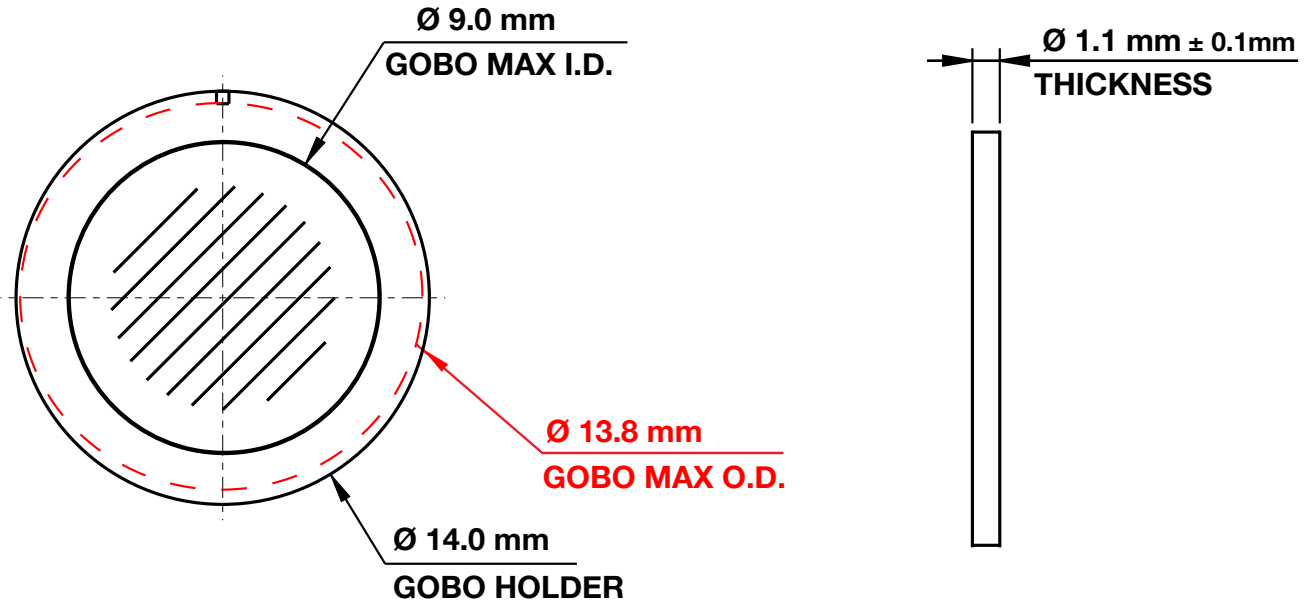

ROTATING GLASS GOBOS - WHEEL 1	
Gobo O.D. (Max. Outer Diameter)	Ø 13.8mm
Gobo I.D. (Max. Image Diameter)	Ø 9.0mm
Gobo Holder Diameter	Ø 14.0mm
Gobo Thickness	Ø 1.1mm ±0.1mm
Gobo Material	BOROFLOAT GLASS

***** IMPORTANT NOTICE REGARDING CUSTOM GOBOS *****

Due to the high temperature optical system, special material as listed above is required for custom gobos. Due to varying manufacturing processes and tolerances, it is highly recommended to provide a gobo sample and holder from the fixture to the custom gobo vendor for accurate sizing. Extended testing of custom gobo designs is highly recommended prior to use. Contact ELATION SERVICE for further information.

ELATION SERVICE USA - Monday - Friday 8:00am to 5:00pm PST
 Voice: 323-582-3322 Fax: 323-832-9142
 E-mail: support@elationlighting.com

ELATION SERVICE EUROPE - Monday - Friday 08:30 to 17:00 CET
 Voice: +31 45 546 85 30 Fax: +31 45 546 85 96
 E-mail: support@elationlighting.eu

GOBO REPLACEMENT



1. Before removing covers, place fixture on a stable flat surface in an **INDOOR DUST FREE** location. Ensure moving head is locked into a neutral upright position with both PAN and TILT locks engaged.

2. Unfasten and remove the front and back panels; each are secured with (2x) ¼-turn Phillips-head screws. (These screws are integrally installed in both panels and cannot be removed.) With the panel screws unfastened, unclip their safety cables to remove them completely from the fixture. For safety and ease of access, the fixture can be locked at a 45° angle.

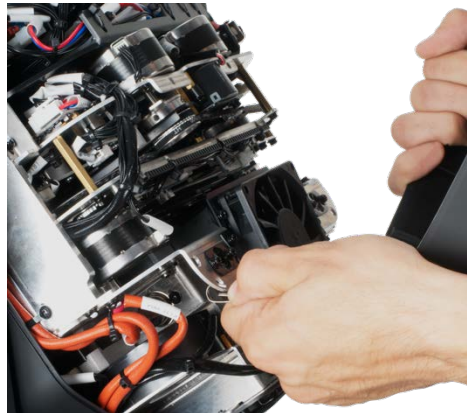

GOBO REPLACEMENT

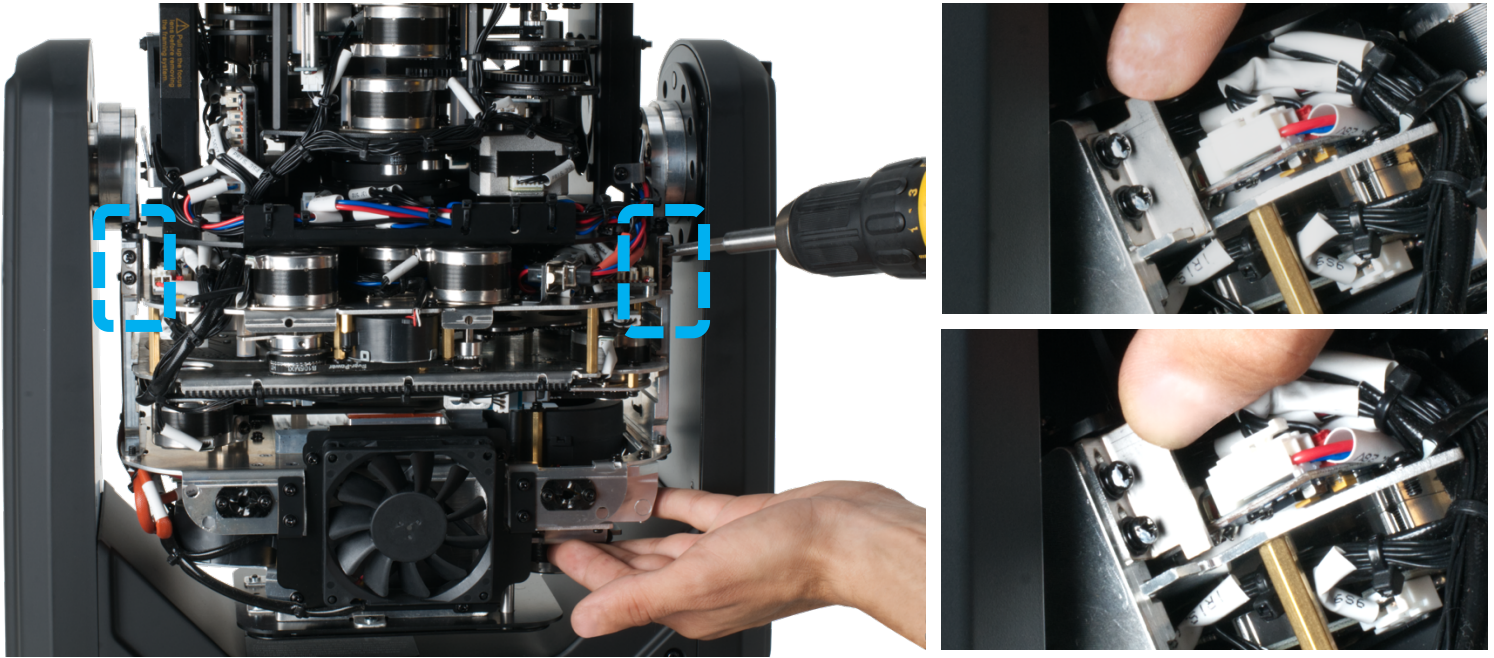

3. Locate the two slotted brackets which secure the GOBO Wheel Module to the frame, each held with two Phillips-head screws. Loosen the (4x) Phillips-head screws, which will allow the slotted brackets to slide up. Slide the two slotted brackets up as shown above right.

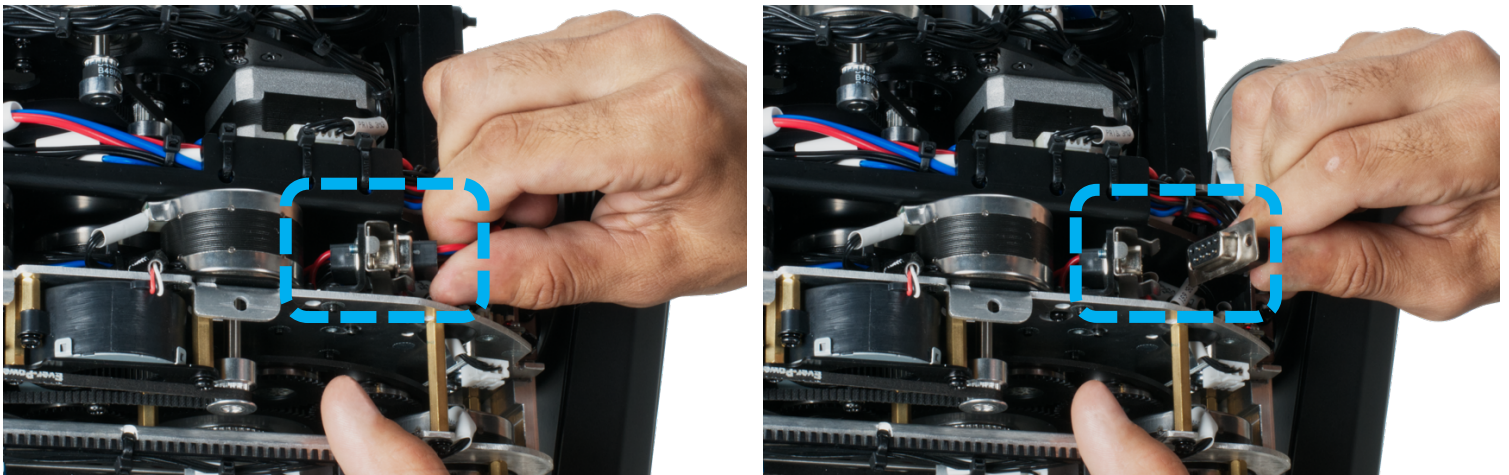

4. Locate the 9-pin GOBO Wheel Module connector and carefully unplug it from the connector base.



CAUTION! DO NOT USE FORCE TO REMOVE CONNECTOR!

GOBO REPLACEMENT



5. Impeding the removal of the GOBO Wheel Module is the Zoom Lens, which is set within the lens housing aperture. Position the moving head down so the lens is facing down as well. This will allow gravity to drop the Zoom Lens out of the aperture. With the Zoom Lens dropped out of the way, carefully grip the GOBO Wheel Module, and slide it out and away to clear the mounting rails, and then carefully place the module on a stable flat surface in an **INDOOR DUST FREE** location.

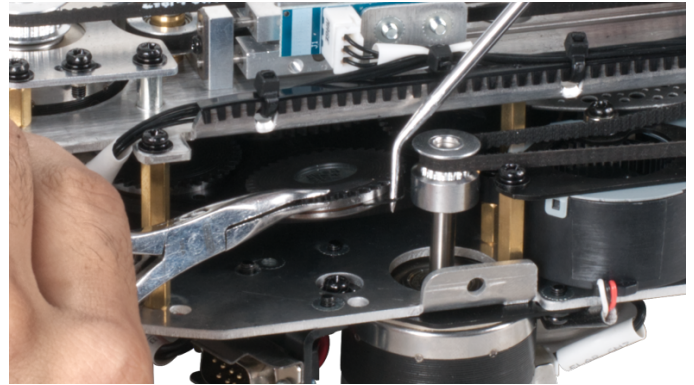
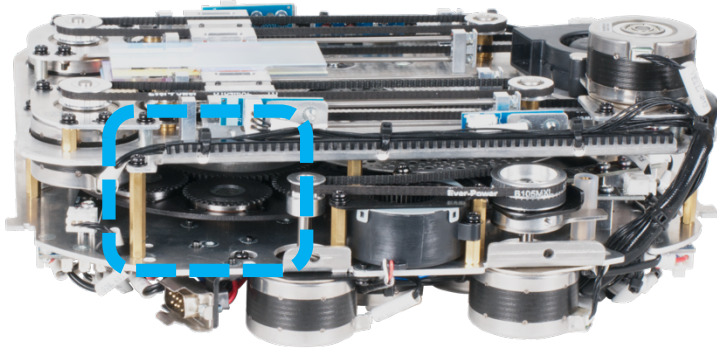

6. REPLACING A ROTATING GOBO

Locate the specific Rotating GOBO to replace. Carefully grip the GOBO Holder using needle nose pliers (or equivalent) and the ring/tab with a precision pick (or equivalent) and gently lift it slightly to pull it out and away until it fully clears the GOBO Wheel.



GOBO REPLACEMENT

7. REPLACING A ROTATING GOBO

Locate the tab of the spring, and with a precision pick (or similar tool), carefully press retaining spring inward to relieve tension.



8. Remove the retaining spring and carefully separate the GOBO from the GOBO Holder. Install the replacement Rotating GOBO following the steps above in reverse order.



CAUTION: TAKE CARE NOT TO SCRATCH GOBO OR GOBO HOLDER!

LAMP REPLACEMENT

To ensure a proper/safe lamp change, carefully read all the following instructions.

USE ONLY GENUINE ORIGINAL PHILIPS™ LAMPS. OTHER BRAND LAMPS WILL CAUSE DAMAGE AND WILL VOID FIXTURE WARRANTY!



**DISCONNECT THE MAIN POWER SUPPLY BEFORE REPLACING LAMP!
FIXTURE MUST COOL FOR 60 MINUTES BEFORE REPLACING LAMP!**

**NEVER TOUCH LAMP WITH BARE HANDS, ALWAYS WEAR GLOVES!
OIL FROM HANDS WILL SHORTEN LIFE OF LAMP!**

MAKE SURE ALL COVERS/PANELS ARE REPLACED/SECURED BEFORE OPERATING FIXTURE TO PREVENT ANY RISK AND/OR DAMAGE TO EYE RETINA FROM UV RADIATION EXPOSURE!

LAMP PROTECTION CIRCUITRY

The fixture LCD Menu Control Display will indicate the lamp life and related lamp warnings with each power ON, each lamp strike, and when specific lamp hours are reached. The table below provides details on each lamp life warning. Due to the extreme heat associated with the lamp and the nature of the internal optical system, it is **IMPERATIVE** the lamp is replaced when the LCD Menu Control Display indicates replacement is needed. This is done to protect the internal optical system as well as prevent accidental lamp explosion, which could lead to hot glass particles falling from the fixture.

Total Lamp Hours = X – 20%

LCD display will slowly blink with a YELLOW outline and the following warning for 10 mins:
“LAMP LIFE left “X” hours. Please change lamp soon”

Sending a DMX value of 250-251 in Channel 24 (Standard Mode) or Channel 34 (Extended Mode) from the lighting controller or pressing the OK button on the fixture control panel will clear this warning.

Total Lamp Hours = X up to X + 20%

LCD display will slowly blink with a RED outline and the following warning for 10 mins:
“LAMP LIFE exceeded by “X” hours. Please change lamp immediately”

Sending a DMX value of 250-251 in Channel 24 (Standard Mode) or Channel 34 (Extended Mode) from the lighting controller or pressing the OK button on the fixture control panel will clear this warning.

Total Lamp Hours = X + 20% and higher

LCD display will slowly blink RED Outline and the following warning:

“Lamp Life “X” hours. Danger of lamp explosion and permanent fixture damage. Replace lamp immediately! User assumes all risks”

This error can ONLY be cleared when the lamp hours are reset.

LAMP REPLACEMENT

LAMP LIFE OF PHILIPS PLATINUM 400L FLEX = UP TO 4,000 HOURS

Lamp hours are calculated in real time by a smart algorithm combining periods of full output and periods of hibernation with the shutter closed. To reach 4,000 hours the fixture must be operated in average entertainment usage patterns that contain cycles of closed shutters to enter hibernation mode. On average this will allow to the fixture to reach 4,000 hours under common entertainment operation cycles as defined by Philips as 30% operation, 70% hibernation. In the rare case that the fixture Smarty would be turned on, shutter opened and never closed again the lamp life is 1,500 hours. Lamp life idle, total time and an estimated total lamp life % are provided in the display of the fixture.

LAMP INSTALLATION PROCEDURE

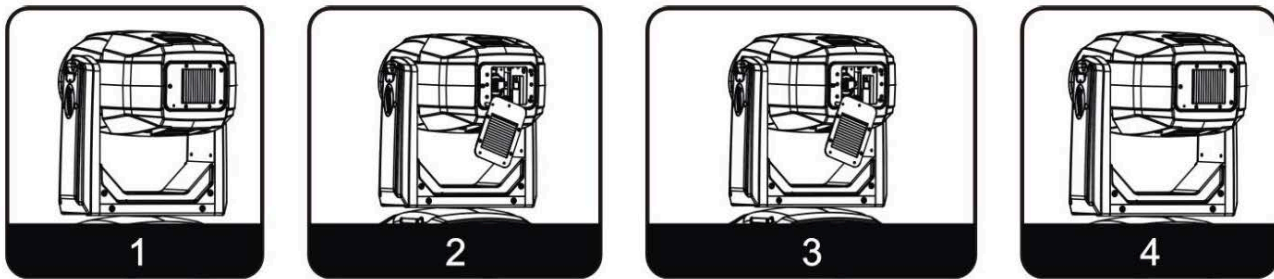

WARNING!

LAMP REPLACEMENT SHOULD ONLY BE DONE BY A TRAINED TECHNICIAN.

1. Turn OFF power and allow approximately **60 minutes** for the fixture to cool down.
2. Place fixture on a stable flat surface in an **INDOOR DUST FREE** location, and position moving head into a 90 degree position with both PAN and TILT locks engaged.
3. Remove (3) Philips-head screws marked "A", "B", and "C" to remove lamp access panel.

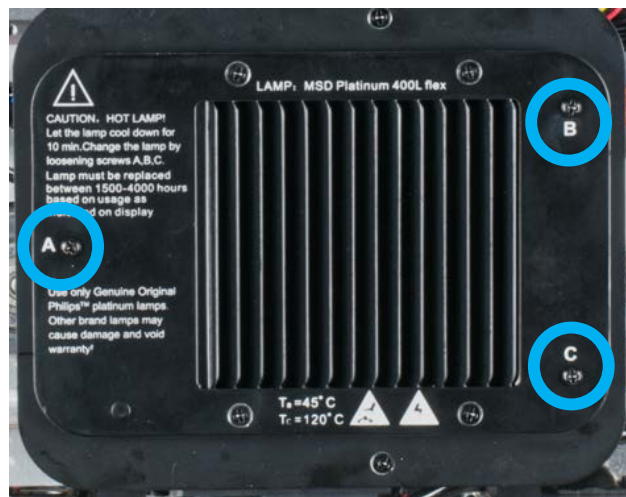

LAMP REPLACEMENT

LAMP INSTALLATION PROCEDURE

4. Remove the (2x) spade receptacle-terminals connected to the lamp base.

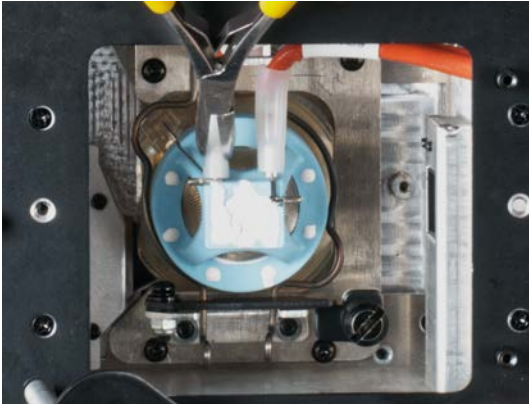

5. Loosen the large black slotted screw holding down the hinged lamp retention clip bar. Pull the bar out away and push to the side.

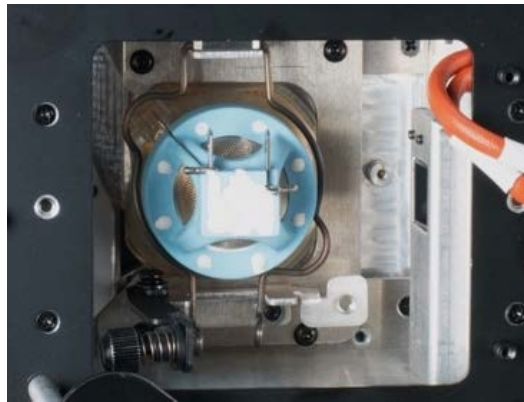
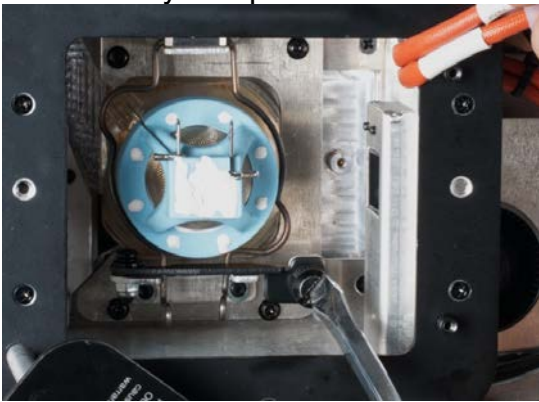

6. Squeeze the retention clip and pull clip up and away from the lamp.

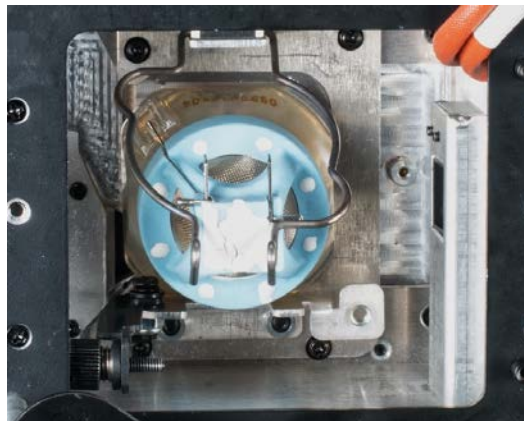

LAMP REPLACEMENT

LAMP INSTALLATION PROCEDURE

7. Gently grab lamp base with thumb and index finger and pull lamp out from fixture.

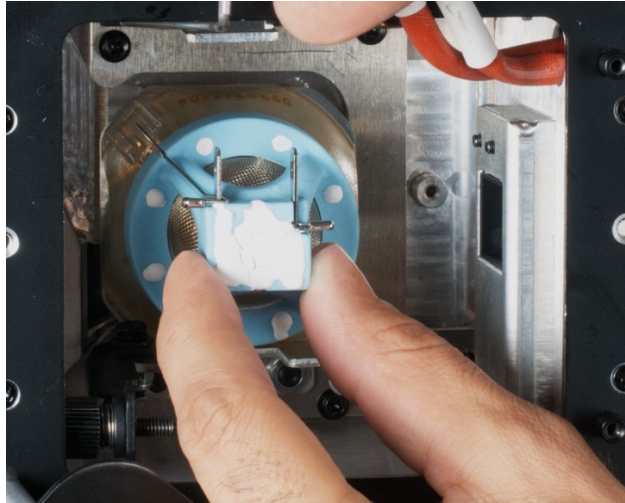

8. Using thumb and index finger, gently install the new lamp. Position lamp so it is seated properly, then swing down the retention clip, squeezing the ends to lock/secure the lamp into place.
9. Brush away any debris as this could compromise fixture performance.



10. Gently attach (2x) spade receptacle-terminals securely to the base of the lamp.
11. Replace lamp access panel and secure (3) Philips-head screws marked “A”, “B”, and “C”.
12. Be sure to reset the **LAMP HOURS** in the system menu to prevent the protection circuitry from accidentally shutting off the lamp during normal operation. If the lamp protection circuitry has already been initiated and the **LAMP HOURS** is not reset, the “**Replace the Lamp**” warning will continue to flash, and fixture will eventually shut down. To reset **LAMP HOURS**, see instructions on the next page.

LAMP REPLACEMENT

LAMP HOURS RESET PROCEDURE

1. Activate the main menu by pressing **MODE/ESC** and toggle to “**Information**”.
2. Press **ENTER** and press **UP** or **DOWN** to toggle to “**Time Information**”.
3. Press **UP** or **DOWN** to toggle to “**LampTime Password**” and press **ENTER**.

Press **UP** or **DOWN** to enter the reset pass code, “**038**” and press **ENTER** to confirm. The display will automatically revert to “**LampTime Password**”, next press **UP** or **DOWN** to toggle down to “**Clean Lamp Time**”.

4. Press **ENTER** and select “**ON**”. The lamp timer has now been reset, press **MODE/ESC** to exit the menu and return to the home screen.

LAMP OPTIMIZATION

Unlike traditional discharge lamps the **Philips MSD Platinum 400L FLEX** lamp does **NOT** require optimization. The lamp orientation and optimization procedure has been preset during the manufacturing process of the lamp. The lamp is **NOT** a hot-restrike lamp therefore, you must wait approximately **10 minutes** before attempting to restrike once it has been turned off.

FIXTURE INSTALLATION



FLAMMABLE MATERIAL WARNING

Keep fixture minimum 5.0 feet (1.5m) away from flammable materials and/or pyrotechnics.



ELECTRICAL CONNECTIONS

A qualified electrician should be used for all electrical connections and/or installations.



MINIMUM DISTANCE TO OBJECTS/SURFACES MUST BE 49.2 FEET (15 METERS)



MINIMUM DISTANCE OF INFLAMMABLE MATERIALS FROM THE SURFACE 1.6 FEET (0.5 METER)



MAXIMUM TEMP OF EXTERNAL SURFACE 248° F (120°C)



DO NOT INSTALL THE FIXTURE IF YOU ARE NOT QUALIFIED TO DO SO!

Fixture **MUST** be installed following all local, national, and country commercial electrical and construction codes and regulations.

Before rigging/mounting a single fixture or multiple fixtures to any metal truss/structure or placing the fixture(s) on any surface, a professional equipment installer **MUST** be consulted to determine if the metal truss/structure or surface is properly certified to safely hold the combined weight of the fixture(s), clamps, cables, and accessories.

Overhead rigging requires extensive experience, including amongst others calculating working load limits, installation material being used, and periodic safety inspection of all installation material and the fixture. If you lack these qualifications, do not attempt the installation yourself. Improper installation can result in bodily injury.

Fixture ambient operating temperature range is **14° to 113°F. (-10° to 45°C)**

Do not use the fixture under or above this temperature.

Fixture(s) should be installed in areas outside walking paths, seating areas, or away from areas where unauthorized personnel might reach the fixture by hand.

NEVER stand directly below the fixture(s) when rigging, removing, or servicing.

Overhead fixture installation must always be secured with a secondary safety attachment, such as an appropriately rated safety cable.

Allow approximately **60 minutes** for the fixture to cool down before serving.

FIXTURE INSTALLATION

OMEGA BRACKETS INSTALLATION

Insert the Omega Brackets into the matching holes on the bottom of the fixture. Note that there are 8 possible locations. Secure the Omega Brackets to the fixture by turning each quick-lock fastener ¼ turn clockwise; making sure the fastener is completely locked. Omega Brackets can be installed into the fixture base as illustrated below.

Omega Bracket Mounting Holes

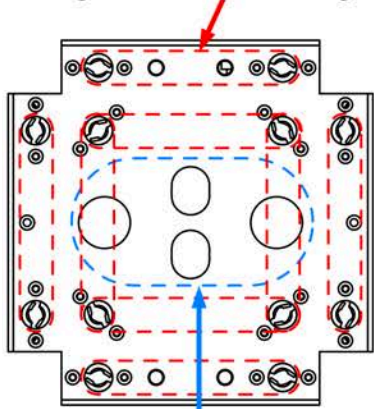

Safety Cable Rigging Points

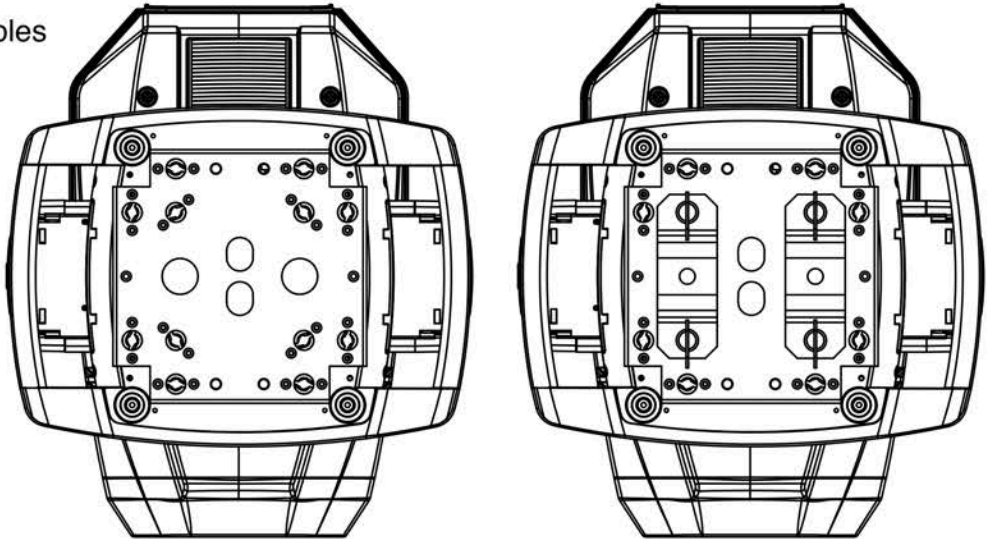

CLAMP INSTALLATION

When mounting fixture to truss, be sure to secure an appropriately rated professional grade rigging clamp to the included **Omega Brackets** using an M12 screw fitted through the center hole of the **Omega Brackets**. The fixture provides a built-in rigging point for a **SAFETY CABLE**. Be sure to only use one of the designated rigging points for the safety cable and never secure a safety cable to a carrying handle.

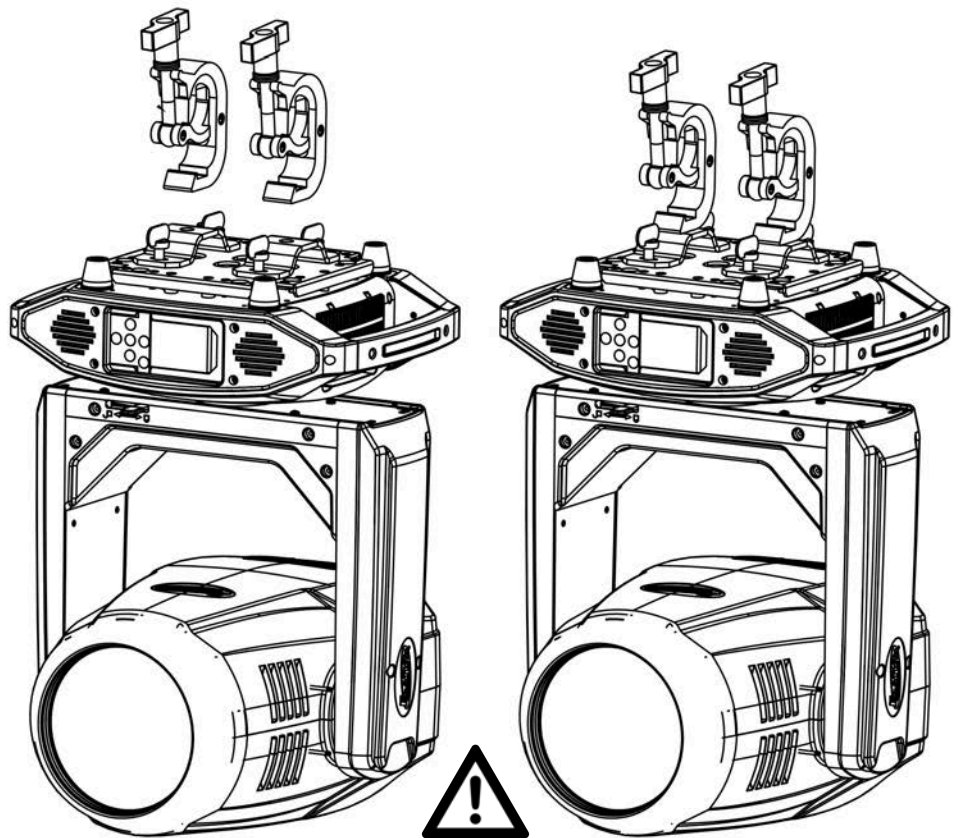

ALWAYS ATTACH AN APPROPRIATELY RATED SAFETY CABLE (NOT INCLUDED) THAT MEETS ALL LOCAL, NATIONAL, AND COUNTRY CODES AND REGULATIONS WHENEVER INSTALLING FIXTURE IN A SUSPENDED ENVIRONMENT!

FIXTURE INSTALLATION

RIGGING

Overhead rigging requires extensive experience, including among others calculating working load limits, installation material being used, and periodic safety inspection of all installation material and the fixture. If you lack these qualifications, do not attempt the installation yourself. Improper installation can result in bodily injury.

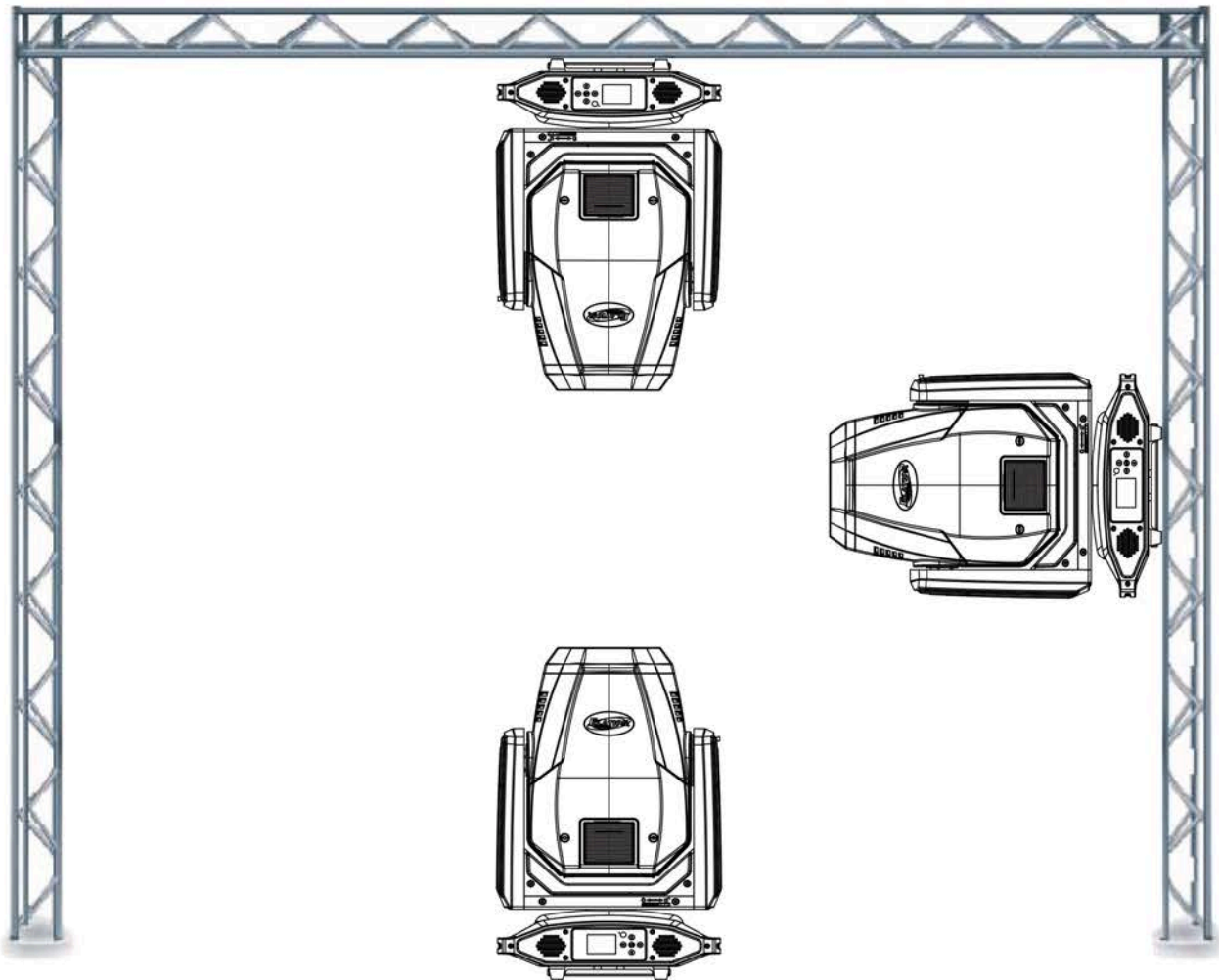

FIXTURE INSTALLATION

ART-NET | sACN CONNECTION

When connecting fixture to a network switch to control multiple devices, a **Gigabit Ethernet Switch** that supports **IGMP (Internet Group Management Protocol)** is required. Using a **Gigabit Ethernet Switch** that does not support **IGMP** can cause erratic behavior of all connected devices to the switch. Click link below for more information about IGMP.

https://en.wikipedia.org/wiki/Internet_Group_Management_Protocol

POTENTIAL INTERNAL FIXTURE DAMAGE FROM EXTERNAL SOURCES OF LIGHT BEAMS

External sources of light beams from direct sunlight, lighting moving head fixtures, and lasers, which are focused directly on the exterior housing and/or penetrate the front lens opening of ELATION lighting fixtures, can cause severe internal damage including burning to optics, dichroic color filters, glass and metal gobos, prisms, animation wheels, frost filters, iris, shutters, motors, belts, wiring, discharge lamps, and LEDs.

This issue is not specific only to ELATION lighting fixtures, it is a common issue with lighting fixtures from all manufacturers. Although there is no true way to fully prevent this issue from happening, the guidelines below can prevent any potential damage from occurring if followed. Contact ELATION Service for more details.

DO NOT EXPOSE THE FIXTURE AND/OR FRONT LENS OPENING TO LIGHT BEAMS FROM DIRECT SUNLIGHT, OTHER LIGHTING MOVING HEAD FIXTURES, AND LASERS WHILE UNPACKING, INSTALLATION, USE, AND EXTENDED IDLE TIMES OUTDOORS. DO NOT FOCUS A LIGHT BEAM FROM ONE LIGHTING FIXTURE DIRECTLY TOWARDS ANOTHER.

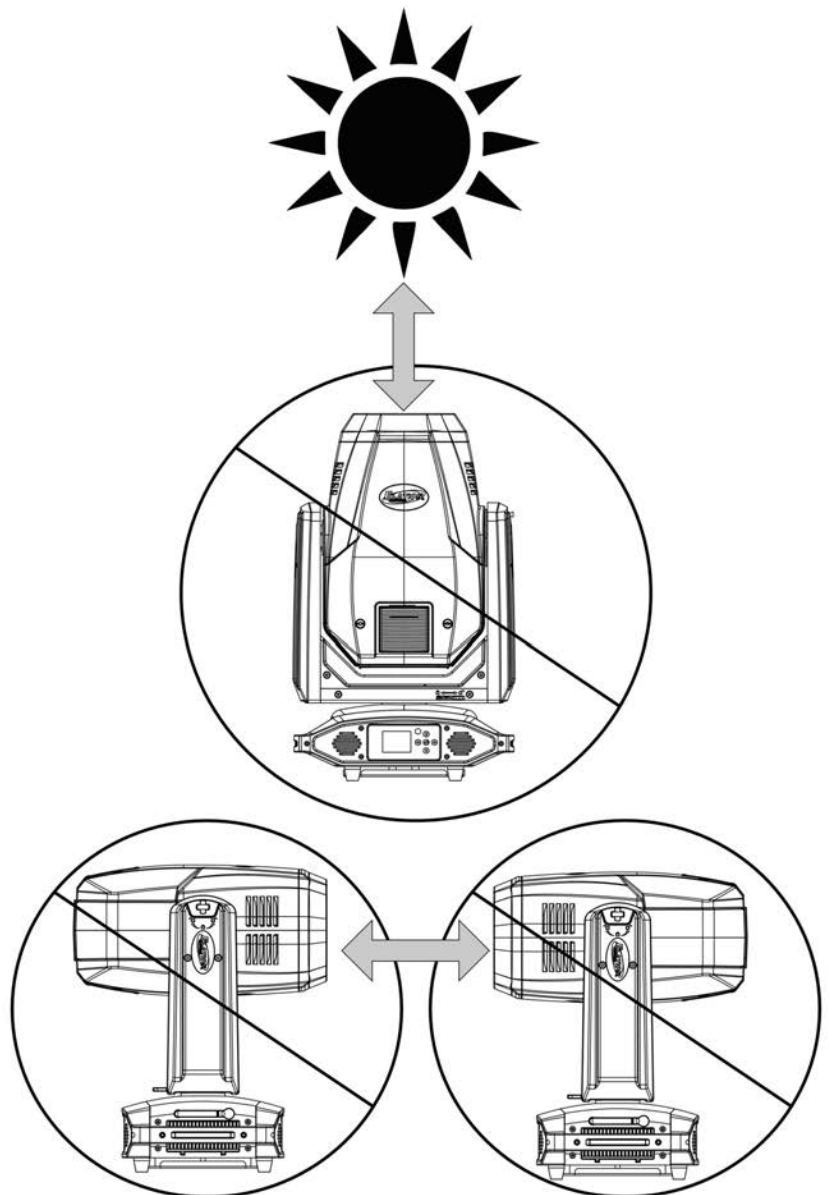

SUN PROTECTION MODE

The fixture incorporates an automatic protection from harmful sunlight, which can damage a fixture's internal components from extended exposure. Fixtures use an internal sensor to determine their physical orientation, then reorient the fixture towards the ground to prevent sunlight from entering the lens.

This automatic feature only works when the fixture is powered. If the fixture is unpowered during setup, it is necessary to manually reorient the lenses away from the sun and aim them towards the ground. Even a few minutes of sun exposure can cause damage inside the fixture.

The Sun Protection setting is accessed via the "No DMX Status" menu.

The automatic sun protection positioning is activated under the following conditions:

1. Power on without DMX signal: the fixture always starts in sun protection mode.
2. No DMX Status "Sun Protection": the fixture enters sun protection mode after approximately 3 minutes.
3. Remote DMX control: the sun protection position can be temporarily activated from the lighting console without the need to create a custom position preset. The fixture senses the correct ground orientation. This means that fixtures already facing the ground may not move their heads.

Hold "Sun Protect Position" for 3s to set the fixture to the sun protection position.

Sun protection status displays as "**Sun Protection: Active**".

The sun protection position deactivates under the following conditions:

1. Connect DMX signal.
2. Remote DMX control: Hold "Sun Protection Off" for 3s.

To avoid harsh or jarring movements, the sun protection position always uses a 5-second fade time when it is activated or deactivated.

HIBERNATION MODE

To reduce wear on the fixture and its components, this mode disables motors and most electronics. Set the hibernation mode countdown time in the Display Menu: "Status Settings / Personality / Hibernation". Hibernation can be fully disabled.

The hibernation mode activates under the following conditions:

1. Loss of DMX: the fixture enters hibernation after the timeout expires. Default is 15 minutes.
2. Remote DMX control: Hold "Hibernate Fixture" for 3s

The hibernation mode deactivates under the following conditions:

1. Connect DMX Signal
2. Remote DMX control: Hold "Hibernate Off" for 3s

The fixture will perform a full calibration cycle, then assume the current DMX status.

Please note that the Hibernation does not change the PT position of the fixtures, allowing the user to set the desired position and then issue the Hibernate command.

To ensure the fixture is protected from harmful sunrays it is recommended to either leave the "No DMX Status" in "Sun Protection" (so the fixture is already in the correct position after 3 minutes of DMX loss) or set the fixture to a safe Tilt position manually first before hibernation.

Burn and heat damage to the fixture's interior components due to external light sources (sun or other fixtures shining into the lens) is never covered under the manufacturer's warranty.

SYSTEM MENU

The fixture includes an easy to navigate system menu. The control panel (see image below) located on the front of the fixture, provides access to the main system menu and is where all necessary system adjustments are made to the fixture. During normal operation, pressing **MODE/ESC** button once will access the fixture's main menu. Once in the main menu you can navigate through the different functions and access the sub-menus with the **UP**, **DOWN**, **RIGHT**, and **LEFT** buttons. Once you reach a field that requires adjusting, press the **ENTER** button to activate that field and use the **UP** and **DOWN** buttons to adjust the field. Pressing the **ENTER** button once more will confirm your setting. You may exit the main menu at any time without making any adjustments by pressing the **MODE/ESC** button.

To access the LCD Menu Control Display via the internal battery, press and hold the **MODE/ESC** button for 5 seconds. The LCD Menu Control Display will shut **OFF** automatically about 1 minute from the last button press.

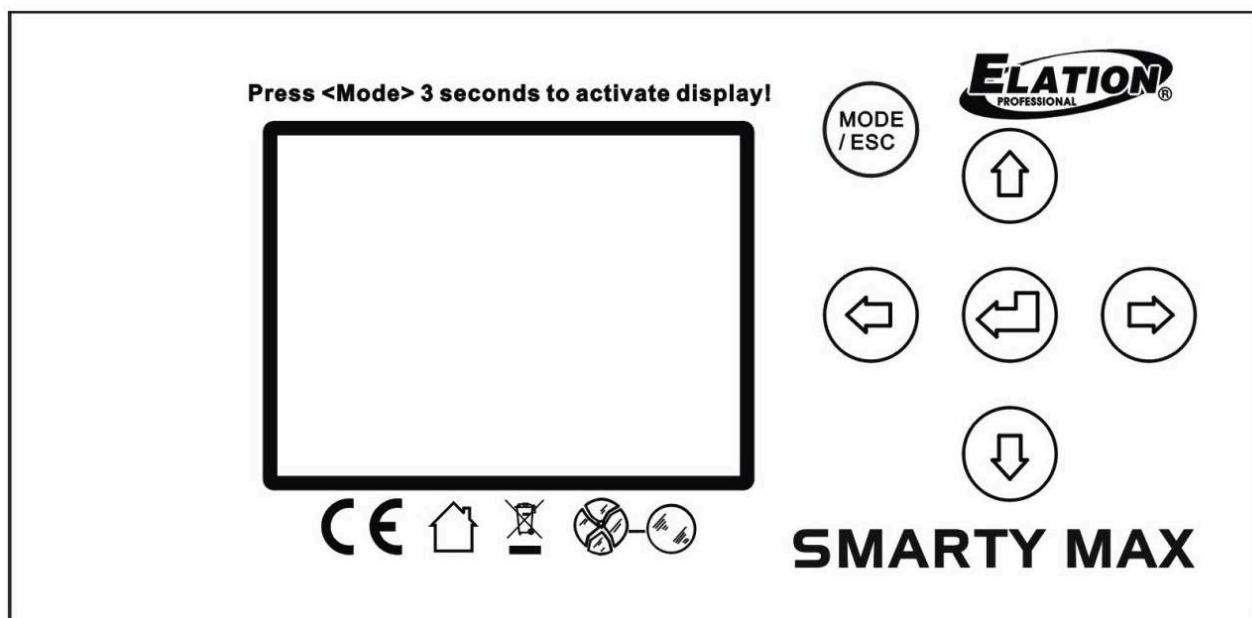

ELATION SMARTY MAX SYSTEM MENU

Features are subject to change without notice. *Rotation direction (Clockwise or Counterclockwise) of effects depends on orientation of the fixture head and Pan/Tilt settings.

MAIN MENU	SUB MENU	OPTIONS / VALUES (Default Settings in BOLD)		DESCRIPTION	
FUNCTION	Set Dmx Address	A001~AXXX		DMX Address Setting	
	Dmx Value	PAN.....		DMX Value Display	
	Secondary Mode	Secondary1, Secondary2, Secondary3		Secondary Setting	
	Auto Program	Primary / Alone		Auto Program	
INFORMATION	Time Information	Current Time	xxxx(Hours)	Fixture Run Time From Power ON	
		Total Run Time	xxxx (Hours)	Fixture Total Run Time	
		Last Run Time	xxxx (Hours)	Fixture Last Run Time	
		Lamp Time Info	Total Time xxxx (Hours)	Total Lamp Time Usage	
			Active Time xxxx (Hours)	Active Lamp Time Usage	
			Idle Time xxxx (Hours)	Idle Lamp Time	
			Lamp Life (% Percent)	Lamp Life	
		LastRun Password	Password = 038	(PSWD Required)	
	Clear Last Run	ON / OFF	Clear Fixture Last Run Time		
	LampTimePassword	Password = 038	(PSWD Required)		
	Clear Lamp Time	ON / OFF	Clear Lamp Run Time		
	Temperature Info	Head Temperature	xxx C° / F°	Temperature in Fixture Head	
		Base Temperature	xxx C° / F°	Temperature in Fixture Base	
	Ethernet IP	xxx . xxx . xxx . xxx	xxx . xxx . xxx . xxx	Displays Fixture Ethernet Address	
	Fan Info	1U_FAN1:xxxx RPM, ...		Speeds of Head/Base Fans	
	Software Version	Vx.x		Software Version	
Error Info	Error Record 1 ~ Error Record 10		Fixture Last 10 Error Codes		
LAMP CONTROL	Lamp On/Off	ON/OFF		Lamp ON/OFF	
	Automatic On	ON/OFF		Lamp ON/OFF when Power ON	
	Lamp On via DMX	ON/OFF		Lamp ON via DMX	
	Lamp Off via DMX	ON/OFF		Lamp OFF via DMX	
	Lamp Power Mode	480W, 470W , 370W		Lamp Power Mode	
PERSONALITY	Status Settings	Address via DMX	ON/OFF	Address Via DMX	
		No DMX Status	Close / Hold / Auto/ SunProt	Fixture State When NO DMX Signal	
		Pan Reverse	ON/OFF	Pan Reverse Movement	
		Tilt Reverse	ON/OFF	Tilt Reverse Movement	
		Pan Degree	630/ 540	Pan Degree Select	
		Feedback	ON/OFF	Movement Feedback	
		Movement Speed	Normal , Slow	Set Movement Speed	
		CMY Speed	Fast / Normal	Select CMY Speed	
		P/T Brake Mode	Smooth , Fast	Set Pan / Tilt Brake Mode	
		Hibernation	OFF, 01M~99M, 15M	Standby Mode	
	Service Setting	Password	Password= 050	Service Password	
		Clear Err. Info	ON/OFF	Clear Error Info (PSWD Required)	
		DFLT Pow. LampOn	ON/OFF	Set Lamp Default Power State	
		DFLT Pow. Efly On	ON/OFF	Set E-FLY Default Power State (E-FLY Optional)	
	Display Setting	USB Update	YES/ NO	Service Port - Software Updates	
		Shutoff Time	02~60m 05m	Display Shut Off Time	
		Display Reverse	ON/OFF/AUTO	Display Reverse 180°	
	PERSONALITY	Key Lock	ON/OFF	Key Lock	
		Temperature C/F	Celsius/Fahrenheit		Temperature Switch Between C° / F°
		Initial Status	PAN =XXX ...		Initial Effect Position
		Select Signal	E-FLY Off, DMX & E-FLY , E-FLY & Out, Art-Net, sACN		Activate Signal Protocol (E-FLY Optional)
		Ethernet IP	XXX . XXX . XXX . XXX		Ethernet IP
		Ether Mask IP	XXX . XXX . XXX . XXX		Ethernet Mask IP
		Set Universe	000 - 32767		Set Art-Net Universe
		Set E-FLY Chn	00 - 14		Set E-FLY Channel (E-FLY Optional)
		Dimmer Curve	Linear , Square, InverseSquare, S-Curve		Set Dimmer Curve Mode
		Reset Default	ON/OFF	Password = 011	Restore Factory Settings (PSWD Required)

ELATION SMARTY MAX SYSTEM MENU

Features subject to change without notice. *Rotation direction (Clockwise or Counterclockwise) of effects depends on orientation of the fixture head and Pan/Tilt settings.

MAIN MENU	SUB MENU	OPTIONS / VALUES (Default Settings in BOLD)	DESCRIPTION	
Reset Function	Reset All		Reset All Motors	
	Reset Pan&Tilt		Reset Pan/Tilt	
	Reset Colors		Reset Color Wheel	
	Reset Gobos		Reset Gobos	
	Reset Shutter		Reset Shutter	
	Reset Others		Reset Other Motors	
Effect Adjust	Test Channel	PAN	Test function	
	Manual Control	PAN =XXX,	Fine Adjustments	
	Calibration	Calibration Password PAN = XXX, ...	Password 050 (PSWD Required)	
User Mode Set	User Mode	Standard Mode	DMX Channel Modes	
		Extended Mode		
Edit Program	Select Program	Auto Pro Part1 = Program 1~10 (Program 1)	Select Programs To Be Run	
		Auto Pro Part2 = Program 1~10 (Program 2)		
		Auto Pro Part3 = Program 1~10 (Program 3)		
	Edit Program	Program 1	Program Test	Testing Program
		:	Step 01=SCxxx	Program In Loop
		Program 10	Step 64=SCxxx	Save and Exit
	Edit Scenes	Edit Scene 001 ~ Edit Scene 250	Pan,Tilt,.....	Save and Automatically Return
			--Fade Time-- --Scene Time--	Manual Scenes Edit
Input By Out			Stores Scenes via Ext DMX Console	
Rec. Controller	XX~XX		Automatic Scenes Recorder	



**ALTHOUGH E-FLY SETTINGS MAY APPEAR IN THE SYSTEM MENU, THIS FEATURE IS NOT ACTIVATED. E-FLY WIRELESS DMX IS AN OPTIONAL FEATURE WHICH MUST BE ACTIVATED IN THE SERVICE MENU.
PLEASE CONTACT ELATION SERVICE FOR FURTHER DETAILS.**

SYSTEM MENU

PERSONALITY - Status Settings - Address Via DMX

When ON, define the desired DMX address via an external controller.

NOTE: This process assumes the fixture DMX address is set to 001. If fixture DMX address is not at 001, you must adjust the channel numbers accordingly in order for this feature to work.

For example: if your fixture address is 010, then Channel 1 becomes Channel 10, Channel 2 becomes Channel 11, and Channel 3 becomes Channel 12.

1. Connect the fixture to the external controller and power ON.
2. Set the DMX value of **Channel 1** on the controller to **(7)**.
3. Set the DMX value of **Channel 2** on the controller to **(7)** or **(8)**.
When set to **(7)**, the DMX address can be set between **(1)** and **(255)**.
When set to **(8)**, the DMX address can be set between **(256)** and **(511)**.
4. Using **Channel 3** on the controller set the desired DMX address of the fixture.
Example 1: If the desired DMX address is **57**, set **Channel 1** to a value of **(7)**, set **Channel 2** to a value of **(7)**, and then set **Channel 3** to a value of **(57)**.
Example 2: If the desired DMX address is **420**, set **Channel 1** to a value of **(7)**, set **Channel 2** to a value of **(8)**, and then set **Channel 3** to a value of **(164)**. ($256+164=420$)
5. After setting **Channel 3** to the desired DMX address value, wait for approximately 20 seconds (some fixtures may require a longer time) for the fixture to complete the address reset function.

PERSONALITY – Service Setting - Password (050)

The Service Password MUST be entered in order to access the service menus.

PERSONALITY – Service Setting – USB Update

To update the fixture software via the **UPDATE/SERVICE PORT**, follow steps below.



ONLY QUALIFIED TECHNICIANS SHOULD PERFORM THIS FUNCTION!
NOTE ALL MENU SETTINGS BEFORE UPDATING SOFTWARE!
FIXTURE SOFTWARE CAN NOT BE DOWNGRADED!
DOWNLOAD FIXTURE SOFTWARE TO PC ONLY! (NO MAC SUPPORT)
PLEASE CONTACT ELATION SERVICE FOR FURTHER INFORMATION.

1. Copy fixture software update file from a PC computer to a compatible USB flash drive.
Make sure only the fixture software update file is stored on the USB flash drive.
2. Disconnect DMX, Art-Net, and E-FLY connections and power the fixture ON.
3. Insert USB flash drive into the **UPDATE/SERVICE PORT** on the rear connection panel.
4. Navigate to the **Personality** main menu **Service Setting / USB Update** sub menu.
5. Select the software file name on the menu display and press **ENTER**.
6. Select **YES** to begin update process and **Updating...%** will show on the menu display.
7. After file is uploaded, the fixture will check the software which will take some time.
The fixture will perform a reset process when the software update process is complete.
8. Remove the USB flash drive and make necessary system menu setting adjustments.

SYSTEM MENU

PERSONALITY - Display Setting – Key Lock

When ON, Control Panel buttons lock automatically after exiting main menu for 15 seconds. To unlock, keep **MODE/ESC** button pressed for 3 seconds.

PERSONALITY - Reset Default



ONLY QUALIFIED TECHNICIANS SHOULD PERFORM THIS FUNCTION!

This function restores all fixture settings to the factory default settings. The password is **011** and must be entered each time a reset is performed.

EFFECT ADJUST – Test Channel

Auto test each individual channel function independently from the DMX control board.

EFFECT ADJUST – Manual Control

Select and manually test and fine adjust each individual channel function

Independently from DMX control board. This function will center PAN and TILT motors and set dimmer to 100%. PAN and TILT functions will still operate if the fixture needs to be positioned to a flat clear surface. With the individual functions, you can focus the light on a flat surface (wall) and perform fine adjustments.

EFFECT ADJUST – Calibration



ONLY QUALIFIED TECHNICIANS SHOULD PERFORM THIS FUNCTION!

This function allows small adjustments to be made to the Pan, Tilt, and Zoom movements to compensate for wear or in the event a sensor has been knocked slightly out of place. Because improper use of this function can result in undesired operation this function has been password protected. The password is **050** and must be entered each time the calibration menu function is entered. Because calibration is an extremely delicate procedure, instructions on performing this action are left out of this manual. For a first-time calibrator, please contact our customer support team for step-by-step instructions.

SYSTEM MENU

EDIT PROGRAM – Rec. Controller

The fixture features an integrated DMX-recorder by which you can transmit the programmed scenes from your DMX-controller to the moving head. Adjust the desired scene numbers via the encoder (from – to). When you call up the scenes at your controller, they will automatically be transmitted to the moving head.

EDIT PROGRAM – Record Controller – Working with Built-In Programs

A Primary unit can send up to 3 different data groups to the Secondary units, i.e. a Primary unit can start 3 different Secondary units, which run 3 different programs. The Primary unit sends the 3 program parts in a continuous loop.

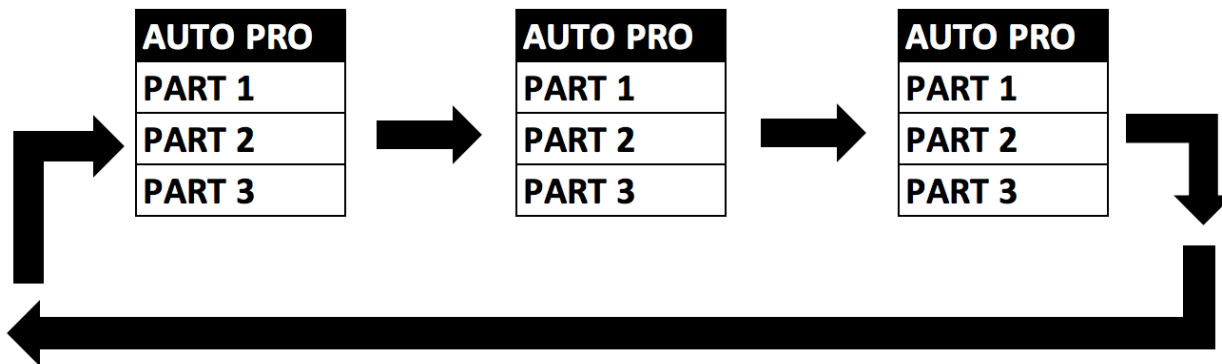

The Secondary unit receives data from the Primary unit according to the group which the Secondary unit was assigned to. If e.g. a Secondary unit is set to “**Secondary 1**” in the menu “**Set to Secondary**”, the Primary unit sends “**Auto Program Part 1**” to the Secondary unit.

If set to “**Secondary 2**”, the Secondary unit receives “**Auto Program Part 2**”.

SYSTEM MENU

EDIT PROGRAM – Record Controller – Working with Built-In Program [continued]

To start an Auto Program, proceed as follows:

1. Secondary Setting

Select “**Function Mode**”.

Press **ENTER** to confirm.

Select “**Set to Secondary**”.

Press **ENTER** to confirm.

Select “**Secondary 1**”, “**Secondary 2**” or “**Secondary 3**”.

Press **ENTER** to confirm.

Press **MODE/ESC** in order to return to the main menu.

2. Automatic Program Run

Select “**Function Mode**”.

Press **ENTER** to confirm.

Select “**Auto Program**”.

Press **ENTER** to confirm.

Select “**Primary**” or “**Alone**”.

Press **ENTER** to confirm.

Press **MODE/ESC** in order to return to the main menu.

3. Program Selection for Auto Pro Part

Select “**Edit Program**”.

Press **ENTER** to confirm.

Select “**Select Programs**”.

Press **ENTER** to confirm.

Select “**Auto Pro Part 1**”, “**Auto Pro Part 2**” or “**Auto Pro Part 3**” and select which Secondary program is to be sent. Selection “**Part 1**” means, that the Secondary unit runs the same program as the primary units.

Press **ENTER** to confirm.

Press **MODE/ESC** in order to return to the main menu.

4. Program Selection for Edit Program

Select “**Edit Program**”.

Press **ENTER** to confirm.

Select “**Edit Program**”.

Press **ENTER** to confirm.

Select the desired program to edit specific scenes into a specific program.

Press **ENTER** to confirm.

Press **MODE/ESC** in order to return to the main menu.

SYSTEM MENU

EDIT PROGRAM – Record Controller – Working with Built-In Program [continued]

5. Automatic Scene Recording

Select “**Edit Program**”.

Press **ENTER** to confirm.

Select “**Edit Scenes**”.

Select desired scene numbers. A maximum of 250 scenes can be programmed.

Press **ENTER** to confirm.

Press **MODE/ESC** in order to return to the main menu.

Example:

Program 2 includes scenes: 10, 11, 12, & 13

Program 4 includes scenes: 8, 9, & 10

Program 6 includes scenes: 12, 13, 14, & 15

Auto Pro Part 1 is Program 2

Auto Pro Part 2 is Program 3

Auto Pro Part 3 is Program 6

The 3 Secondary groups run the Auto Program in certain time segments. (See chart below)

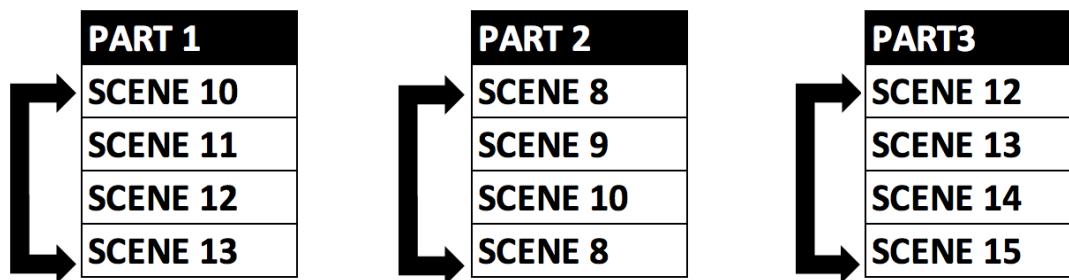

DIMMER MODE

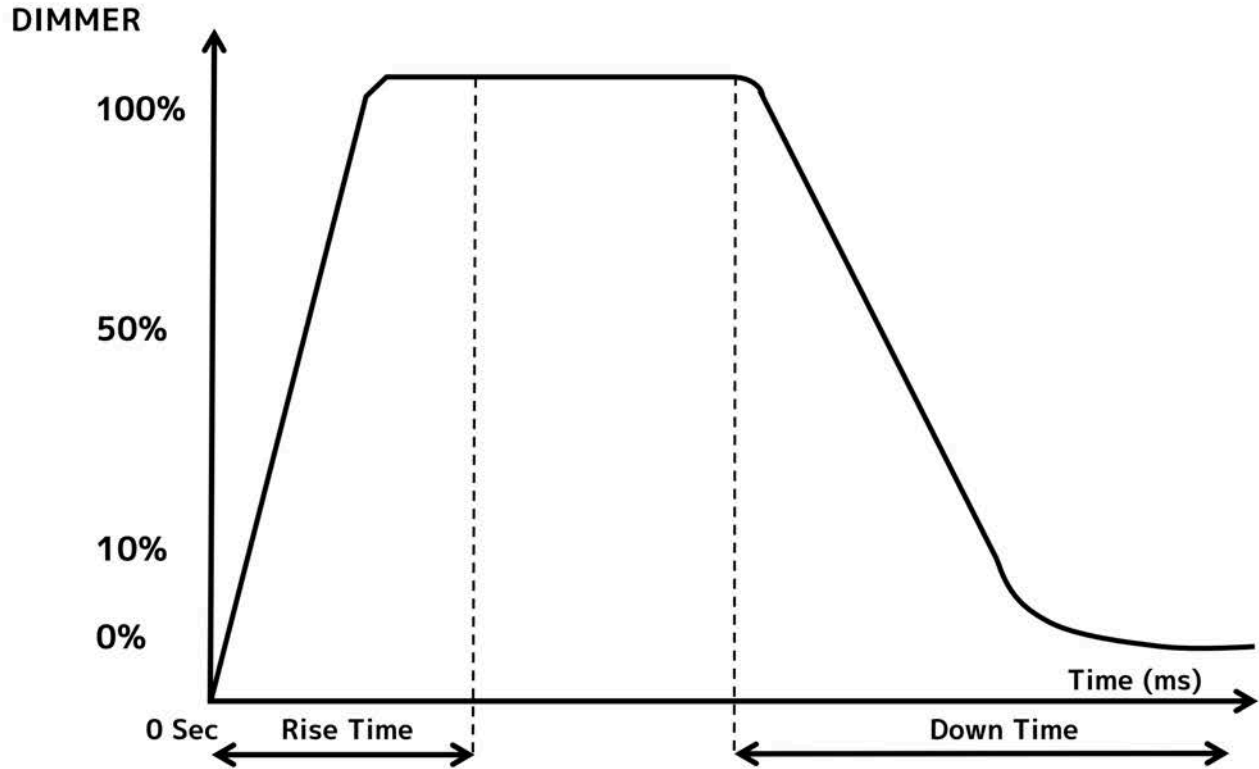

Dimming Curve Ramp Effect	0 sec Fade Time		1 sec Fade Time	
	Rise Time (ms)	Down Time (ms)	Rise Time (ms)	Down Time (ms)
Standard (default)	0	0	0	0
Stage	780	1100	1540	1660
TV	1180	1520	1860	1940
Architectural	1380	1730	2040	2120
Theatre	1580	1940	2230	2280
Stage 2	0	1100	0	1660

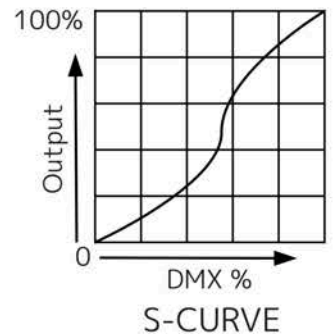
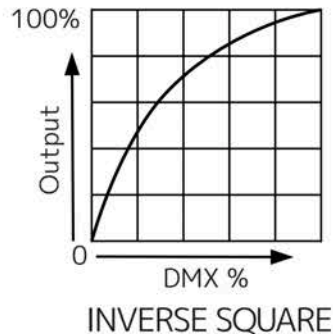
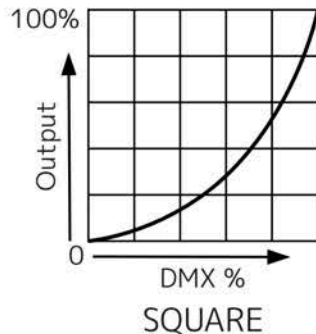
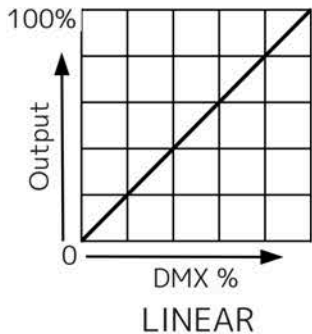

DMX TRAITS

Features subject to change without notice.					
*Rotation direction (Clockwise/Counterclockwise) and control of effects depends on head orientation and Pan/Tilt settings.					
Standard	Extended	Value	Function	Default	Snap
1	1	0-255	PAN Movement 8bit: Pan Movement		
2	2	0-255	Pan Fine 16bit: Fine control of Pan movement		
3	3	0-255	TILT Movement 8bit: Tilt Movement		
4	4	0-255	Tilt Fine 16bit: Fine control of Tilt Movement		
5	5	0-255	Cyan: (0-100% Cyan)		
	6	0-255	Cyan Fine: Cyan Fine		
6	7	0-255	Magenta: (0-100% Magenta)		
	8	0-255	Magenta Fine: Magenta Fine		
7	9	0-255	Yellow: (0-100% Yellow)		
	10	0-255	Yellow Fine: Yellow Fine		
8	11	0-255	CTO: (0-100% CTO)		
	12	0-255	CTO Fine: CTO Fine		
9	13		Color Wheel:		
		0-10	Open		
		11-19	Red		
		20-28	Green		
		29-37	Yellow		
		38-46	Purple		
		47-55	Light Blue		
		56-64	Orange		
		65-73	Magenta		
		74-82	AQUA		
		83-91	Pink		
		92-100	UV		
		101-109	CTB		
		110-118	CTO		
		119-127	Deep Blue		
			Color Scroll		
		128-180	Clockwise, fast→slow		
		181	Stop		
		182-234	Counter-clockwise, slow→ fast		
			Random Slots		
235-239	Fast				
240-244	Medium				
245-249	Slow				
250-255	Open				
	14	0-255	Color Wheel Fine: Fine Control of Color Wheel position		

Standard	Extended	Value	Function	Default	Snap
10	15		Rotating Gobo		
		0-10	Beam open		
		11-21	Spot open		
		22-31	Rot. gobo 1		
		32-41	Rot. gobo 2		
		42-51	Rot. gobo 3		
		52-61	Rot. gobo 4		
		62-71	Rot. gobo 5		
		72-81	Rot. gobo 6		
		82-91	Rot. gobo 7		
		92-101	Rot. gobo 8		
		102-112	Rot. gobo 1 shake		
		113-123	Rot. gobo 2 shake		
		124-134	Rot. gobo 3 shake		
		135-145	Rot. gobo 4 shake		
		146-156	Rot. gobo 5 shake		
		157-167	Rot. gobo 6 shake		
		168-178	Rot. gobo 7 shake		
		179-189	Rot. gobo 8 shake		
		190-221	Scroll CW fast to slow		
222-223	Stop				
224-255	Scroll CCW slow to fast				
11	16		Rotating Gobo Index, Rotation		
		0-127	Gobo indexing		
		128-189	Clockwise gobo scroll from fast to slow		
		190-193	No rotation		
	17	0-255	Rotating gobo fine indexing: Fine indexing		

Standard	Extended	Value	Function	Default	Snap
12	18		Fixed gobos1		
		0-7	Open		
		8-14	Gobo 1		
		15-21	Gobo 2		
		22-28	Gobo 3		
		29-35	Gobo 4		
		36-42	Gobo 5		
		43-49	Gobo 6		
		50-56	Gobo 7		
		57-63	Gobo 8		
		64-70	Gobo 9		
		71-77	Gobo 10		
		78-84	Gobo 11		
		85-91	Gobo 12		
		92-98	Gobo 13		
		99-105	Gobo 14		
		106-111	Gobo 1 shake slow to fast		
		112-117	Gobo 2 shake slow to fast		
		118-123	Gobo 3 shake slow to fast		
		124-129	Gobo 4 shake slow to fast		
		130-135	Gobo 5 shake slow to fast		
		136-141	Gobo 6 shake slow to fast		
		142-147	Gobo 7 shake slow to fast		
		148-153	Gobo 8 shake slow to fast		
		154-159	Gobo 9 shake slow to fast		
		160-165	Gobo 10 shake slow to fast		
		166-171	Gobo 11 shake slow to fast		
		172-177	Gobo 12 shake slow to fast		
		178-183	Gobo 13 shake slow to fast		
		184-189	Gobo 14 shake slow to fast		
190-221	Scroll CW fast to slow				
222-223	Stop				
224-255	Scroll CCW slow to fast				

Standard	Extended	Value	Function	Default	Snap
	19	0-255	Fixed gobo indexing Fine 1: Fine indexing		
13	20		Rotating Prism,Prism/Gobo macros:		
		0-63	Open		
		64-95	Prism 8x		
		96-127	Prism 6 Linear		
		128-135	Macro1		
		136-143	Macro2		
		144-151	Macro3		
		152-159	Macro4		
		160-167	Macro5		
		168-175	Macro6		
		176-183	Macro7		
		184-191	Macro8		
		192-199	Macro9		
		200-207	Macro10		
		208-215	Macro11		
		216-223	Macro12		
		224-231	Macro13		
232-239	Macro14				
240-247	Macro15				
248-255	Macro16				
14	21		Rotating prism index,rotating gobo rotation:		
		0-127	Prism indexing		
		128-189	Clockwise prism rotation from fast to slow		
		190-193	No rotation		
		194-255	Counter-clockwise prism rotation from slow to fast		
	22	0-255	Rotating prism indexing Fine: Fine indexing		
15	23		Rotating Prism 2		
		0-63	Open		
		64-95	Prism 16x		
		96-127	Prism 4 Linear		
		128-255	Reserved		
16	24		Rotating prism 2 index,rotating gobo rotation:		
		0-127	Prism indexing		
		128-189	Clockwise prism rotation from fast to slow		
		190-193	No rotation		
		194-255	Counter-clockwise prism rotation from slow to fast		
	25	0-255	Rotating prism 2 indexing Fine: Fine indexing		

Standard	Extended	Value	Function	Default	Snap
17	26	0-255	Focus: Focus edge adjustment		
	27	0-255	Focus Fine: Focus adjustment Fine		
18	28	0-255	Zoom: Zoom adjustment from small to big		
	29	0-255	Zoom Fine: Zoom adjustment Fine		
	30		Auto Focus:		
		0-50	Auto Focus Off		
		51-150	15m		
		151-255	20m		
	31	0-255	AutoFocus Fine: Continuous adjustment Fine		
19	32		Shutter, strobe:		
		0-31	Shutter closed		
		32-63	No function (shutter open)		
		64-95	Strobe effect slow to fast		
		96-127	No function (shutter open)		
		128-159	Pulse-effect in sequences		
		160-191	No function (shutter open)		
		192-223	Random strobe effect slow to fast		
		224-255	No function (shutter open)		
20	33	0-255	Dimmer: Intensity 0 to 100%		
21	34	0-255	Dimmer Fine: Dimmer Fine		
22	35		Iris:		
		0-191	Max. diameter to Min.diameter		
		192-223	Pulse closing fast to slow		
		224-255	Pulse opening slow to fast		
	36	0-255	Iris Fine: Iris Fine		
23	37	0-255	Frost 1: Min to Max		
24	38	0-255	Frost 2: Min to Max		
25	39		Animation wheel:		
		0	Open		
		1-127	Track 1 min to max		
		128-255	Track 2 min to max		
26	40		Animation index, animation rotation:		
		0-127	Animation indexing		
		128-189	Clockwise animation rotation from fast to slow		
		190-193	No rotation		
		194-255	Counter-clockwise animation rotation from slow to fast		
	41	0-255	Speed of CMY & Colour macro Speed: Speed Max -> Min		

Standard	Extended	Value	Function	Default	Snap
			Color macros - CMY and colour wheel:		
		0-31	OFF		
		32-39	Macro1		
		40-47	Macro2		
		48-55	Macro3		
		56-63	Macro4		
		64-71	Macro5		
		72-79	Macro6		
		80-87	Macro7		
		88-95	Macro8		
		96-103	Macro9		
		104-111	Macro10		
		112-119	Macro11		
		120-127	Macro12		
	42	128-135	Macro13		
		136-143	Macro14		
		144-151	Macro15		
		152-159	Macro16		
		160-167	Macro17		
		168-175	Macro18		
		176-183	Macro19		
		184-191	Macro20		
		192-199	Macro21		
		200-207	Macro22		
		208-215	Macro23		
		216-223	Macro24		
		224-231	Macro25		
		232-239	Macro26		
		240-247	Macro27		
		248-255	Random CMY		
			Pan / Tilt Speed:		
		0-225	Max to min speed		
	43	226-235	Blackout by movement		
		236-245	Blackout by all wheel changing		
		246-255	No function		

Standard	Extended	Value	Function	Default	Snap
27	44		Control:		
		0-19	color change normal		
		20-29	color change to any position		
		30-39	Color & gobo change to any position		
		40-49	Lamp on		
		50-59	Lamp off		
		60-66	Lamp power 370W		
		67-73	Lamp power 470W		
		74-79	Lamp power 480W		
		80-84	All motor reset		
		85-87	Pan Tilt motor reset		
		88-90	Color motor reset		
		91-93	Gobo motor reset		
		94-96	Shutter & Dimmer motor reset		
		97-99	Other motor reset		
		100-168	Idle		
		169-170	CMY Fast		
		171-172	CMY Normal (default)		
		173-174	Hibernation Off		
		175-176	Hibernation		
		177-178	Home Position Before Power Off		
		179-180	Home Position Off		
		181-190	Pan Tilt Smooth (default)		
		191-200	Pan Tilt Fast		
		201-210	Dimmer Curve Linear (default)		
		211-220	Dimmer Curve Square		
		221-230	Dimmer Curve Inverse Square		
		231-240	Dimmer Curve S-Curve		
		241	Internal program 1		
		242	Internal program 2		
		243	Internal program 3		
		244	Internal program 4		
		245	Internal program 5		
		246	Internal program 6		
247	Internal program 7				
248-249	Idle				
250-251	Display off				
252-253	Display on				
254-255	Idle				

REMOTE DEVICE MANAGEMENT (RDM)

NOTE: For RDM to work properly, RDM enabled equipment must be used throughout the entire system, including DMX data splitters and wireless systems.

Remote Device Management (RDM) is a protocol that sits on top of the DMX512 data standard for lighting, allowing the DMX systems of the device to be managed, modified, and monitored remotely (hence, remote device management). This protocol is ideal for fixtures installed in locations that are not easily accessible.

With RDM, the DMX512 system becomes bi-directional, allowing a compatible RDM enabled controller to send out a signal to devices on the wire, as well as allowing the fixture to respond (known as a GET command). The controller can then use it's SET command to modify settings that would typically have to be changed or viewed directly via the unit's display screen, including the DMX Address, DMX Channel Mode, and Temperature Sensors.

FIXTURE RDM INFORMATION:

RDM Code	DEVICE ID	Device Model ID Hexadecimal	Personality ID
0X626	OPEN	1574	OPEN

Please be aware that not all RDM devices support all RDM features, and therefore it is important to check beforehand to ensure that the equipment that you are considering includes all the features that you require.

The following parameters are accessible in RDM on this device:

Sensor Definition
Sensor Value
Device Model Description
Manufacturer Label
Device Label
DMX Personality
DMX Personality Description
Device Hours
Lamp Hours
Lamp State
Pan Invert
Tilt Invert
Display Invert

SOFTWARE UPDATES

E-LOADER III



**ONLY QUALIFIED TECHNICIANS SHOULD PERFORM THIS FUNCTION!
NOTE ALL MENU SETTINGS BEFORE UPDATING SOFTWARE!
FIXTURE SOFTWARE CAN NOT BE DOWNGRADED!
DOWNLOAD FIXTURE SOFTWARE TO PC ONLY! (NO MAC SUPPORT)
PLEASE CONTACT ELATION SERVICE FOR FURTHER INFORMATION.**

An Elation E-Loader III can be used to update the fixture to the latest software. Please visit the E-Loader III product page at the Elation web site and download the product manual for step by step instructions.

<https://www.elationlighting.com/e-loader-iii-software-uploader>

To order the E-Loader III uploader and the updated software for your fixture, please contact Elation support for details.

UPDATE/SERVICE PORT

1. Copy fixture software update file from a PC computer to a compatible USB flash drive. Make sure only the fixture software update file is stored on the USB flash drive.
2. Disconnect DMX, Art-Net, and E-FLY connections and power the fixture ON.
3. Insert USB flash drive into the UPDATE/SERVICE PORT on the rear connection panel.
4. Navigate to the Personality > Service Setting > USB Update sub menu.
5. Select the software file name on the menu display and press ENTER.
6. Select YES to begin update process and Updating...% will show on the menu display.
7. After file is uploaded, the fixture will check the software which will take some time.
8. The fixture will perform a reset process when the software update process is complete.
9. Remove the USB flash drive and make necessary system menu setting adjustments.

ERROR CODES

When power is applied, the unit will automatically enter a “**Reset/Test**” mode. This mode brings all the internal motors to a home position. If there is an internal problem with one or more of the motors an error code will flash in the display in the form of “**XXer**” where XX will represent a function number. For example, when the display shows “**0Er**” it means there is some type of error with the Pan motor. If there are multiple errors during the start-up process, they will all flash in the display. For example: if the fixtures have errors on **Channel 1, 2, and 5** all at the same time, you will see the error message “**01Er**”, “**02Er**”, and “**05Er**” flash repeated 5 times.

If an error does occur during the initial start-up procedure the fixture will self-generate a second reset signal and try to realign all the motors and correct the errors. If the error persists after a second attempt a third attempt will be made. If after a third attempt all the errors have not been corrected the fixture will make the following determinations:

3 or More Errors - The fixture cannot function properly with three or more errors therefore the fixture will place itself in a stand-by mode until subsequent repairs can be made.

Less Than 3 Errors - The fixture has less than 3 errors; therefore, most other functions will work properly. The fixture will attempt to operate normally until the errors can be corrected by a technician. The errors in question will remain flashing in the display as a reminder of internal errors.

Error Codes subject to change without notice.	
ERROR CODES	DESCRIPTION
PAN Er	Movement is not located in the default position after the reset. This message will appear after a fixture reset if the magnetic-indexing circuit malfunctions (sensor failed, or magnet is missing) or there is a motor failure (defective motor or a defective motor IC drive on the main PCB). This error may also be displayed if the head/yoke was blocked during a reset function.
TILT Er	
Zoom Er	
Focus Er	
Color Wheel Er	
Cyan Color Er	
Magenta Color Er	
Yellow Color Er	
CTO Color Er	
Rot Gobo Er	
Gobo Rot Er	
Fix Gobo Er	
Animation Er	
AnimationRot Er	
Prism Er	
Prism Rot Er	
Prism 2 Er	
Prism Rot 2 Er	
Frost 1 Er	
Frost 2 Er	
Iris Er	
Flow Er	

SPECIFICATIONS

SOURCE

Philips MSD Platinum 400 Flex 480W Lamp
Variable Lamp Power 370/470/480W
Automated Lamp Hibernation with Instant
Recovery

Up to 4,000 Hour Lamp Life*

*Test lab conditions. May vary depending on several factors including but not limited to:
Environmental Conditions, Power/Voltage, Usage Patterns (On-Off Cycling), Control, and Dimming.

PHOTOMETRIC DATA

21,000+ Lumen Total Fixture Output

1.5° Beam: 1,784,448 LUX (165,781 FC) @5m (16.4ft)

3° Spot: 462,508 LUX (42,968 FC) @5m (16.4ft)

Beam

Zoom Range 2° - 20°

Beam Angle 0.8° - 6.5°

Field Angle 1.8° - 16.2°

Spot

Zoom Range 3° - 30°

Beam Angle 1.7° - 14.8°

Field Angle 3° - 26.5°

Wash

Zoom Range 9° - 35°

Beam Angle 6.8° - 29°

Field Angle 12.8° - 39.4°

EFFECTS

Beam, Spot and Wash Modes

Motorized Zoom

Dual Frost Filter for Light Frost/ Full Wash

4 Prisms on Dual Planes

Iris

CMY Color, Gobo, Prism Macros

Motorized Focus with Auto-Focus Feature

High Speed Shutter and Strobe

Pan Angle: 540°/630°

Tilt Angle: 248°

COLOR

Full CMY Color Mixing System

Variable CTO

Instant 13 Position Color Wheel

GOBOS

2 Gobo Wheels

8 Interchangeable-Rotating / Indexing Glass Gobos

14 Static-Stamped Metal Gobos

Dual Track Animation Wheel

CONTROL / CONNECTIONS

2 DMX Channel Modes (27 / 44 Channels)

(6) Button Touch Panel

Full Color 180° Reversible LCD Menu Display

DMX, RDM, Art-Net and sACN Protocol Support

5pin DMX In/Out

RJ45 Ethernet In/Out

IP65 Locking Power Cable In/Out

With Wired Digital Communication Network

SIZE / WEIGHT

Length: 15.34" (389.8mm)

Width: 17.53" (445.3mm)

Height: 25.27" (642mm)

Center Spacing: 21.0" (533mm)

Weight: 60.0 lbs. (27.2kg)

ELECTRICAL / THERMAL

AC 100-240V 50/60Hz

700 W Max Power Consumption (estimated)

14°F to 113°F (-10°C to 45°C)

BTU/hr (+/- 10%) 2387

APPROVALS / RATINGS

CE | cETLus | IP20

Specifications and documentation subject to change without notice.

DIMENSIONAL DRAWINGS

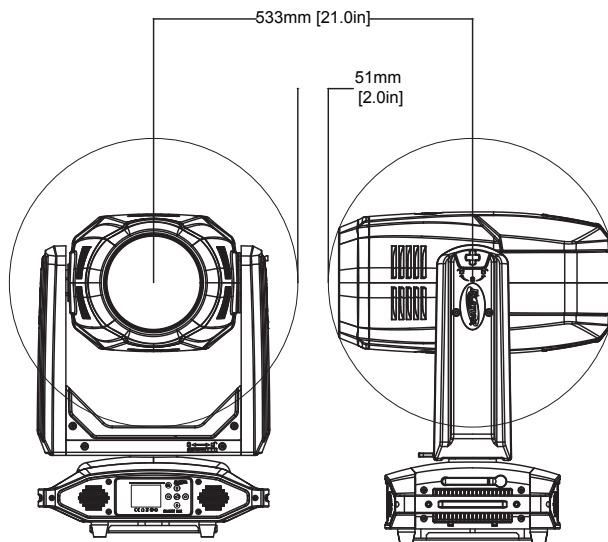
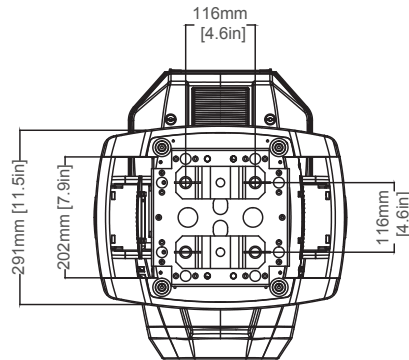
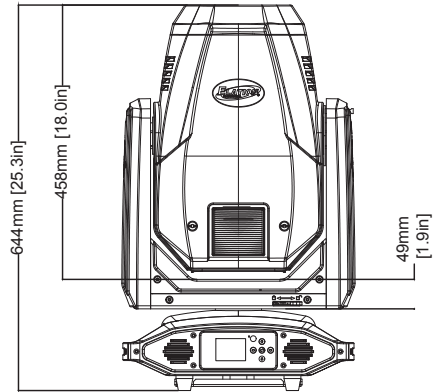
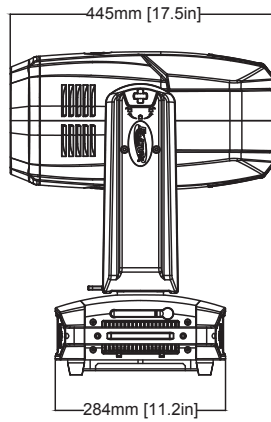
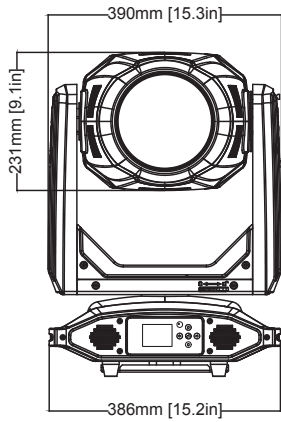

*DRAWINGS NOT TO SCALE

Specifications and improvements in the design of this unit and this manual are subject to change without notice.

DIMENSIONAL DRAWINGS

*DRAWINGS NOT TO SCALE

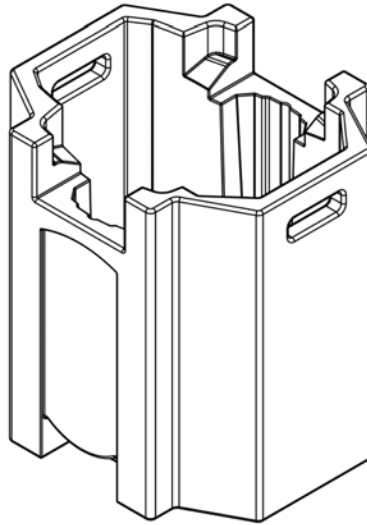
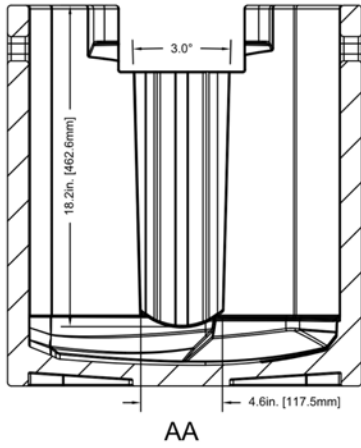
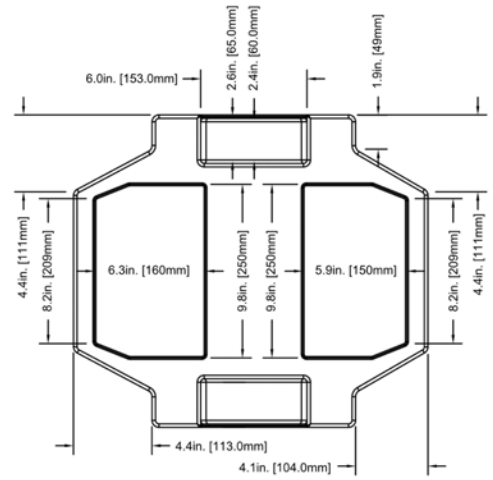
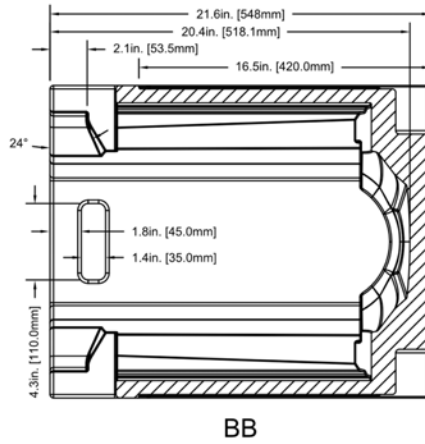
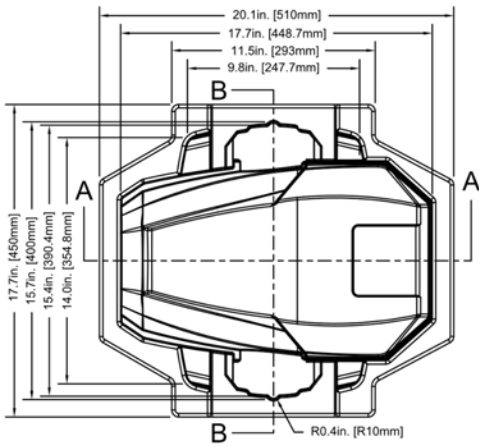

Specifications and improvements in the design of this unit and this manual are subject to change without any prior written notice.

OPTIONAL ACCESSORIES

SKU (US)	SKU (EU)	DESCRIPTION
ESM166	1237000115	Elation Smarty Max
TRIGGER CLAMP	1741000032	Heavy Duty Wrap Around Hook Style Clamp
AC5PDMX5PRO	N/A	5 ft (1.5m) 5pin Pro DMX Cable
NEU088	N/A	3 ft (1m) Power Link Cable
ZB0MSD PLATINUM 400L FLEX	N/A	Philips MSD Platinum 400 Flex Lamp

FCC STATEMENT

This device complies with Part 15 of the FCC Rules. Operation is subject to the following two conditions: (1) this device may not cause harmful interference, and (2) this device must accept any interference received, including interference that may cause undesired operation.

FCC RADIO FREQUENCY INTERFERENCE WARNINGS & INSTRUCTIONS

This product has been tested and found to comply with the limits as per Part 15 of the FCC Rules. These limits are designed to provide reasonable protection against harmful interference in a residential installation. This device uses and can radiate radio frequency energy and, if not installed and used in accordance with the included instructions, may cause harmful interference to radio communications. However, there is no guarantee that interference will not occur in a particular installation. If this device does cause harmful interference to radio or television reception, which can be determined by turning the device off and on, the user is encouraged to try to correct the interference by one or more of the following methods:

- Reorient or relocate the device.
- Increase the separation between the device and the receiver.
- Connect the device to an electrical outlet on a circuit different from which the radio receiver is connected.
- Consult the dealer or an experienced radio/TV technician for help.

Europe Energy Saving Notice

Energy Saving Matters (EuP 2009/125/EC)

Saving electric energy is a key to help protecting the environment. Please turn off all electrical products when they are not in use. To avoid power consumption in idle mode, disconnect all electrical equipment from power when not in use. Thank you

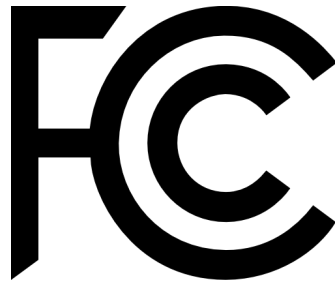

This page intentionally left blank.

