



Opti Tri White Par



User Instructions
V2 Software V1.5



Opti Tri White Par

Introduction

Unpacking: Thank you for purchasing the Opti Tri White Par by Elation Professional®. Every Opti Tri White Par has been thoroughly tested and has been shipped in perfect operating condition. Carefully check the shipping carton for damage that may have occurred during shipping. If the carton appears to be damaged, carefully inspect your fixture for any damage and be sure all accessories necessary to operate the unit has arrived intact. In the case damage has been found or parts are missing, please contact our customer support number for further instructions. Do not return this unit to your dealer without first contacting customer support.

Introduction: The Opti Tri White Par is part of Elation Professionals® continuing pursuit for creating high quality affordable intelligent fixtures. The Opti Tri White Par is a powerful DMX intelligent LED wash. This wash is light weight and compact which makes it a great piece for mobile DJ's and clubs. This unit can be used as a stand alone unit, or in a master/slave configuration. The unit can run in sound active mode, Auto mode, or be controlled via DMX controller.

Customer Support: ©Elation® provides a customer support line, to provide set up help and to answer any question should you encounter problems during your set up or initial operation. You may also visit us on the web at www.elationlighting.com for any comments or suggestions. Service Hours are Monday through Friday 9:00 a.m. to 5:00 p.m. Pacific Standard Time.

Voice: (323) 582-3322
Fax: (323) 582-3108
E-mail: support@elationlighting.com

Warning! To prevent or reduce the risk of electrical shock or fire, do not expose this unit to rain or moisture.

Caution! There are no user serviceable parts inside this unit. Do not attempt any repairs yourself, doing so will void your manufactures warranty. In the unlikely event your unit may require service please contact ©Elation customer support.

PLEASE recycle the shipping carton when ever possible.

Opti Tri White Par

General Instructions

To optimize the performance of this product, please read these operating instructions carefully to familiarize yourself with the basic operations of this unit. These instructions contain important safety information regarding the use and maintenance of this unit. Please keep this manual with the unit, for future reference.

Opti Tri White Par

Features

- Dual Yoke for Floor Mounting
- DMX-512 protocol
- 2 DMX Channel Modes: 4 Channel mode & 7 Channel Mode
- Dimming 0-100%
- 3 and 5 Pin DMX Inputs and Outputs
- Tri White Technology: Cool, Warm, & Amber
- Built-In Microphone for Sound Active Mode
- 13 Preset Color Temperatures (Macros)
- Strobing

Opti Tri White Par

Warranty Registration

The Opti Tri White Par carries a two year limited warranty. Please fill out the enclosed warranty card to validate your purchase. All returned service items whether under warranty or not, must be freight pre-paid and accompany a return authorization (R.A.) number. The R.A. number must be clearly written on the outside of the return package. A brief description of the problem as well as the R.A. number must also be written down on a piece of paper included in the shipping carton. If the unit is under warranty, you must provide a copy of your proof of purchase invoice. You may obtain a R.A. number by contacting our customer support team on our customer support number. All packages returned to the service department not displaying a R.A. number on the outside of the package will be returned to the shipper.

Opti Tri White Par

Safety Precautions

- To reduce the risk of electrical shock or fire, do not expose this unit rain or moisture
- Do not spill water or other liquids into or on to your unit.
- Do not attempt to operate this unit if the power cord has been frayed or broken. Do not attempt to remove or break off the ground prong from the electrical cord. This prong is used to reduce the risk of electrical shock and fire in case of an internal short.
- Disconnect from main power before making any type of connection.
- Do not remove the cover under any conditions. There are no user serviceable parts inside.
- Never operate this unit when it's cover is removed.
- Never plug this unit in to a dimmer pack
- Always be sure to mount this unit in an area that will allow proper ventilation. Allow about 6" (15cm) between this device and a wall.
- Do not attempt to operate this unit, if it becomes damaged.
- This unit is intended for indoor use only, use of this product out doors voids all warranties.
- During long periods of non-use, disconnect the unit's main power.
- Always mount this unit in safe and stable matter.
- Power-supply cords should be routed so that they are not likely to be walked on or pinched by items placed upon or against them, paying particular attention to the point they exit from the unit.
- Cleaning -The fixture should be cleaned only as recommended by the manufacturer. See page 12 for cleaning details.
- Heat -The appliance should be situated away from heat sources such as radiators, heat registers, stoves, or other appliances (including amplifiers) that produce heat.
- The fixture should be serviced by qualified service personnel when:
 - A. The power-supply cord or the plug has been damaged.
 - B. Objects have fallen, or liquid has been spilled into the appliance.
 - C. The appliance has been exposed to rain or water.
 - D. The appliance does not appear to operate normally or exhibits a marked change in performance.

Power Supply: The Elation Opti Tri White Par contains an automatic voltage switch, which will auto sense the voltage when it is plugged into the power source. With this switch there is no need to worry about the correct power voltage, this unit can be plugged in anywhere.

DMX-512: DMX is short for Digital Multiplex. This is a universal protocol used as a form of communication between intelligent fixtures and controllers. A DMX controller sends DMX data instructions from the controller to the fixture. DMX data is sent as serial data that travels from fixture to fixture via the DATA “IN” and DATA “OUT” XLR terminals located on all DMX fixtures (most controllers only have a DATA “OUT” terminal).

DMX Linking: DMX is a language allowing all makes and models of different manufactures to be linked together and operate from a single controller, as long as all fixtures and the controller are DMX compliant. To ensure proper DMX data transmission, when using several DMX fixtures try to use the shortest cable path possible. The order in which fixtures are connected in a DMX line does not influence the DMX addressing. For example; a fixture assigned a DMX address of 1 may be placed anywhere in a DMX line, at the beginning, at the end, or anywhere in the middle. When a fixture is assigned a DMX address of 1, the DMX controller knows to send DATA assigned to address 1 to that unit, no matter where it is located in the DMX chain.

Data Cable (DMX Cable) Requirements (For DMX Operation):

The Opti Tri White Par can be controlled via DMX-512 protocol. The Opti Tri White Par has 2 DMX Channel Modes; 4 Channel mode and 7 Channel mode. Your unit and your DMX controller require a approved DMX-512 110 Ohm Data cable for data input and data output. We recommend Accu-Cable DMX cables. If you are making your own cables, be sure to use standard 110-120 Ohm shielded cable (This cable may be purchased at almost all professional sound and lighting stores). Your cables should be made with a male and female XLR connector on either end of the cable. Also remember that DMX cable must be daisy chained and cannot be split.



Figure 1

Notice: Be sure to follow figures two and three when making your own cables. Do not use the ground lug on the XLR connector. Do not connect the cable’s shield conductor to the ground lug or allow the shield conductor to come in contact with the XLR’s outer casing. Grounding the shield could cause a short circuit and erratic behavior.

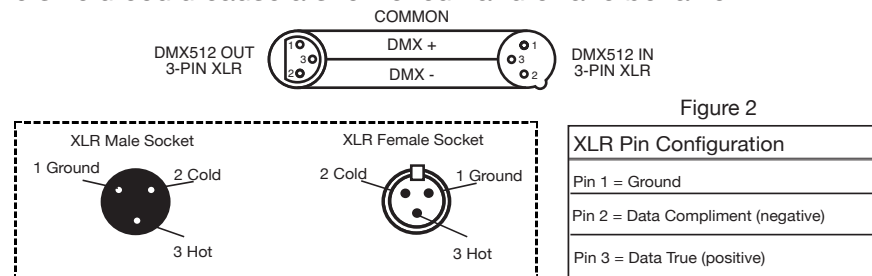

Figure 2

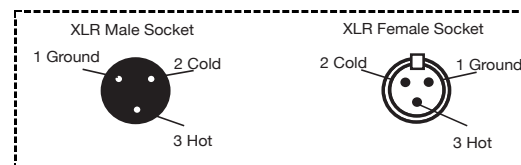

Figure 3

Special Note: Line Termination. When longer runs of cable are used, you may need to use a terminator on the last unit to avoid erratic behavior. A terminator is a 110-120 ohm 1/4 watt resistor which is connected between pins 2 and 3 of a male XLR connector (DATA + and DATA -). This unit is inserted in the female XLR connector of the last unit in your daisy chain to terminate the line. Using a cable terminator (ADJ part number Z-DMX/T) will decrease the possibilities of erratic behavior.



Termination reduces signal errors and avoids signal transmission problems and interference. It is always advisable to connect a DMX terminal, (Resistance 120 Ohm 1/4 W) between PIN 2 (DMX-) and PIN 3 (DMX +) of the last fixture.

Figure 4

5-Pin XLR DMX Connectors. Some manufactures use 5-pin DMX-512 data cables for DATA transmission in place of 3-pin. 5-pin DMX fixtures may be implemented in a 3-pin DMX line. When inserting standard 5-pin data cables in to a 3-pin line a cable adaptor must be used, these adaptors are readily available at most electric stores. The chart below details a proper cable conversion.

3-Pin XLR to 5-Pin XLR Conversion		
Conductor	3-Pin XLR Female (Out)	5-Pin XLR Male (In)
Ground/Shield	Pin 1	Pin 1
Data Compliment (- signal)	Pin 2	Pin 2
Data True (+ signal)	Pin 3	Pin 3
Not Used		Do Not Use
Not Used		Do Not Use

LED Display On/Off:

To set the display light to turn off after 10 seconds, press the MODE button until DispPerm is displayed. Using the Now the display will blackout after 10s. Press any button to turn the display on again. Be advised though that the display will turn off automatically after 10 seconds.

To set the display press the MODE button until DispPerm XX is displayed. "XX" represents either ON or OFF.

DispPerm ON = LCD display light is on at all times.

DispPerm Off = LCD display light shuts off after 10 seconds.

Operating Modes:

- Sound-Active mode - In this mode the unit will react to sound.
- Macro Mode (Preset Color Temperatures) - There are 13 macros (preset color temperatures) macros to choose from.
- DMX control mode - This function will allow you to control each individual fixtures traits with a standard DMX 512 controller such as as the Elation® Show Designer™.

Master-Slave Operation:

This function will allows you to link units together to run in a Master-Slave mode. In Master-Slave operation one unit will act as the controlling unit and the others will react to the controlling units built-in programs. Any unit can act as a Master or as a Slave however, only one unit can be programmed to act as the "Master."

Master-Slave Connections and Settings:

1. Daisy chain your units via the XLR connector on the rear of the unit. Use standard XLR data cables to link your units together. Remember that the Male XLR connector is the input and the Female XLR connector is the output. The first unit in the chain (master) will use the female XLR connector only. The last unit in the chain will use the male XLR connector only.
2. Set the "Master" unit to your desired mode of operation.
3. For the "Slave" unit(s), set the display to DMX address 1.
4. Connect the "Slave" unit or units and they will automatically start to follow the "Master."

Sound Active Mode:

In this mode the Opti Tri White Par will react to sound.

1. Plug the fixture in and press the MODE button until "SoundCtl Color" is displayed. The unit will now react to the beat of the music.

Dimmer Mode:

1. Plug the fixture in and press the MODE button until:
2. When "ColorSet Cool X" is displayed you are in Cool White dimming mode. Press the UP and DOWN buttons to adjust intensity.
3. When "ColorSet Warm X" is displayed you are in Warm White dimming mode. Press the UP and DOWN buttons to adjust intensity.
4. When "ColorSet Amber X" is displayed you are in Amber dimming mode. Press the UP and DOWN buttons to adjust intensity.
5. To return to previous dimming modes you must press the MODE button until that mode is displayed again. Continue to make adjustments until your desired color output/temperature is reached.
6. You can use the chart on page 10 to adjust the dimmer's to certain color temperatures.

Macro Mode (Preset Color Temperature):

In this mode you are able to choose one of 13 macros (preset color temperatures).

1. Plug the fixture in and press the MODE button until "MacroSet Mode X" is displayed. "X" represents the current macro number that is displayed. Each macro is a preset color temperature that is set at the factory. There are 13 color temperatures to choose from.
2. Use the UP and DOWN buttons to find your desired preset macro. See the chart on page 10 for the list of macros and the color temperature it represents.

Strobe Mode:

In this mode you can activate the strobe. The strobe mode will only work in conjunctions with the Dimmer mode.

1. First adjust the Cool White, Warm White, and Amber so that your desired output color is reached.
2. Press the MODE button until "ColStrob Speed XX" is displayed.

Opti Tri White Par

Operating Instructions

“XX” represents the strobe speed.

- Use the UP or DOWN buttons to adjust the strobe speed. “1” is the slowest speed, “20” the fastest speed.

Note. If the Warm White, Cold White, and Amber dimmer modes are all set to “0”, there will be no light output in this mode.

Fade Mode:

In this mode you can activate the auto fade. The fade mode will only work in conjunctions with the Dimmer mode.

- First adjust the Cool White, Warm White, and Amber so that your desired output color is reached.
- Press the MODE button until “ColProgr Speed XX” is displayed. “XX” represents the fade speed.
- Use the UP or DOWN buttons to adjust the fade speed. “1” is the slowest speed, “16” the fastest speed.

Note. If the Warm White, Cold White, and Amber dimmer modes are all set to “0”, there will be no light output in this mode.

DMX Mode:

Operating through a DMX controller gives the user the freedom to create their own programs tailored to their own individual needs. The Opti Tri White Par has two DMX Channel Modes; 4 Channel mode & 7 Channel mode.

- This function will allow you to control each individual fixture’s traits with a standard DMX 512 controller.
- To run your fixture in DMX mode, you must first select which DMX Channel mode you want to use.
- To select 4 Channel mode, press the MODE button until “DMX-4CH DMX X” is displayed. “X” represents the current displayed address. Select your desired DMX address using the UP or DOWN buttons.
- To select 7 Channel mode, press the MODE button until “DMX-7CH DMX X” is displayed. “X” represents the current displayed address. Select your desired DMX address using the UP or DOWN buttons.
- Once you have chose your desired DMX channel mode and set the DMX address plug in the fixture via the XLR connections to any standard DMX controller.
- Please see page 11 for DMX values and traits.

Opti Tri White Par

Macro Preset Temperatures

MODE	Color Temperature(k)	CW	WW	AMBER
1	6 0 0 0	2 5 5	0	0
2	5 7 0 0	2 5 5	2 1	0
3	5 4 0 0	2 5 5	4 6	0
4	5 1 0 0	2 5 5	8 0	0
5	4 8 0 0	2 5 5	1 3 0	0
6	4 5 0 0	2 5 5	2 0 8	0
7	4 2 0 0	2 5 5	2 5 5	4 4
8	3 9 0 0	2 5 5	2 5 5	1 3 4
9	3 6 0 0	2 2 7	2 5 5	2 5 5
10	3 3 0 0	11 4	2 5 5	2 5 5
11	3 0 0 0	9 1	2 5 5	2 5 5
12	2 7 0 0	11	2 5 5	2 5 5
13	2 4 0 0	11	11 3	2 5 5

Opti Tri White Par

Macro Preset Temperatures

CW	495 FC / 5333 LUX	132 FC / 1407 LUX	58 FC / 622 LUX	35 FC / 379 LUX	24 FC / 255 LUX
WW	353 FC / 3797 LUX	85 FC / 913 LUX	39 FC / 416 LUX	23 FC / 248 LUX	15 FC / 166 LUX
A	185 FC / 1991 LUX	50 FC / 543 LUX	23 FC / 246 LUX	14 FC / 147 LUX	9 FC / 99 LUX
ALL	949 FC / 10210 LUX	259 FC / 2789 LUX	117 FC / 1263 LUX	69 FC / 742 LUX	74 FC / 798 LUX

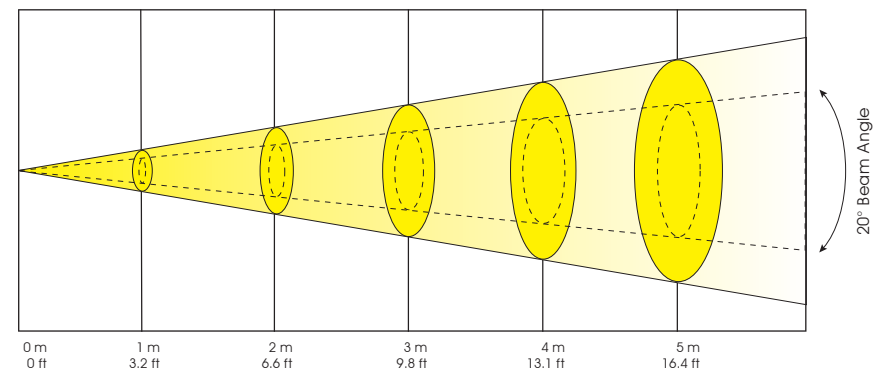

Opti Tri White Par >V1.5 **4 Channel Mode**

Channel	Value	Function
1	0 - 255	COOL WHITE 0% - 100%
2	0 - 255	WARM WHITE 0% - 100%
3	0 - 255	AMBER 0% - 100%
4		DIMMING CURVE MODES
	0-20	STANDARD
	21-40	STAGE
	41-60	TV
	61-80	ARCHITECTURAL
	81-100	THEATER
	101-255	Default to unit setting

Opti Tri White Par >V1.5 **7 Channel Mode**

Channel	Value	Function
1	0 - 255	COOL WHITE 0% - 100%
2	0 - 255	WARM WHITE 0% - 100%
3	0 - 255	AMBER 0% - 100%
4		MACROS (COLOR TEMPERATURES)
	0 - 18	OFF
	19 - 37	MACRO 1 (6000k)
	38 - 56	MACRO 2 (5700k)
	57 - 75	MACRO 3 (5400k)
	76 - 94	MACRO 4 (5100k)
	95 - 113	MACRO 5 (4800k)
	114 - 132	MACRO 6 (4500k)
	133 - 151	MACRO 7 (4200k)
	152 - 170	MACRO 8 (3900k)
	171 - 189	MACRO 9 (3600k)
	190 - 208	MACRO 10 (3300k)
	209 - 227	MACRO 11 (3000k)
	228 - 246	MACRO 12 (2700k)
	247 - 255	MACRO 13 (2400k)
5	0 - 255	STROBING SLOW - FAST
6	0 - 255	MASTER DIMMER 0% - 100%
7		DIMMING CURVE MODES
	0-20	STANDARD
	21-40	STAGE
	41-60	TV
	61-80	ARCHITECTURAL
	81-100	THEATER
	101-255	Default to unit setting

Opti Tri White Par

Fuse Replacement

Disconnect from the main power supply. Insert a standard flat head screw driver in to the fuse holder housing, located on the back of the unit. Turn the screwdriver in counter-clockwise direction to remove the fuse holder. Remove the old fuse and discard it, replace the fuse with the same type. Insert the fuse back into it's housing.

Opti Tri White Par

Cleaning

Due to fog residue, smoke, and dust cleaning the internal and external optical lenses must be carried out periodically to optimize light output.

1. Use normal glass cleaner and a soft cloth to wipe down the outside casing.
2. Clean the external optics with glass cleaner and a soft cloth every 20 days.
3. Always be sure to dry all parts completely before plugging the unit back in.

Cleaning frequency depends on the environment in which the fixture operates (i.e. smoke, fog residue, dust, dew).

Opti Tri White Par

Trouble Shooting

Listed below are a few common problems the user may encounter, with solutions.

Unit not responding to DMX:

1. Check that the DMX cables are connected properly and are wired correctly (pin 3 is "hot"; on some other DMX devices pin 2 may be 'hot'). Also, check that all cables are connected to the right connectors; it does matter which way the inputs and outputs are connected.

Unit does not respond to sound:

1. Quiet or high pitched sounds will not activate the unit.

DIMMING CURVES

The **RampMode** menu allows you to select one of the following preset dimming curves: (0) **Standard**, (1) **Stage**, (2) **TV**, (3) **Architectural**, or (4) **Theatre**.

(See diagram below for more details)

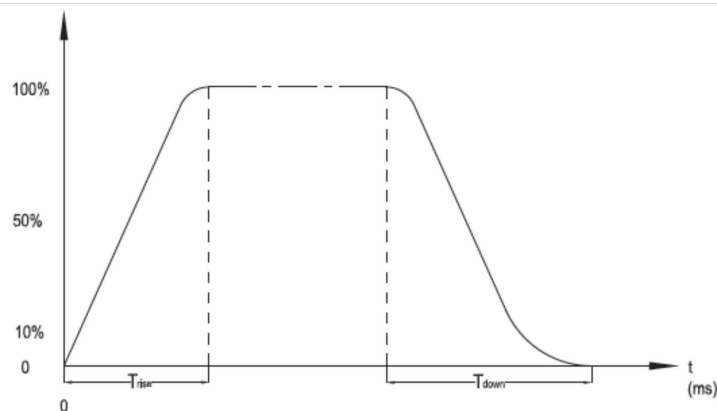

Ramp Effect	OS (Fade Time)		1S (Fade Time)	
	T_{rise} (ms)	T_{down} (ms)	T_{rise} (ms)	T_{down} (ms)
Standard	0	0	0	0
Stage	780	1100	1540	1660
TV	1180	1520	1860	1940
Architectural	1380	1730	2040	2120
Theatre	1580	1940	2230	2280

2-YEAR LIMITED WARRANTY

A. Elation Professionals® hereby warrants, to the original purchaser, Elation Professionals® products to be free of manufacturing defects in material and workmanship for a period of two years (730 days) from the date of purchase. This warranty shall be valid only if the product is purchased within the United States of America, including possessions and territories. It is the owner's responsibility to establish the date and place of purchase by acceptable evidence, at the time service is sought.

B. For warranty service, send the product only to the Elation Professionals® factory. All shipping charges must be pre-paid. If the requested repairs or service (including parts replacement) are within the terms of this warranty, Elation Professionals® will pay return shipping charges only to a designated point within the United States. If the entire instrument is sent, it must be shipped in its original package. No accessories should be shipped with the product. If any accessories are shipped with the product, Elation Professionals® shall have no liability whatsoever for loss of or damage to any such accessories, nor for the safe return thereof.

C. This warranty is void if the serial number has been altered or removed; if the product is modified in any manner which Elation Professionals® concludes, after inspection, affects the reliability of the product; if the product has been repaired or serviced by anyone other than the Elation Professionals® factory unless prior written authorization was issued to purchaser by Elation Professionals®; if the product is damaged because not properly maintained as set forth in the instruction manual.

D. This is not a service contract, and this warranty does not include maintenance, cleaning or periodic check-up. During the period specified above, Elation Professionals® will replace defective parts at its expense, and will absorb all expenses for warranty service and repair labor by reason of defects in material or workmanship. The sole responsibility of Elation Professionals® under this warranty shall be limited to the repair of the product, or replacement thereof, including parts, at the sole discretion of Elation Professionals®. All products covered by this warranty were manufactured after January 1, 1990, and bear identifying marks to that effect.

E. Elation Professionals® reserves the right to make changes in design and/or improvements upon its products without any obligation to include these changes in any products theretofore manufactured.

F. No warranty, whether expressed or implied, is given or made with respect to any accessory supplied with products described above. Except to the extent prohibited by applicable law, all implied warranties made by Elation Professionals® in connection with this product, including warranties of merchantability or fitness, are limited in duration to the warranty period set forth above. And no warranties, whether expressed or implied, including warranties of merchantability or fitness, shall apply to this product after said period has expired. The consumer's and or Dealer's sole remedy shall be such repair or replacement as is expressly provided above; and under no circumstances shall Elation Professionals® be liable for any loss or damage, direct or consequential, arising out of the use of, or inability to use, this product.

G. This warranty is the only written warranty applicable to Elation Professionals® Products and supersedes all prior warranties and written descriptions of warranty terms and conditions heretofore published.

Model: Opti Tri White ParSPECIFICATIONS:

Working Position:	Any safe working position
Voltage:	100V ~ 240V/47~63Hz
LED's:	54 x 3 Watt
Power Consumption:	160W Max
Fuse:	2A
Beam Angle:	20 Degrees
Weight:	10.5lbs./ 4.8Kgs.
Dimensions:	11" (L) x 8.6" (W) x 14" (H)
Colors:	Warm White, Cool White, & Amber
DMX Channels:	2 DMX Modes: 4 Channel Mode & 7 Channel Mode
Warranty:	2 Year (730 days)

Auto Sensing Voltage: *This fixture contains a automatic voltage switch, which will auto sense the voltage when it is plugged into the power source.*

Please Note: Specifications and improvements in the design of this unit and this manual are subject to change without any prior written notice.

©Elation Professionals®
A Division of the AmericanDJ® Group of Companies
World Headquarters:
6122 S. Eastern Ave. Los Angeles, CA 90040 USA
Tel: 323-582-3322 Fax: 323-582-3311
Web: www.elationlighting.com E-mail: info@elationlighting.com

American DJ Europe
Junostraat 2
6468 EW Kerkrade
The Netherlands
service@adjgroup.eu / www.americandj.eu
Tel: +31 45 546 85 00 / Fax: +31 45 546 85 99